

# **NIGHTHAWK**

## **FLIGHT SYSTEMS, INC.**

### **SN4500**

### **Primary Navigation Display**

*with*  
*Reversionary Attitude Mode*  
*And*  
*LNAV Roll Steering*



## **Installation Manual**

Nighthawk Flight Systems, Inc.  
Phone +1-760-727-4900

Website: [www.nighthawkfs.com](http://www.nighthawkfs.com)  
Email: [support@nighthawkfs.com](mailto:support@nighthawkfs.com)

[This page intentionally left blank]

## Table of Contents

<b>1</b>	<b>General Information</b>	<b>1-1</b>
	TSO by SW revision level	1-1
<b>1.1</b>	<b>Introduction</b>	<b>1-1</b>
1.1.1	EXPORT CONTROL NOTICE	1-2
<b>1.2</b>	<b>Equipment Description</b>	<b>1-2</b>
1.2.1	Features	1-2
<b>1.3</b>	<b>Installation Planning</b>	<b>1-3</b>
1.3.1	Installation Planning Cycle	1-3
1.3.2	Post Installation Summary	1-4
<b>1.4</b>	<b>Interface Planning</b>	<b>1-4</b>
1.4.1	Compass System	1-4
1.4.2	Autopilot Switching	1-5
1.4.3	Autopilot Course and Heading Datum	1-5
1.4.4	GPS (FMS) Annunciators	1-6
1.4.5	VLOC Navigation – Internal NAV Converter	1-6
1.4.6	VLOC Navigation – External NAV Converter	1-6
1.4.7	400Hz Differential Resolver	1-7
1.4.8	Marker Beacon	1-7
1.4.9	Bearing Pointers (VOR, ADF, and TACAN)	1-7
1.4.10	ARINC Channels	1-7
1.4.11	DME Interface	1-7
1.4.12	Special Considerations for GARMIN GNS430/530/GTN6XX/7XX	1-7
1.4.13	Special Considerations for GNS XLS Users	1-9
1.4.14	Special Considerations for UPS GXXX	1-9
1.4.15	Display Brightness Control	1-10
1.4.16	Traffic Option	1-10
1.4.17	Data Link Weather Option	1-10
1.4.18	Night Vision Support Option	1-10
1.4.19	TACAN Option	1-11
1.4.20	Reversionary Attitude Option	1-11
1.4.21	Roll Steering Option	1-11
<b>1.5</b>	<b>Disclaimer</b>	<b>1-11</b>
<b>2</b>	<b>Technical Information</b>	<b>2-1</b>
<b>2.1</b>	<b>General</b>	<b>2-1</b>
<b>2.2</b>	<b>Part Numbers</b>	<b>2-1</b>
2.2.1	Installation Kit and Accessories	2-1
2.2.2	Bill of Materials – SN4500 Install Kit	2-1
<b>2.3</b>	<b>Approval Summary</b>	<b>2-2</b>
2.3.1	License Requirements	2-2
2.3.2	Approval Data	2-2
2.3.3	Technical Standard Order Stipulation	2-3
2.3.4	Installation and Operational Approval Procedures	2-3

<b>2.4</b>	<b>Physical, and Electrical Properties</b> .....	<b>2-4</b>
2.4.1	Physical Dimensions.....	2-4
2.4.2	Summary Operational Characteristics.....	2-4
<b>2.5</b>	<b>Connector Summary</b> .....	<b>2-4</b>
2.5.1	Connector P1 .....	2-5
2.5.2	Connector P2 .....	2-9
2.5.3	Connector P3.....	2-12
2.5.4	Configuration Module Connector.....	2-13
2.5.5	Signal Characteristics Table.....	2-14
<b>2.6</b>	<b>ARINC 429</b> .....	<b>2-16</b>
2.6.1	ARINC 429 Serial Data Receivers Interfaces .....	2-16
2.6.2	ARINC 429 Serial Transmitter Interfaces .....	2-18
<b>3</b>	<b>Installation</b> .....	<b>3-1</b>
<b>3.1</b>	<b>General</b> .....	<b>3-1</b>
3.1.1	Unpacking and Inspecting Equipment.....	3-1
<b>3.2</b>	<b>Installation Considerations</b> .....	<b>3-1</b>
3.2.1	General Considerations.....	3-1
3.2.2	Cooling Considerations .....	3-1
3.2.3	Mechanical Installation Considerations .....	3-1
3.2.4	Electrical Installation Considerations .....	3-2
<b>3.3</b>	<b>Signal Details</b> .....	<b>3-4</b>
3.3.1	Connector P-1 Pinout Description.....	3-4
3.3.2	Connector P-2 Pinout Descriptions.....	3-7
3.3.3	Connector P-3 Pinout Descriptions.....	3-10
<b>4</b>	<b>Setup Procedures</b> .....	<b>4-1</b>
<b>4.1</b>	<b>General</b> .....	<b>4-1</b>
<b>4.2</b>	<b>Accessing the Maintenance Menus</b> .....	<b>4-1</b>
<b>4.3</b>	<b>Equipment/Configuration Selection</b> .....	<b>4-1</b>
<b>4.4</b>	<b>Configuration Module</b> .....	<b>4-1</b>
<b>4.5</b>	<b>Configuration Module Status Page</b> .....	<b>4-2</b>
<b>5</b>	<b>Operating Details</b> .....	<b>5-1</b>
<b>6</b>	<b>Instructions For Continued Airworthiness</b> .....	<b>6-1</b>
<b>7</b>	<b>Appendix A: Post-Installation Procedures</b> .....	<b>7-1</b>
7.1.1	Page 1: INDEX.....	7-2
7.1.2	Page 2: SYSTEM.....	7-3
7.1.3	Page 3: COMPASS SYSTEM .....	7-4
	ARHS Status Label 270 Configuration (Software A2.08 and above).....	7-6
	AHRS 270 Label Selection: SG102 (Default).....	7-7
	AHRS 270 Label Selection: LCR100-1000.....	7-7

<b>AHRS 270 Label Selection: LISA-200</b> .....	7-7
7.1.4 Page 4: ADF/TACAN/ MKR .....	7-8
7.1.5 Page 5: NAV/ILS/DME 1 .....	7-10
7.1.6 Page 6: NAV/ILS/DME 2 .....	7-14
7.1.7 Page 7: GPS1 .....	7-17
7.1.8 Page 8: GPS2 .....	7-19
7.1.9 Page 9: FCS EMULATION .....	7-21
7.1.10 Page 10: OBS / Relay / CDI .....	7-23
7.1.11 Page 11: WX-500 .....	7-26
7.1.12 Page 12: Traffic & WXDL .....	7-27
7.1.13 Page 13: Video Setup.....	7-29
7.1.14 Page 14: STATUS .....	7-29
7.1.15 Page 15: BRT/DATA BLK .....	7-30
7.1.16 Page 16: Power .....	7-33
7.1.17 Page 17: Software CRC .....	7-34
<b>8 Appendix B: Environmental Qualification</b> .....	<b>8-1</b>
<b>9 Appendix C: Sample FAA Form 337</b> .....	<b>9-1</b>
<b>10 Appendix D: Sample Airplane Flight Manual Supplement</b> .....	<b>10-1</b>
<b>11 Appendix E: Checkout Procedures</b> .....	<b>11-1</b>
<b>11.1 Functional Ground Test Procedures/Report</b> .....	<b>11-1</b>
11.1.1 Introduction.....	11-3
11.1.2 Test Procedures and Results .....	11-3
11.1.2.1 Physical Installation.....	11-3
11.1.2.2 Wiring Verification and Initial Power-Up.....	11-3
11.1.2.3 System Configuration.....	11-4
11.1.2.4 System Functions.....	11-4
11.1.2.5 Compass System Interface.....	11-4
11.1.2.6 NAV Source Selection .....	11-5
11.1.2.7 LOC/GS Deviation.....	11-6
11.1.2.8 BRG Source Selection.....	11-6
11.1.2.9 DME Selection .....	11-7
11.1.2.10 GPS Interface and Control .....	11-8
11.1.2.11 Marker Beacon Interface.....	11-8
11.1.2.12 Flight Control System Interface.....	11-9
11.1.2.13 Stormscope ® Interface.....	11-9
11.1.2.14 Traffic.....	11-9
11.1.2.15 NVIS Control.....	11-10
11.1.2.16 Reversionary Display Control.....	11-10
11.1.2.17 Additional Testing .....	11-10
11.1.3 EMI/RFI Test Procedures.....	11-11
11.1.3.1 Nav/Com Testing .....	11-11
11.1.3.2 General Testing.....	11-11
11.1.3.3 Additional Testing .....	11-12
<b>11.2 Operational Flight Test Procedures/Report</b> .....	<b>11-13</b>
11.2.1 Introduction.....	11-15
11.2.2 Test Procedures.....	11-15
11.2.2.1 Pre-Departure Operations.....	11-15
11.2.2.2 Enroute Operations.....	11-16
11.2.2.3 GPS Approach Operations.....	11-17

11.2.2.4	ILS Approach Operations .....	11-17
11.2.2.5	TACAN Approach Operations .....	11-17
11.2.2.6	Additional Testing .....	11-18
<b>12</b>	<b>Appendix F: STC's .....</b>	<b>12-1</b>
<b>13</b>	<b>Appendix G: List of Effective Drawings and Attachments .....</b>	<b>13-1</b>

## Revision History

Revision	Date	Comments
L	12-May-2022	<p>Updated for AR 5081            Changed Microsoft Word source document format from .doc to newer .docx.            Changed references to company name from Sandel Avionics to Nighthawk Flight Systems, Inc.            Add TSO by SW revision level table including new SW revs A2.09 and 2.06</p> <p>Updated for AR 5047            Section 1.2.1: Add ADS-B traffic. Removed FIS-B Data Link weather.            Section 1.3.1: Updated Standard Density Positioners in Crimp Tool table.            Section 1.4.1: Added statement on new Label 270 options.            Section 1.4.12: Corrected SDI setting for Garmin GTN Receiver 2.            Section 1.4.16: Added statement on ADS-B In traffic.            Section 1.4.17: Updated section to state WSI data link weather no longer supported.            Section 2.3.2: Added TSO C195b.            Section 2.4.1: Corrected length of unit.            Section 2.5.1: Updated Pins 2 and 44 to add RS-422.            Section 7.1.3: Updated screen shot and configuration table to include new Label 270 options.            Section 7.1.5: Added 429 MC explanation to configuration table. Updated OBS Calibration statement to remove 400HZ Differential Resolver exclusion from calibration.            Section 7.1.6: Updated OBS Calibration statement to remove 400HZ Differential Resolver exclusion from calibration.            Section 7.1.12: Updated screen shot and configuration table to remove WSI WX selections and add new ADS-B traffic selections            Section 7.1.15: Updated Notes with statement on MOD-A external dimming voltage input.            Section 8: Updated Environmental Qualification form.            Section 13: Updated Effective Drawing List.            Section 13: Updated drawing 82009-10, Sheet 3 to correct SN4500 reference            Section 13: Updated drawing 82009-10, Sheet 24 to correct SN4500 reference            Section 13: Updated drawing 82009-10, Sheet 27 to correct GTN 6XX/7XX pins and SN4500 VERT ENA setting.            Section 13: Updated drawing 82009-10, Sheet 28 to correct GTN 6XX/7XX pins and SN4500 VERT ENA setting.            Section 13: Updated drawing 82009-10, Sheet 38 to show WSI service discontinued.            Section 13: New drawing 82009-10, Sheet 44 for ADS-B In Traffic interface.</p>
K	29-JAN-2015	<p>Updated for AR 1617            Section 1.1.1: Updated ITAR note.            Section 1.2.1: Updated ITAR note for TACAN display option.</p>

Revision	Date	Comments
J	19-NOV-2013	<p>Updated for A/R 1346</p> <p>Section 1.4.4: GTN Series added.</p> <p>Section 1.4.6: GTN6XX/7XX Added. Series resistor note removed from second paragraph.</p> <p>Section 1.4.12: Table added for GTN6XX/7XX.</p> <p>Section 2.5.1: Connector P-1 description: Removed the word “series” and removed Superflag note from pins 6 and 49.</p> <p>Section 3.3.1: P1-6, P1-48, P1-49, P1-29: Removed the word “series”.</p> <p>Section 7.1.10: Changed “OFF” Bootstrap option to “NONE”.</p> <p>Section 7.1.12: KTA-810 configuration note added.</p> <p>Section 7.1.16: Maintenance page screenshot updated to reflect new internal power supply voltage requirements.</p> <p>Section 12: Updated Effective Drawing List due to revision of 82009-10 Sheet 27 and 28 to show addition of GTN6XX/7XX Equipment Selection and addition of sheet 44 (NAV/GS Superflag).</p> <p>Section 12: Updated Drawing 82009-10, Sheet 24 to include “Superflags” in Title</p> <p>Section 12: Updated drawing 82009-10, Sheet 27 for addition of GTN6XX/7XX equipment selection.</p> <p>Section 12: Updated drawing 82009-10, Sheet 28 for addition of GTN6XX/7XX equipment selection.</p>
I	05-SEP-2012	<p>Updated for Software Version 2.05 AR 1263</p> <p>Formatting (font) updated.</p> <p>Section 7.1.2: Loc/GS pointer description updated. Added selection for ENABLE/DISABLE of inner VDI display.</p> <p>Section 7.1.10: New screenshot. Updated AUTOSLEW configuration note. Added OBS configuration selection.</p>
H	02-JUL-2012	<p>Updated for software version 2.04 AR1225</p> <p>Section 4.5: Updated procedures for use of Configuration Module.</p> <p>Section 7.1.4: Added configuration fields for DME source selection when TACAN selection is XYZ or XYZ-.</p> <p>Section 7.1.10: Updated AUTOSLEW configuration note.</p> <p>Section 7.1.15: Image updated. AUTO DISPLAY BRIGHTNESS fields updated.</p>
G	24-FEB-2012	<p>Updated for software version 2.03 AR1223</p> <p>Section 1.4.15: Updated for display brightness control.</p> <p>Section 2.5.2: Corrected descriptions for pins P2-3, 19, 21, 33 and 35.</p> <p>Section 2.5.3: Added REV Control to pin P3-13.</p> <p>Section 11.1.2.5: Changed power-on time before performing Free Gyro Mode test from 2 to 4 minutes.</p>



Revision	Date	Comments
F	10-FEB-2012	<p>Updated for software version 2.02 AR1220</p> <p>Section 1.1.1: Added TACAN ITAR Export Notice. Removed NVIS notice.</p> <p>Section 1.2.1: Roll Steering added.</p> <p>Section 1.3.1: Added table for recommended crimp tools.</p> <p>Section 1.4.21: New Roll Steering.</p> <p>Section 2.2: Bezel color part numbers corrected.</p> <p>Section 2.5.1: Corrected descriptions for pins P1-6, 7, 8, 9, 26, 29, 49 and 50.</p> <p>Section 2.5.2: Corrected descriptions for pins P2-10, 26 and 40</p> <p>Section 2.5.3: Added "TACAN Relay Out" to pins P3-2 and P3-10</p> <p>Section 2.5.4: Added description of Configuration Module.</p> <p>Section 2.6.1: Updated 429 Label Description table.</p> <p>Section 3.3.1: Updated inverter frequency range from 360 - 440Hz. to 240 - 560 Hz.</p> <p>Corrected description for pins P1-3 and 45.</p> <p>Section 3.3.2: Updated inverter frequency range from 360 - 440Hz. to 240 - 560 Hz.</p> <p>Corrected description for pins P2-11 and 41.</p> <p>Section 3.3.3: Added TACAN Relay out to P3-2 and P3-10 pinout descriptions.</p> <p>Section 4.4: Added Config Module information.</p> <p>Section 4.5: Added Config Module Status page description.</p> <p>Section 7.1.2: Added selection for heading bug color and LOC/GS Pointer.</p> <p>Section 7.1.3: Updated image for Reversion Attitude configuration.</p> <p>Section 7.1.4: Added selections for multi-channel TACAN.</p> <p>Section 7.1.5: Added selections for multi-channel DME.</p> <p>Section 7.1.6: Added selections for multi-channel DME.</p> <p>Section 7.1.10: Added configuration fields for Autoslew.</p> <p>Section 7.1.15: Updated image and description for internal brightness.</p> <p>Section 11.1.2.6: Added TACAN to NAV Source Selection ground test procedure.</p> <p>Section 13: Updated sheets 19, 40 and 43</p>
E	25-MAR-2010	<p>Updated for software version 2.01 AR1114</p> <p>Corrected TOC</p> <p>Section 3.3.2: Updated P2-3/35 pin description and added note for composite LOC DEV calibration procedure.</p> <p>Section 7.1.5: Added composite LOC DEV calibration procedure. Added reference to cal procedure and added GAIN selection to table. Updated figure.</p> <p>Section 7.1.6: Added reference to cal procedure and added GAIN selection to table. Updated figure.</p> <p>Section 11: Correct format.</p> <p>Section 11.1.2.7: Added LOC/GS deviation test.</p> <p>Section 13: updated for DWG pages 21, 22, 23, and 24.</p>
D1	11-FEB-2009	<p>Page vi: Updated revision history and corrected rev. D date 2009 to 2009.</p> <p>Page 13-2: Revised 82009-43 rev A to A1.</p>
D	12-JAN-2009	<p>Updated for software version 2.00 AR1048.</p> <p>Page vi: Updated revision history.</p> <p>Section 1.2.1: Added Optional Reversionary Display.</p> <p>Section 1.4.20: New Reversionary Display paragraph.</p> <p>Section 2.3.2: added TSO-C3d, and -C4c.</p> <p>Section 2.5.3: Added REV CNTRL Label to connector pin 6.</p> <p>Section 2.6.1: Added ARINC labels for Roll, Pitch, and Lateral Acceleration.</p> <p>Section 3.3.1: Corrected FIS-B (P1-44) pin description, removed software 3.0.</p> <p>Section 3.3.3: Added Reversionary Control signal to connector P3 pin 6.</p> <p>Section 7.1.3: Updated compass maintenance page for Reversionary Attitude.</p> <p>Section 11.1.17: Added ground test procedure.</p> <p>Section 12: Removed scanned docs and replaced with reference to website.</p> <p>Page 13-2: Added 82009-43 to drawing list.</p>

Revision	Date	Comments
C	22-SEP-2008	<p>Updated for software version 1.05 AR1033</p> <p>Page vi: Updated revision history.</p> <p>Page 1-1: Added export control notice and NVIS feature.</p> <p>Page 1-9: Night Vision and TACAN support notes added.</p> <p>Page 2-1: Added dash number definitions.</p> <p>Page 2-2: BOM: Corrected description of P/N 32073 and removed P/N 60144</p> <p>Page 2-5: TACAN added.</p> <p>Page 2-9: TACAN added.</p> <p>Page 2-9: Corrected reference in P2-16 description from P1-16 to P1-22.</p> <p>Page 2-12: Assigned P3-13 to NVIS Control</p> <p>Page 2-15: TACAN labels added.</p> <p>Page 3-4: TACN added.</p> <p>Page 3-7: Changed remote course Y input pin to P1-61.</p> <p>Page 3-8: TACAN added.</p> <p>Page 3-11: Added NVIS P3-13 description.</p> <p>Page 7-2 Updated Index maintenance page.</p> <p>Page 7-3: Updated System maintenance page.</p> <p>Page 7-7: Updated maintenance page image to show TACAN. Added TACAN configuration fields.</p> <p>Page 7-13 / 7-14: Revised comments in the VERT DV, VERT ENA, APR ACTV, and GPS configuration fields.</p> <p>Page 7-15 / 7-16: Revised comments in the VERT DV, VERT ENA, APR ACTV, and GPS configuration fields.</p> <p>Page 7-19: Added fields for RMT CRS and RMT HDG.</p> <p>Page 7-23: Updated Status maintenance page.</p> <p>Page 10-2 Updated sample AFMS language for Heading Repeater installation.</p> <p>Page 11-3: NVIS added to introduction list.</p> <p>Page 11-5: Added heading repeater to ground test.</p> <p>Page 11-6: TACAN added to BRG Source Selection check.</p> <p>Page 11-9: Added NVIS test.</p> <p>Page 11-15: Added TACAN check to Enroute Operations.</p> <p>Page 11-16: Added TACAN approach operations.</p> <p>Page 13-2: Added 82009-41 and -42 to drawing list.</p>
B1	21-DEC-2007	<p>Updated for software version 1.03</p> <p>Page vi: Updated Revision History</p> <p>Page 7-14: Updated GPS-1 maintenance page.</p> <p>Page 7-16: Updated GPS-2 maintenance page.</p> <p>Page 7-23: Added Video Setup maintenance page.</p> <p>Pages 13-1, 13-2: Updated Effective drawing list</p> <p>Revised 82009-10 sheets 28, 33, 34 and 38</p> <p>Added 82009-10 sheet 40.</p>
B	07-NOV-2006	Updated for conformance to Software version 1.01 per AR 867.
A	09-FEB-2006	Initial release

# 1 General Information

## TSO by SW revision level

SN4500 SW Revision		Applicable TSOs
Base Hardware	Mod-A Hardware	
All		<p>TSOs C113, C6d, C34e, C35d, C36e, C40c, C41d, C118, C119b</p> <p>TSO-C113 Airborne Multipurpose Electronic Displays</p> <p>TSO-C6d Direction Instrument, Magnetic (Gyroscopically Stabilized)</p> <p>TSO-C34e ILS Glide Slope Receiving Equipment Operating Within The Radio Frequency Range of 328.6-335.4 Megahertz</p> <p>TSO-C35d Airborne Radio Marker Receiving Equipment</p> <p>TSO-C36e ILS Localizer Receiving Equipment Operating Within The Radio Frequency Range of 108-112 Megahertz</p> <p>TSO-C40c VOR Receiving Equipment Operating within the Radio Frequency Range of 108-117.95 Megahertz (MHz)</p> <p>TSO-C41d Airborne Automatic Direction Finding (ADF) equipment</p> <p>TSO-C118 Traffic Alert and Collision Avoidance System (TCAS) Airborne Equipment, TCAS I</p> <p>TSO-C119b Traffic Alert and Collision Avoidance System (TCAS) Airborne equipment, TCAS II</p>
2.00-Later	All	<p>TSOs C113, C3d, C4c, C6d, C34e, C35d, C36e, C40c, C41d, C118, C119b</p> <p>TSO-C3d Turn and Slip Instruments</p> <p>TSO-C4c Bank and Pitch Instruments</p>
2.06-Later	A2.09-Later	<p>TSOs C113, C3d, C4c, C6d, C34e, C35d, C36e, C40c, C41d, C118, C119b, C195b</p> <p>TSO-C195b Avionics Supporting Automatic Dependent Surveillance-Broadcast(ADS-B) (ASA)</p>

### 1.1 Introduction

The Nighthawk Flight Systems, Inc. Sandel SN4500 Primary Navigation Display is the industry's most capable electronic HSI. It can be used to directly replace a mechanical DG or HSI as a primary display. The information contained within this Installation Manual describes

the features, functions, technical characteristics, components, approval procedures, installation considerations, setup procedures, checkout procedures, and instructions for continued airworthiness for the SN4500.

### 1.1.1 EXPORT CONTROL NOTICE

Prior to 20 January, 2015 - The TACAN display option software key (p/n 90169-TCN) is subject to the licensing jurisdiction of the Department of State in accordance with the International Traffic in Arms Regulations (ITAR) (22 CFR 120 – 130). It may not be exported (sent, transferred, disclosed or otherwise released to a foreign person) without a license issued by DDTC.

## 1.2 Equipment Description

### 1.2.1 Features

The SN4500 is an advanced microprocessor controlled airborne multipurpose electronic display which is FAA approved under technical standard orders (TSO) – C 3d, C4c, C6d, -C34e, -C35d, -C36e, -C40c, -C41d, C113, C118, C119b, and C195b. The SN4500 is also EASA approved under ETSO 2C34f, 2C35d, 2C36f, 2C40c, 2C41d, C113, C118, C119b, and C6d. The SN4500 employs a patented active matrix liquid crystal (AMLCD) projection display. It is designed to combine the functions of:

- **Basic Horizontal Situation Indicator (HSI)**
- **Long-Range Navigation (GPS or FMS) Map Display**
- **WX-500 Stormscope® Display**
- **DME Readout**
- **Marker Beacon Indicator**
- **NAV Converter**
- **Autopilot Switching**
- **GPS Annunciators and External Mode Switches**
- **Optional Traffic Display (ADS-B In supported in Software A2.09 or later and 2.06 or later)**
- **Optional TACAN interface – (Prior to 20 January, 2015 - ITAR Export Controlled) (Software 1.05 or later)**
- **Optional Class B Night Vision (NVIS) Compatible (Software 1.05 or later)**
- **Optional Reversionary Attitude Display (Software 2.00 or later)**
- **Optional Roll Steering Command output to Autopilot (Software 2.02 or later)**

Outputs of heading and course datum and bootstrap heading output are provided, as well as L/R and U/D deviation output and flags. The versatile digital and analog interface properties of the unit provide for compatibility with most VHF navigation receivers, TACAN's, ADF's, DME's, GPS's, remote gyros and flux gates.

Inputs for remote course and heading selection (XYZ) are provided.

The SN4500 is designed to display the flight plan data from a connected GPS receiver. The moving map database for the SN4500 as well as the internal operating system software are field

loadable through the use of a portable computer equipped with a USB port and Microsoft Windows.

Although simple, retrofit replacement of most existing four-inch PNI's or HSI's is possible without additional features, we strongly encourage complete installation of the unit with all compatible peripheral equipment interconnected to maximize its functional capability.

## 1.3 Installation Planning

Nighthawk Flight Systems, Inc. has taken many equipment interface possibilities into consideration during the design of the SN4500 to ensure maximum interoperability with other avionics. Contact the factory with any questions about interfacing to specific avionics equipment not covered in the installation drawings.

To simplify installation and installation planning, signals are wired to the SN4500 pins per the installation diagrams and software setups are used in a post-installation procedure to assign protocols/gradients to each pin based on the equipment connected. There are separate maintenance menu pages for each equipment function and in most cases the selections are made by equipment make/model.

### 1.3.1 Installation Planning Cycle

- 1) Compile an equipment list for the aircraft.
- 2) Study the feature list below and determine the desired functional characteristics for the installation.
- 3) Study the installation drawings to determine a basic interconnect scheme and check for conflicts.
- 4) Develop the specific wiring diagrams unique to the aircraft.
- 5) Assemble required tools. Recommended crimp tools are given in the following table.

<b>Recommended Crimp Tools</b>					
		<b>High Density 22-28 AWG</b>		<b>Standard Density 20-24 AWG</b>	
<b>Manufacturer</b>	<b>Hand Crimping Tool</b>	<b>Positioner</b>	<b>Insertion/ Extraction Tool</b>	<b>Positioner</b>	<b>Insertion/ Extraction Tool</b>
Military P/N	M22520/2-01	M22520/2-09	M81969/1-04	9502-10-0-0	M81969/1-02
Positronic	9507	9502-3	M81969/1-04	9502-10-0-0	M81969/1-02
ITT Cannon	995-0001-584	995-0001-739	N/A	995-0001-604	980-2000-426
AMP	601966-1	601966-6	91067-1	601966-5	91067-2
Daniels	AFM8	K41	M81969/1-04	K694	M24308/1-02
Astro	615717	615725	M81969/1-02	615724	M81969/1-02

### 1.3.2 Post Installation Summary

- 1) Prior to power-up, review correct wiring by using standard ohmmeter and voltage checks.
- 2) Review special items such as connection of the NAV receiver resolver wiring.
- 3) Apply power to the SN4500, bring up in maintenance mode and sequentially access each SN4500 maintenance page to correctly select the installed equipment.
- 4) Perform Ground Test procedures
- 5) Perform Flight Test procedures.

## 1.4 Interface Planning

### 1.4.1 Compass System

Determine whether the SN4500 is to be used internally slaved or unslaved. Unslaved operation would be appropriate when the SN4500 is bootstrapped to an already slaved compass system.

Plan for:

1. 3-wire ARINC 407 synchro remote DG self-slaved. (SN4500 unslaved)
2. 3-wire ARINC 407 unslaved synchro DG with or without gyro valid output and fluxgate. (internal slaving)
3. ARINC 429 Heading Input from AHRS. The unit monitors for Label 320, Magnetic Heading Data and Label 270 System Status (SN4500 unslaved). See section 7.1.3 for Label 270 options available in software version A2.08 and above.
4. Quadrature stepper motor drive input from a Bendix/King KG 102 series DG with compass valid output and flux gate connected directly to SN4500 (internal slaving).
5. High Resolution Digital Output from a Mid-Continent 4305 series DG with gyro valid output, flux gate 10 Vac Fluxgate Excitation and Internal 26Vac Inverter (internal slaving)

Internal slaving requires connection of the flux gate excitation to the SN4500 flux gate reference input P2-24. This input is used only to demodulate the flux gate signals.

DG's with XYZ bootstrap output requires the master 400Hz inverter to be connected to the SN4500 400Hz reference input on P1-22. This input is used to lock all 400Hz inputs on P1 and 400Hz outputs in the SN4500. This input presents less than 1mA loading to the source.

Follow the information on the installation drawings, and plan to set up the appropriate compass selections on the compass system maintenance page.

Internal slaving does not require the use of an external slaving accessory. Compass calibration is performed using the SN4500 Compass maintenance page. The SN4500 will provide standby heading operation from the flux gate alone in the event of directional gyro (DG) failure.

The SN4500 has a 3-wire ARINC 407 synchro bootstrap compass output if required which is capable of driving electronic loads.

#### 1.4.2 Autopilot Switching

The SN4500 has low level deviation and flag outputs intended to drive an autopilot. These outputs feed from the pilot selected navigation source. These outputs may eliminate the need for an external autopilot switching relay.

However if an external switching relay is used (for instance for compatibility with an existing installation) the SN4500 has protected Open Drain relay output discrettes intended to drive external switching relays. These outputs have 250ma maximum current and pull to within 1 ohm of ground.

NAV1 selection is the default selection and no relay driver output discrete is available. The NAV-2, GPS-1 (FMS-1), or GPS-2 (FMS-2) outputs can be used to operate a switching relay for each source, allowing the pilot to control the NAV source selection from the front panel of the SN4500. This is referred to as “master” mode and it is the preferred mode of installation. In this configuration an additional remote switch/annunciator panel for a GPS receiver is not required.

In the event the aircraft has an existing GPS switch/annunciator panel or it is desired that one be installed, the “GPS SELECTED-” input on the SN4500 is used to remote sense the selection of the GPS1 and annunciate the selection. This is referred to as “slave” mode. It allows annunciation of the selection on the SN4500 but does not use the front panel NAV switch to select the GPS receiver. This mode is only available for use with a single GPS.

Master/Slave mode selection is done in the OBS/NAV/RELAY/CDI maintenance page.

When any relay is used, the SN4500 uses a wraparound RELAY SENSE input, which provides feedback of failure of the switching relay. A pole on the external relay is used to ground an SN4500 input pin when the relay is in the energized position. If the low signal is not detected, the SN4500 annunciates the relay failure by redlining the NAV source display.

#### 1.4.3 Autopilot Course and Heading Datum

Course and heading datum outputs are provided. These can be AC or DC depending on whether Datum Excitation is connected. The direction sense of these signals can be reversed as required.

A Back-course discrete output is provided for annunciation or AFCS reverse-course control when required. This operates during LOC operation when the aircraft is flying with the tail of the Course Pointer up.

For older Century autopilots an external transformer coupler must be fabricated. See installation drawings.

#### 1.4.4 GPS (FMS) Annunciators

For receivers without serial communication capability, discrete annunciator inputs are provided for ARM, ACT, WPT or HLD, MSG, OBS/LEG Mode, and Parallel Track. Connect the pins appropriate to the installed receiver and select the receiver type on the LNAV maintenance page. See GPS/SWITCH/ANNUNCIATORS Installation drawing for the complete matrix of outputs and annunciators.

Discrete control outputs are provided for APPR ARM, OBS Mode (King KLN90) and HOLD (Garmin). These are open-drain outputs.

The Garmin GNS/GTN receivers use ARINC 429 for the annunciator functions so no discrete connections are used.

#### 1.4.5 VLOC Navigation – Internal NAV Converter

For new installations that do not already have an external NAV converter, the SN4500 supports *internal* demodulation of composite NAV and Localizer to supply the display and autopilot outputs with L/R deviation and course selection. See the appropriate installation drawings.

#### 1.4.6 VLOC Navigation – External NAV Converter

The SN4500 has a single, conventional set of low level analog inputs for deviation, flags, etc. from a primary NAV receiver. See the installation diagram for details. These inputs are not used when the Garmin GNS430/530/GTN6XX/7XX ARINC NAV receiver, which uses ARINC 429 only, is being used. If more than one receiver is used which has analog signaling, this will require switching relays to feed the single set of SN4500 inputs. Deviation-only NAV converters not providing bearing information are supported.

There are only low level flag inputs. If it is desired to use a Superflag instead of a low-level flag from the NAV receiver, see the installation drawings.

Optional ILS lockout of the GPS selection is provided by an ILS Energize 1/2 input pins. This feature can be disabled on the NAV maintenance page. In the Master mode this will cause the SN4500 to revert to and annunciate NAV1 when an ILS is tuned on NAV1, or NAV2 when an ILS is tuned on NAV2. Disabling of ILS lockout is called for when the customer does not want ILS lockout operation, or when a GPS receiver with vertical guidance is used to drive the ILS Energize pin during GPS operation. In this situation NAV1/GPS1 use ILS Energize 1, and NAV2/GPS 2 use ILS Energize 2 to display vertical guidance.

For analog receivers, two types of resolvers are supported.

- a) An electronic OBS resolver with rotor input and SIN/COS outputs is provided. An associated DC reference pin must be connected to the stator low-side connection of the NAV receiver. This may be ground but may also be a DC reference voltage of approximately 4.5vdc. **WARNING:** You must check the NAV receiver wiring



before installation planning and before applying power to the system to prevent NAV receiver damage from inadvertent miswiring. Refer to the installation drawing.

This resolver will operate from 30Hz to 500Hz and is calibrated in the NAV maintenance page.

#### 1.4.7 400Hz Differential Resolver

A single electronic 400Hz differential resolver is provided for use with 400Hz receivers such as Collins VIR-30A. This interconnect uses SIN/COS inputs (Z-ground referenced) and SIN/COS outputs (Z-ground referenced).

#### 1.4.8 Marker Beacon

Three inputs are provided for a Marker Beacon repeater. These are DC level-sensitive inputs. The thresholds and logic levels are adjusted by selection of the appropriate equipment type on the MKR maintenance page. Lamp load resistors are internal.

The SN4500 can also monitor label 222 when marker beacon data is provided from an ARINC 429 source.

#### 1.4.9 Bearing Pointers (VOR, ADF, and TACAN)

The bearing pointers can derive their information from any of the connected navigation receivers, including two composite NAV inputs, ADF's, TACAN's and the long range navigation receivers through the serial ports.

ADF's can be connected as ARINC 407 synchro or DC SIN/COS inputs. See the installation drawings for interconnection data and select the appropriate format from the ADF maintenance page.

The composite NAV inputs accept standard 0.5v ARINC inputs. For 3v inputs a series resistor is required, please see the appropriate installation drawing. Selection of 0/180 phase is made by the appropriate maintenance page calibration.

#### 1.4.10 ARINC Channels

The SN4500 contains universal inputs capable of communicating with ARINC 429, ARINC 419, RS232 and Analog. All equipment capable of ARINC compatibility (such as GPS/FMS, Navigation, Traffic, etc) can be directly connected to the appropriate signal input. There are a total of 17 compatible ARINC inputs.

#### 1.4.11 DME Interface

DME inputs support ARINC 429, ARINC 568, King serial, or single analog (40mV/mile) inputs.

#### 1.4.12 Special Considerations for GARMIN GNS430/530/GTN6XX/7XX

<b>Required SN4500 Setup Items</b>	
<b>Maintenance Page Items</b>	Study the Sandel Maintenance Page Items on the appropriate GNS430 installation drawings and set as indicated.
<b>Relay Mode</b>	MASTER
<b>ILS Lockout</b>	OFF

<b>Required GARMIN GNS430 Setup Items, Receiver 1</b>		
<b>Software</b>	Main 1.00 or later	
<b>Main ARINC 429 Configuration</b>	IN 1: Low, Sandel EHSI	
	OUT: Low, GAMA 429 Grph w/Int	Note: <u>NOT</u> ARINC 429!
	SDI: LNAV1	SDI1
<b>VOR/LOC/GS ARINC 429 Configuration</b>	Speed RX: Low	
	Speed TX: Low	
	SDI: VOR/ILS 1	SDI1

<b>Required GARMIN GNS430 Setup Items, Receiver 2</b>		
<b>Software</b>	Main 1.00 or later	
<b>Main ARINC 429 Configuration</b>	IN 1: Low, Sandel EHSI	
	OUT: Low, GAMA 429 Grph w/Int	Note: <u>NOT</u> ARINC 429!
	SDI: LNAV2	SDI2
<b>VOR/LOC/GS ARINC 429 Configuration</b>	Speed RX: Low	
	Speed TX: Low	
	SDI: VOR/ILS 2	SDI2

<b>Required Garmin GTN 6xx/7xx Setup Items, Receiver 1</b>		
<b>Software</b>	Main 5.0 or later	
<b>Main ARINC 429 Configuration</b>	IN 1: EFIS Format 4	
	OUT: GAMA Format 3	
	SDI LNAV1	SDI1
<b>VOR/LOC/GS ARINC 429 Configuration</b>	Speed RX: Low or High as needed	
	Speed TX: Low or High as needed	
	SDI: VOR/ILS1	SDI1

<b>Required Garmin GTN 6xx/7xx Setup Items, Receiver 2</b>		
<b>Software</b>	Main 5.0 or later	
<b>Main ARINC 429 Configuration</b>	IN 1: EFIS Format 4	
	OUT: GAMA Format 3	
	SDI LNAV2	SDI2
<b>VOR/LOC/GS ARINC 429 Configuration</b>	Speed RX: Low or High as needed	
	Speed TX: Low or High as needed	
	SDI: VOR/ILS2	SDI2

1.4.13 Special Considerations for GNS XLS Users

The SN4500 will display the arc segment on a published approach incorporating a DME arc in one of three different ways depending on the arc style configuration selected in the GNS-XLS. Consult the GNS-XLS installation manual for configuration details.

Configuring the GNS-XLS for:

<b>ARC Style</b>	<b>ARC Display</b>
<b>ARC TO AT END</b>	DME arcs are displayed in magenta when it is the active portion of the flight plan otherwise they will be displayed in white.
<b>ARC TO ON ARC</b>	DME arcs are always displayed in white.
<b>ARC AS GAP</b>	DME arcs are not displayed. A straight line will be drawn from the beginning of the ARC to the waypoint at the end of the ARC. The color of the line will be magenta when it is the active portion of the flight plan otherwise it will be displayed in white.

1.4.14 Special Considerations for UPS GXXX

<b>Configuration Notes:</b>	
<b>GX Series Notes:</b>	In Setup, enable Extended MovMap Data Format
<b>SN4500 Unit:</b>	Set LNAV selection to IIMorrow GX (RS-232 ENH) Vertical deviation (if desired) requires the ILS ENG input pin pulled low.
<b>Testing</b>	The GX unit will not output RS-232 data in manual test mode Upon power on, the GX will go through IFR Output Test Mode and the following test can be observed: CDI & Flags

	VDI & Flags (if enabled on Sandel) Annunciators
--	--

#### 1.4.15 Display Brightness Control

The SN4500 supports either internal or external control of the display brightness selectable on the BRT/DATA BLK maintenance page. When internal control is selected, the keypad brightness level is adjustable using the right knob in the pulled out position when the pilot selectable dimming option is set to manual. When dimming option is set to auto, the brightness will be controlled by an internal light sensor mounted on the front bezel.

External brightness control can be selected when the SN4500 is interfaced to the aircraft dimmer bus. Settings for 5VDC, 5VAC or 28VDC are provided. Maximum and minimum brightness dimmer bus voltage thresholds can be set on the BRT/DATA BLK maintenance page. A broken connection between the dimmer bus and the SN4500 will result in reverting to internal brightness control.

See the SN4500 Pilots Guide for a complete description of the operation of the display and button brightness control.

#### 1.4.16 Traffic Option

The SN4500 supports Traffic input from TCAS or TAS receivers via single ARINC 429 High Speed. Purchase of a key code to enable the Traffic display is required.

Some remote traffic processors may require remote switches, See the Traffic interface drawings in this manual for these requirements.

When interfaced to a TCAS II remote processor, the SN4500 can only be used as a secondary display as it will not display vertical guidance for the purpose of resolution advisories.

ADS-B In traffic is supported in software version A2.09 and above or 2.06 and above through an RS-422 serial interface.

#### 1.4.17 Data Link Weather Option

WSI data link weather is no longer supported. Flight Information Services-Broadcast (FIS-B) data link weather from ADS-B In receivers will be supported in the future.

#### 1.4.18 Night Vision Support Option

For NVIS capable units NVIS mode is enabled by a closure to ground through an external toggle switch or maintained pushbutton switch. NVIS mode is annunciated onscreen so an external annunciator is not required.

The input will always pull up to the de-activated state when disconnected.

#### 1.4.19 TACAN Option

The SN4500 supports TACAN input via ARINC 419, ARINC 429, and Arinc 407 Synchro (XYZ). A TACAN key code is not required for maintenance page setup however, purchase of a key code to enable the TACAN display is required. When configured, TCN will not appear as a NAV source selection or on the bearing pointer source list if the TACAN key is not valid. See the TACAN interface drawings in this manual for interface wiring requirements.

#### 1.4.20 Reversionary Attitude Option

The SN4500 supports a Reversionary Attitude Display when interfaced to an Attitude Heading Reference System supplying Roll, Pitch, Heading, and lateral acceleration data via Arinc 429. An optional key code is required to enable this feature. See the Reversionary Control interface drawing in this manual for interface wiring requirements. This option is not available when the SN4500 is interfaced to an analog DME.

#### 1.4.21 Roll Steering Option

An optional Roll Steering option has been added with software version 4.04 or later which adds the capability for the GPS navigator to precisely fly a GPS flight plan including high angle course intercepts and holding patterns. The GPS must support sending Arinc 429 label 121. There are no additional installation considerations to the autopilot other than previously mentioned. An optional key code is required to enable this feature.

## 1.5 Disclaimer

Nighthawk Flight Systems, Inc. does not assume any risk for nor accept any responsibility for the interface descriptions contained within this Installation Manual. It is the responsibility of the installer to ensure that such equipment is compatible with the SN4500 as described, and to ensure that the installation of the SN4500 is accomplished with such equipment using the specific equipment manufacturer's installation and technical instructions. No other representations are expressed herein.

## 2 Technical Information

### 2.1 General

The SN4500 is enclosed in an ARINC 408, 4ATI form factor enclosure and is mounted to an instrument panel using a standard ATI clamp.

The SN4500 operates on an input voltage from 22 to 33 Volts DC, nominal 40 watts. 26 Volts AC 400 Hertz reference excitation inputs with a current requirement of less than 1 milliampere are required when the functions of AC synchro inputs or outputs are required for use with peripheral equipment. These reference excitation signals must be obtained from the correct aircraft inverter source. A third inverter input ‘Datum Excitation’ is available and is specifically used in situations where the autopilot uses an additional inverter or the autopilot inverter frequency is higher than 400Hz.

The following section describes the technical characteristics that include the appliance approval basis, physical and electrical properties, electrical connector pin allocation which details function and gradient or equipment protocol, and ARINC label support. Also included is the description of the SN4500 installation components, other equipment and installation requirements. A review of the installation approval procedures is provided for filing with authorities.

### 2.2 Part Numbers

The part number for the Sandel SN4500 is:

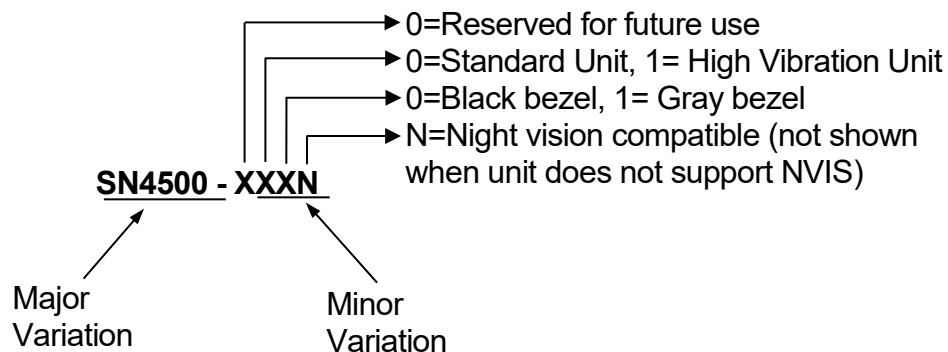

The current version of software is displayed on the power-up screen.

#### 2.2.1 Installation Kit and Accessories

SPN	Description
90169-IK	SN4500 installation kit

#### 2.2.2 Bill of Materials – SN4500 Install Kit

SPN	Description	Qty
32062	Conn., D-15 with pins (Positronics P/N SD15F10JVL0)	1
32063	Conn., D-44 with pins (Positronics P/N DD44F10JVL0)	1
32073	Conn., D-62 with pins (Positronics P/N DD62F10JVL0)	1
61186	4ATI Mounting Clamp	1
82009-IM	Installation Manual, SN4500	1

## 2.3 Approval Summary

2.3.1 License Requirements  
None.

2.3.2 Approval Data

Technical Standard Order: TSO-C113, “Airborne Multipurpose Electronic Displays”  
 TSO-C3d, “Turn and Slip Instrument”  
 TSO-C4c, “Bank and Pitch Instruments”  
 TSO-C6d, “Direction Instrument, Magnetic (Gyroscopically Stabilized)”  
 TSO-C34e, “ILS Glide Slope Receiving Equipment Operating Within The Radio Frequency Range of 328.6-335.4 Megahertz”  
 TSO-C35d, “Airborne Radio Marker Receiving Equipment”  
 TSO-C36e, “Airborne ILS Localizer Receiving Equipment Operating Within The Radio Frequency Range of 108-112 Megahertz”  
 TSO-C40c, “VOR Receiving Equipment Operating within the Radio Frequency Range of 108-117.95 Megahertz (MHz)”  
 TSO-C41d, “Airborne Automatic Direction Finding (ADF) equipment”  
 TSO-C118, “Traffic Alert and Collision Avoidance System (TCAS) Airborne Equipment, TCAS I”  
 TSO-C119b, “Traffic Alert and Collision Avoidance system (TCAS) Airborne equipment, TCAS II”  
 TSO-C195b, “Avionics Supporting Automatic Dependent Surveillance – Broadcast (ADS-B) Aircraft Surveillance Applications (ASA)”

Software Certification: RTCA/DO-178, Level C  
 Hardware Certification: RTCA/DO-254, Level C  
 Environmental Categories: RTCA/DO-160E

### 2.3.3 Technical Standard Order Stipulation

The following stipulation as presented is required by the Federal Aviation Administration for articles approved under Technical Standard Order. This statement does not preclude multiple installation and operational approvals in regard to specific aircraft make, model, or type:

**The conditions and tests required for TSO approval of this article are minimum performance standards. It is the responsibility of those installing this article either on or within a specific type or class of aircraft to determine that the aircraft installation conditions are within the TSO standard. TSO articles must have separate approval for installation in an aircraft. The article may be installed only if performed under 14 CFR part 43 or the applicable airworthiness requirements.**

### 2.3.4 Installation and Operational Approval Procedures

For the purpose of seeking installation approval, declarations should be made in the “Description of Work Accomplished” section of a Federal Aviation Administration (FAA) Form 337 or other field approval, or other limited supplemented type certification form. A sample Form 337 is included in the Appendix. The basis of approval is for use as a primary navigation display for the functions of basic directional and navigational information. Moving map operations of the SN4500 is to be approved as supplemental means for VFR or IFR navigation, consistent with the approval of the long-range navigation system. See appropriate FAA Advisory Circular (AC) or other guidance on Loran-C, GPS, FMS, or INS for approval methods of such equipment. Applicable Federal Aviation Regulations (FAR) must be adhered to.

Flight Standards Information Bulletin, FSAW 95-09d, titled: “Electronic Horizontal Situation Indicator (EHSI) Approvals” was originally published for the purpose of assisting Aviation Safety Inspectors with approval authority and methods for conducting a field approval for electronic HSI’s. This FSIB describes the qualification of displays intended for use as essential, not critical, to preclude the need to conducting additional testing to substantiate immunity to high intensity radiated fields (HIRF) requirements.

The Environmental Qualification Form for the SN4500 is included in the Appendix and should be referenced to the categories appropriate to the aircraft type and environment into which the SN4500 is to be installed. The environmental category for the SN4500 should be stipulated on the FAA Form 337, or other approval form.

A “Functional Ground Test Procedures/Report” and an “Operational Flight Check Procedures/Report” is also included in the appendix and should be used as a basis for validating the SN4500 equipment configuration and for verifying proper installation and functional performance. A copy of this form should be submitted along with the FAA Form 337, or other approval or certification form. A permanent copy must be filed and maintained by the installing agency. Another copy must be presented to the aircraft owner for entry into the aircraft maintenance records, as well as a copy forwarded to Nighthawk Flight Systems, Inc. along with the Warranty Registration Form, Part Number 82009-0137, to be filed after completion and installation acceptance. If any difficulty is experienced with the functionality or operational performance of the SN4500, contact Nighthawk Flight Systems, Inc. for assistance.



## 2.4 Physical, and Electrical Properties

### 2.4.1 Physical Dimensions

Form Factor:	4ATI (ARINC 408)
Width:	3.975 in. (10.10 cm.)
Height:	3.975 in. (10.10 cm.)
Length:	9.78 in. (24.84 cm.) overall flush to bezel; 9.45 in (24.00 cm) measured from rear of bezel.
Weight:	3.5 lbs. (1.6 Kg.)
CG:	4.7" from rear of bezel.
ATI Clamp:	Nighthawk Flight Systems, Inc. P/N 61186 or equivalent.
Cooling Requirements:	Internal fan requiring ambient air at fan input.

### 2.4.2 Summary Operational Characteristics

Temperature Altitude:	-20° C to +70° C – up to 55,000 feet
Power Inputs:	28 Vdc @ 1.4A nominal (40 watts)

## 2.5 Connector Summary

The SN4500 is designed to interface and operate with several generations of avionics equipment. It is compatible with DC analog and/or ARINC standard synchro and serial digital signals, as well as industry standard and adopted AC and DC sine, cosine, and discrete input and output voltages. The SN4500 design and operation is optimized for efficient adaptability to both new and existing avionics equipment and systems.

The lists on the following pages reflect the configurable input and output signal types for various equipment types. See “SETUP PROCEDURES” on page 4-1 for more information on maintenance setup pages.

2.5.1 Connector P1

Pin #		Name	Signal Type (dependent on maintenance page selection)
	22	<b>Inverter Exc.</b>	In <i>Inverter</i> Note: May be same or different than P2-16 inverter source. 26VAC Excitation for items on connector P1
1		<b>Shield Gnd</b>	
	43	<b>TCAS 1A</b>	In <i>A429 (RS422) (RS232)</i> A side 429 + side 422 Ground side
	23	<b>TCAS 1B</b>	In <i>A429 (RS422) (RS232)</i> B side 429 - side 422 Rx
2		<b>ADS-B Data link 1A</b>	In <i>A429 (RS422) (RS232)</i> A side 429 + side 422 Ground side
	44	<b>ADS-B Data link 1B</b>	In <i>A429 (RS422) (RS232)</i> B side (429) - side 422 Rx
	24	<b>N/C</b>	
3		<b>Hdg1A</b>	In <i>A429 A407 Stepper A</i> A side 429 Synchro X [Z grounded] Bendix/King stepper Phase A
	45	<b>Hdg1B</b>	In <i>A429 A407 Stepper C</i> B side 429 Synchro Y [Z grounded] Bendix/King stepper phase C
	25	<b>Hdg1 Valid</b>	In <i>Discrete Valid</i> Hdg Analog, Note: Not used when 429 is data source.
4		<b>ADF1A TACAN 2A</b>	In <i>A429 A419 DC Sin A407</i> A Side 429 A side 419 (TACAN only) DC Sine Synchro X [Z grounded]
	46	<b>ADF1B TACAN 2B</b>	In <i>A429 A419 DC Cos A407</i> B Side 429 B side 419 (TACAN only) DC Cosine Synchro Y [Z grounded]
	26	<b>ADF1 DC Ref</b>	In <i>ADF Ref</i> ADF DC, Note: Not used when 429 or XYZ is data source.
5		<b>ADF1 Valid</b>	In <i>Discrete Valid</i> ADF Discrete, Note: Not used when 429 is data source
	47	<b>WX500 1A</b>	In <i>A429 (RS422) (RS232)</i> A side 429 + side 422 Ground side
	27	<b>WX500 1B</b>	In <i>A429 (RS422) (RS232)</i> B side 429 - side 422 Rx

**P1 Connector (continued from previous page)**

Pin #		Name	Signal Type (dependent on maintenance page selection)	
6		<b>GS1 LL Flag In+</b>	In <i>Flag</i>	Differential pair to pin 48. See installation drawing for resistor required.
	48	<b>GS1 LL Flag In-</b>	In <i>Flag</i>	Differential pair to pin 6.
	28	<b>GS1 LL Dev In +FLY DOWN</b>	In	Differential pair to pin 7. Polarity: + indicates above glideslope, fly-down indication
7		<b>GS1 LL Dev In +FLY UP</b>	In	Differential pair to pin 28. Polarity: + indicates below glideslope, fly-up indication.
	49	<b>LAT1 LL Flag In+</b>	In <i>Flag</i>	Differential pair to pin 29. See installation drawing for resistor required.
	29	<b>LAT1 LL Flag In-</b>	In <i>Flag</i>	Differential pair to pin 49.
8		<b>LAT1 LL Dev In +FLY RIGHT</b>	In	Differential pair to pin 50. Polarity: + indicates left of course, fly-right indication
	50	<b>LAT1 LL Dev In +FLY LEFT</b>	In	Differential pair to pin 8. Polarity: + indicates right of course, fly-left indication.
	30	<b>To/From In+</b>	In <i>Flag</i>	Differential pair to pin 9 Note: For use with external SUPERFLAG see installation drawing for series resistor required.
9		<b>To/From In-</b>	In <i>Flag</i>	Differential pair to pin 30.
	51	<b>DME 2 CLK</b>	In <i>A568 A429</i>	A side 429
	31	<b>DME 2 DATA</b>	In <i>A568 A429</i>	B side 429
10		<b>DME 2 SYNC</b>	In <i>A568</i>	
	52	<b>DME 2 Hold DME 1/2</b>	In <i>Discrete</i>	
	32	<b>DIFF RSLVR SIN IN</b>	<i>(A407)</i>	Synchro X
11		<b>DIFF RSLVR COS IN</b>	<i>(A407)</i>	Synchro Y

**P1 Connector (continued from previous page)**

Pin #		Name	Signal Type (dependent on maintenance page selection)
	53	<b>IM</b>	Marker In
	33	<b>MM</b>	Marker In
12		<b>OM</b>	Marker In
	54	<b>429 Out A</b>	Out (Spare for future use) A429 A Side
	34	<b>429 Out B</b>	Out (Spare for future use) A429 B Side
13		<b>RS232TxD</b>	(Out (R232)
	55	<b>WPT</b>	In Discrete
	35	<b>MSG</b>	In Discrete
14		<b>ACT</b>	In Discrete
	56	<b>ARM</b>	In Discrete
	36	<b>N/C</b>	
15		<b>OBS/LEG</b>	In Discrete
	57	<b>RDR-708A</b>	Not implemented, reserved.
	37	<b>RDR-708B</b>	Not implemented, reserved.
16		<b>DR</b>	In Discrete
	58	<b>ILS Energize 1 Alternate Discrete In</b>	In Discrete Discrete Open/+28Vdc
	38	<b>ILS Energize 2 Alternate Discrete In</b>	In Discrete Discrete Open/+28Vdc
17			RESERVED
	59		RESERVED
	39		RESERVED
18			RESERVED
	60		RESERVED
	40		RESERVED

19			<b>Rmt CRS X</b>	A407	Synchro X [Z grounded]
		61	<b>Rmt CRS Y</b>	A407	Synchro X [Z grounded]
	41		<b>GND</b>		
20			<b>Rmt HDG X</b>	A407	Synchro X [Z grounded]
		62	<b>Rmt HDG Y</b>	A407	Synchro X [Z grounded]
	42		<b>GND</b>		
21			<b>Rmt Dimmer</b>	In Analog	

Note 1. 3 volt composite inputs require the use of a series resistor. See installation drawings.

Note 2: For XYZ inputs Z is signal ground P1-1.

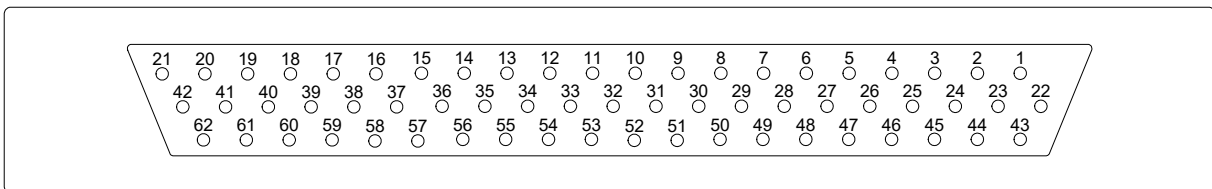

Outside View  
(Mating Connector)

2.5.2 Connector P2

Pin #		Name	Signal Type (dependent on maintenance page selection)
	16	<b>Inverter Exc.</b>	In <i>Inverter</i> Note: May be same or different than P1-22 inverter source. 26Vac Excitation for items on connector P2
1		<b>Shield Gnd</b>	
	31	<b>FMS 1A</b>	In <i>A429 (RS422) (RS232)</i> A side 429 + side 422 Ground side
	17	<b>FMS 1B</b>	In <i>A429 (RS422) (RS232)</i> B side 429 - side 422 Rx
2		<b>FMS 2A</b>	In <i>A429 (RS232)</i> A side 429 Ground Side
	32	<b>FMS 2B</b>	In <i>A429 (RS232)</i> B side 429 Rx
	18	<b>ILS Energize1 Discrete In HDG X Alternate</b>	In <i>Discrete A407</i> Discrete Open/Gnd or Open/+28Vdc Synchro X [Z grounded]
3		<b>NAV1A</b>	In <i>A429 A710</i> A side 429 Composite Video
	33	<b>NAV1B</b>	In <i>A429</i> B side 429
	19	<b>ILS Energize2 Discrete In HDG Y Alternate</b>	In <i>Discrete A407</i> Discrete Open/Gnd or Open/+28Vdc Synchro Y [Z grounded]
4		<b>ADF 2A TACAN 1A</b>	In <i>A429 A419 DC Sin A407</i> A side 429 A Side 419 (TACAN only) DC Sine (ADF only) Synchro X [Z grounded]
	34	<b>ADF 2B TACAN 1B</b>	In <i>A429 A419 DC Cos A407</i> B side 429 B Side 419 (TACAN only) DC Cosine (ADF only) Synchro Y [Z grounded]
	20	<b>ADF 2 DC Ref</b>	In <i>ADF Ref</i> ADF DC, Note: Not used when 429 or XYZ is data source.
5		<b>ADF 2 Valid</b>	In <i>Discrete Valid</i> ADF Discrete, Note: Not used when 429 is data source
	35	<b>NAV2A</b>	In <i>A429 A710</i> A side 429 Composite Video
	21	<b>NAV2B</b>	In <i>A429</i> B side 429

**P2 Connector (continued from previous page)**

Pin #		Name	Signal Type (dependent on maintenance page selection)
6		<b>DME 1 DATA</b>	In <i>A568</i> Analog <i>A429</i> DC+ A side 429
	36	<b>DME 1 CLK</b>	In <i>A568</i> Analog <i>A429</i> DC- B side 429
	22	<b>DME 1 SYNC</b>	In <i>A568</i>
7		<b>DME 1 Hold</b>	In <i>Discrete</i>
	37	<b>OBS Resolver DC Ref</b>	In <i>Resolver DC</i>
	23	<b>OBS Resolver H</b>	In <i>Resolver H</i>
8		<b>OBS Resolver X/Sin out</b>	Out Resolver Out
	38	<b>OBS Resolver Y/Cos out</b>	Out Resolver Out
	24	<b>Fluxgate Excitation</b>	In Fluxgate Excitation
9		<b>Fluxgate X</b>	In
	39	<b>Fluxgate Y</b>	In
	25	<b>Fluxgate Z (Gnd)</b>	In
10		<b>Hdg Crs/Datum Excitation</b>	In 3 <sup>rd</sup> inverter input used specifically if autopilot inverter is not inverter connected to P1-22 or is not 400Hz
	40	<b>Course Datum</b>	Out Locked to P1-22 or P2-10
	26	<b>Hdg Datum</b>	Out Locked to P1-22 or P2-10
11		<b>Hdg X Out</b>	Out Bootstrap, locked to inverter on <b><u>P1</u></b>

**P2 Connector (continued from previous page)**

Pin #		Name	Signal Type (dependent on maintenance page selection)
	41	<b>Hdg Y Out</b>	Out Bootstrap, locked to inverter on <b>P1</b>
	27	<b>FCS ILS Energize Out</b>	Out Active Low
12		<b>FCS Lat Flag+</b>	Out LL Out (gnd ref)
	42	<b>FCS Vert Flag+</b>	Out LL Out (gnd ref)
	28	<b>FCS Lat Dev+</b>	Out LL Out (gnd ref)
13		<b>FCS Vert Dev+</b>	Out LL Out (gnd ref)
	43	<b>FCS Lat Superflag Out</b>	Out Superflag Out
	29	<b>FCS Vert Superflag Out</b>	Out Superflag Out
14		<b>RS232-2 Out</b>	Out RS232
	44	<b>N/C</b>	
	30	<b>429-2A</b>	Out A429 A side 429
15		<b>429-2B</b>	Out A429 B side 429

Note 1: For XYZ inputs Z is signal ground P1-1. For XYZ Outputs Z is power ground.

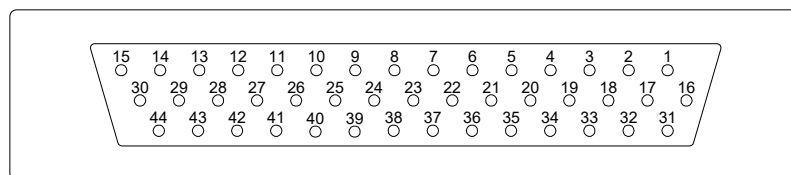

Outside View  
(Mating Connector)



2.5.3 Connector P3

Pin #	Name	Signal Type (dependent on maintenance page selection)
1	Aircraft Pwr	In Power +22 to +33Vdc
9	Aircraft Pwr	In Power
2	GPS OBS/HOLD or TACAN Relay Out	(Out) (Open Drain)
10	GPS APPR ARM or TACAN Relay Out	(Out) (Open Drain)
3	Aircraft Ground	In System Ground
11	Aircraft Ground	In System Ground
4	GPS1 Relay Sense / Selected	In Discrete
12	GPS2 Relay Sense	In Discrete
5	NAV2 Relay Sense	In Discrete
13	NVIS Ctrl/REV Control	In – Active Low Discrete
6	Analog DME Valid/ REV Control	In Discrete Valid
14	FCS BACK COURSE	Out (Open Drain)
7	GPS1 Relay	Out Open Drain
15	GPS2 Relay	Out Open Drain
8	NAV2 Relay	Out Open Drain

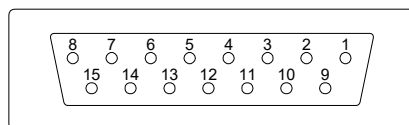

Outside View  
(Mating Connector)

#### 2.5.4 Configuration Module Connector

Accepts SN4500 Configuration Module.

The configuration module holds all installation data and is specific to the aircraft. If the SN4500 is swapped, re-using the configuration module will automatically reconfigure the new unit to the original aircraft configuration.

The SN4500 may be operated with or without a configuration module connected. If no configuration module is present the SN4500 will operate but the pilot will receive an advisory message.

2.5.5 Signal Characteristics Table

<b>Inputs</b>			
<b>Signal Type</b>	<b>Nom Range</b>	<b>Absolute Max <sup>Note 3</sup></b>	<b>Z (Ω – Power Off)</b>
A429	+/- 5Vdc	100Vdc	>100K
A568	0 / +10Vdc	100Vdc	>100K
RS232	+/- 10Vdc	100Vdc	>100K
RS422	+/- 5Vdc	100Vdc	>100K
A710 (ILS)	.5Vac rms +/- 20%	70Vac	>100K
A711 (VOR)	.5Vac rms +/- 20%	70Vac	>100K
A407	0 to 11.8Vac	70Vac	>100K
DC SIN/COS	+/- 20Vdc	100Vdc	>100K
A407 (AC Synchro)	11.8Vac rms +/- 20%	100Vdc	>100K
ADF_REF	10Vdc +/- 50%	60Vdc	>100K
Alt DC Coarse	0 to 15Vdc	100Vdc	>100K
Analog DME	0 to 8Vdc	75Vdc <sup>Note 5</sup>	180K
Discrete Valid (High)	>14.0Vdc <sup>Note 4</sup>	60Vdc	>500K
Discrete Valid (Low)	<3.5Vdc <sup>Note 4</sup>	40Vdc	>500K
Discrete (High)	>1.2Vdc	32Vdc	50K
Discrete (Low)	<8Vdc	32Vdc	50K
GS	+/- 225mv FS	60Vdc	>160K <sup>Note 2</sup>
GS Flag	Unflagged > 225mv	60Vdc	>160K <sup>Note 2</sup>
Inverter	26Vac rms	200Vac	>50K
Power	+22 to +33Vdc <sup>Note 1</sup>	7Adc	NA

<b>Outputs</b>			
<b>Signal Type</b>	<b>Nom Range</b>	<b>Absolute Max <sup>Note 3</sup></b>	<b>Z (Ω – Power Off)</b>
A429	+/- 5Vdc	70mAdc	2K (Minimum)
RS232	+/- 5Vdc	70mAdc	500 (Minimum)
A575	3.54 mA +/-1%	25mA	500
Open Drain	1Ω or High Impedance (over current protected)	250mAdc	>350K

Notes:

1. At +28Vdc, nominal current is 1.4Adc, 1 minute after start up.
2. Power On Load = 60.4K. For Glideslope there may need to be a 1K load somewhere else in the system to meet the receiver load requirements. Check installation instructions for the interfaced receiver.
3. Outputs are protected against shorts to ground. Shorts to power supply may cause damage to components.
4. Discrete inputs actively pulled to 27.5v through 30k ohms when selected 'active low' or actively pulled to 0v through 30k ohms when selected 'active high' in the maintenance pages. This ensures the input is in the 'inactive' state if an external connection fails. If interfacing to discrete signals which do not supply a "hard" 0v/27.5 volt transition, any input network may be used that ensures that the discrete input pin is not within 1.0v from its nominal threshold shown in the table either in the active or inactive state.

## 2.6 ARINC 429

### 2.6.1 ARINC 429 Serial Data Receivers Interfaces

The ARINC 419/429 serial data bus interface provides an information link between the SN4500 and peripheral avionics equipment. The bus conforms to 419/429 specifications for electrical characteristics, receiving, and transmission interval.

The SN4500 is capable of receiving the following low or high speed ARINC 419/429 NAV, ADF, TCAS, or DME inputs for processing and display as follows:

LABEL	DESCRIPTION
<b>ADF</b>	
162	ADF Bearing
<b>Gyro/ AHRS</b>	
155	Maintenance Words (Sandel SG102 Only)
270	AHRS Status Information (when available)
320	Magnetic Heading
324	Pitch
325	Roll
332	Lateral Acceleration
350	Maintenance Words (Sandel SG102 Only)
351	Maintenance Words (Sandel SG102 Only)
352	Maintenance Words (Sandel SG102 Only)
353	Maintenance Words (Sandel SG102 Only)
354	Maintenance Words (Sandel SG102 Only)
<b>TCAS</b>	
013	Control Word for TCAS/Mode S
015	Altitude Select Limits for TCAS / Mode S
016	Control Word for TCAS/Mode S
130	Intruder Range
131	Intruder Altitude
132	Intruder Bearing
203	Altitude (1013.25 mB)
204	Baro Corrected Altitude
271	TCAS III N/A
320	Magnetic Heading
371	General Aviation Equipment Identifier
377	Equipment Identification
357	Request To Send (RTS) / End Transmission (ETX)
<b>NAV</b>	
034	VOR/ILS Frequency
173	Localizer Deviation
174	Glideslope Deviation
222	VOR Omnibearing
371	General Aviation Equipment Identifier
<b>TACAN</b>	
201	TACAN Distance
202	TACAN Distance
222	TACAN Bearing

<b>LABEL</b>	<b>DESCRIPTION</b>
246	TACAN Station ID (Characters 1-2)
247	TACAN Station ID (Characters 3-4)
362	TACAN Range Rate
<b>DME</b>	
035	DME Frequency
202	DME Distance
<b>GPS/FMS</b>	
076	GNSSS Altitude
100	Selected Course #1
114	Desired Track
115	Waypoint Bearing
116	Cross Track Distance
117	Vertical Deviation
121	Horizontal Command (Roll Steering Commands)
125	Universal Time Coordinated (UTC)
147	Magnetic Variation
150	Time
251	Distance To Go
260	Date
261	GPS Discrete Word (GAMA)
266	FMC Nav Mode
275	Status Word (GAMA)
310	Present Position – Latitude
311	Present Position – Longitude
312	Ground Speed
313	Track Angle – True
315	Not Used
316	Not Used
326	Lateral Scale-Factor
327	Vertical Scale-Factor
377	Equipment Identification
303	Message Length / Type / Num
075	Active Waypoint From / To Data
074	Flight Plan Header
275	Status Word (GAMA)
113	Message Checksum
300	Station Type, Class
304	Message Characters 1-3
305	Message Characters 4-6
306	Waypoint Latitude
307	Waypoint Longitude
340	L/R Procedure Turn Azimuth
335	L/R Holding Pattern Azimuth
330	Arc Inbound Course
331	Arc Radius
332	Arc Change Angle

2.6.2 ARINC 429 Serial Transmitter Interfaces

The SN4500 is capable of transmitting the following low or high speed ARINC 429 data:

LABEL	DESCRIPTION
100G	Selected Course (Using extended SDI)
320	Magnetic Heading

## 3 Installation

### 3.1 General

This section provides general suggestions and information to consider before installing the SN4500 including interconnect diagrams, mounting dimensions and information pertaining to installation. Close adherence to these suggestions will assure optimum performance.

#### 3.1.1 Unpacking and Inspecting Equipment

Exercise extreme care when unpacking the equipment. Make a visual inspection of the unit for evidence of damage incurred during shipment. If a claim for damage is to be made, save the shipping container to substantiate the claim. The claim should be promptly filed with the carrier. It would be advisable to retain the container and packaging material after all equipment has been removed in the event that equipment storage or reshipment should become necessary.

### 3.2 Installation Considerations

#### 3.2.1 General Considerations

The SN4500 should be installed in accordance with standards established by the customer's installing agency, and existing conditions as to unit location and type of installation. However, the following considerations should be heeded before installing the SN4500. Close adherence to these considerations will assure a more satisfactory performance from the equipment. The installing agency will supply and fabricate all external cables. The required connectors and associated hardware are supplied by Nighthawk Flight Systems, Inc. .

#### 3.2.2 Cooling Considerations

The SN4500 contains its own ventilation fan for internal component cooling and therefore, does not require a forced air cooling system. Any questions concerning cooling can be verified in the post-installation checkout by monitoring the SN4500 Internal temperature on the System maintenance page.

#### 3.2.3 Mechanical Installation Considerations

The SN4500 installation should conform to customer requirements and airworthiness standards affecting the location and type of installation. §25.1321(a) stipulates that: "Each flight, navigation, and power plant instrument for use by any pilot must be plainly visible to him from his station with the minimum practicable deviation from his normal position and line of vision when he is looking forward along the flight path."

§ 25.1321(b) stipulates: "The flight instruments required by §25.1303 must be grouped on the instrument panel and centered as nearly as practicable about the vertical plane of the pilot's forward vision." In addition - §25.1321(b)(4) states: "The instrument that most effectively indicates direction of flight must be adjacent to and directly below the instrument in the top center position." Similar regulations apply to FAR Part 29 Transport Category Rotorcraft and to Part 23 Small Airplanes.

Refer to Nighthawk Flight Systems, Inc., Drawing No. 82009 titled, "Layout – SN4500 Installation" for specific assembly and mounting instructions.



### 3.2.4 Electrical Installation Considerations

Connections and functions of the SN4500 are described in this section. Refer to the SN4500 Interconnect Wiring Diagrams for detailed wiring information and appropriate notes. Refer to the Functional Pinout Descriptions for explanations of pin functions.

- A. The installing agency will supply and fabricate all wiring harnesses. The length and routing of wires must be carefully measured and planned before the actual installation is attempted. Avoid sharp bends in the harness or locating the harness near aircraft controls. Observe all recommended wire sizes and types and subscribe to appropriate FAR Parts 23, 25, 27, and 29, as well as AC 43.13-1() and -2().
- B. The use of MIL-C-27500 shielded wire and MIL-W-22759 single conductor wire is recommended. The use of ferrules or grounding blocks for signal ground and digital ground returns is satisfactory, however, each ground return must be electrically separated.
- C. When an existing installation of a navigation source selection relay unit is installed to provide mode control switching and annunciation for a GPS or other long-range navigation system, the SN4500 may not perform these functions simultaneously. This does not preclude the SN4500 from annunciating such mode control functions.
- D. In order to ensure optimum performance the SN4500 and associated wiring must be kept at least a minimum of three feet from high noise sources and not routed with cables from high power sources.
- E. Prior to installing the SN4500, a point-to-point continuity check of the wiring harness should be accomplished to verify proper wiring. See **FUNCTIONAL GROUND TEST PROCEDURES/REPORT** in the appendix for verification of this step and other checks.
- F. The Functional Pinout Descriptions on the following pages will assist you in determining installation requirements. **Adhere to all notes within these descriptions and on installation wiring diagrams.**
- G. **Special caution** must be taken to observe 30 Hz OBS resolver connections in order to prevent possible damage to the installed VOR/localizer converter. See Installation Wiring Diagrams and the MAINTENANCE MENU, Configuration Instructions for notes pertaining to these considerations.
- H. **Ground Bonding.** In order to assure installation characteristics match the DO-160 RF and Lightning test conditions, ensure that two ground wires of at least the recommended size are installed in accordance with the installation drawings and these wires are connected to a bonded aircraft ground. Ensure that shielded wiring is used to the Flux Gate (if installed), Gyro Reference, and Gyro XYZ (if installed).
- I. **Power Wiring.** To assure that the SN4500 will operate properly down to its rated minimum input voltage of 22Vdc, ensure that two power wires of at least the

recommended size are connected from the EHSI circuit breaker to the SN4500 in accordance with the installation drawings.

### 3.3 Signal Details

The following information is in the same order as the summary pin description list in the prior section.

#### 3.3.1 Connector P-1 Pinout Description

**P1-1: Signal Ground Return Input**

This common Signal Ground Return is used for P1 analog signal grounds such as the Z lead of synchros, and analog signal shield grounds. See the installation wiring diagrams for details. Do not use this pin to connect digital signal ground return shields or use this for power ground return.

**P1-22: Primary AC Excitation Input for P1 inputs**

Connection to this pin is required only if functions of ARINC 407 synchro or 400Hz AC sine and cosine inputs are used on P1. NOTE: This is also the reference for synchro referenced *outputs* on the opposite connector P2. The input requirements are 26Vac nominal 400Hz. Input frequency is 560 Hz. Maximum and 240 Hz. minimum. Input impedance is 220KΩ. 24 AWG shielded wire is recommended for this function.

**P1-43: TCAS 429 A**

**P1-23: TCAS 429 B**

Optional ARINC 429 input for traffic.

**P1-2: Data link A**

**P1-44: Data link B**

Optional input for ADS-B In serial data..

**P1-3: Hdg X; Hdg 429A; DG Stepper A Input**

**P1-45: Hdg Y; Hdg 429B; DG Stepper C Input**

Master HDG inputs.

For XYZ type directional gyro, ground the Z leg to signal ground P1-1. This input is referenced to the 26Vac/400Hz reference on P1-22. This function is selected on the Compass maintenance page.

Stepper connections are used exclusively for connections to the Bendix/King KG-102 or Mid-Continent series Directional Gyro when selected in the Compass maintenance page. For slaved operation see fluxgate descriptions. 24 AWG twisted shielded pair wire is recommended for this connection.

**P1-25: Hdg Valid Input**

Connect to the (DG) valid output if available. Not used for 429 sources. Selection of the logic level of this pin is in the Compass maintenance page.

**P1-4: ADF-1 AC-X or DC-SIN Input / TACAN 2 429/419 A**

**P1-46: ADF-1 AC-Y or DC-COS Input / TACAN 2 429/419 B**

Inputs from ADF-1 Receiver. Selection of AC/DC operation is on the ADF maintenance page. For DC use P1-26 as the DC reference input. For AC inputs Z is grounded. 24 AWG twisted shielded pair wire is recommended for these functions.

**P1-26 ADF-1 DC Ref**

Used when DC SIN/COS inputs are used

**P1-5 ADF-1 Valid**

Discrete ADF Valid input used if available.

**P1-47: WX500 Ground**

**P1-27: WX500 RS232**

Connection to WX-500 Stormscope. Use 24AWG twisted pair.

**P1-6: Glideslope +FLAG**

**P1-48: Glideslope –FLAG**

Low level GS receiver flag inputs. Superflags can be supported with a resistor, see the installation drawings.

**P1-7: Glideslope +UP Deviation Input**

**P1-28: Glideslope +DOWN Deviation Input**

GS deviation input. Two-dot deflection is  $\pm 150$  mV<sub>dc</sub>. 24 AWG twisted shielded pair wire is recommended for these functions.

**P1-49: VOR-LOC +FLAG**

**P1-29: VOR-LOC –FLAG**

Used when an external NAV converter or analog output GPS is used. Differential Low level NAV Flag inputs. Superflags are supported with a resistor, see the installation drawings. Flag out of view requires greater than 215 mV<sub>dc</sub> on +FLAG with respect to –FLAG input. 24 AWG twisted shielded pair wire is recommended for these functions.

**P1-8: VOR-LOC +RIGHT Deviation Input**

**P1-50: VOR-LOC +LEFT Deviation Input**

Used when an external NAV converter or analog output GPS is used. Analog lateral deviation from the VHF navigation receiver or long-range navigation receiver +LEFT and +RIGHT deviation outputs. Two-dot deflection is  $\pm 150$  mV<sub>dc</sub>. 24 AWG twisted shielded pair wire is recommended for these functions.

**P1-30: VOR +TO Pointer Input**

**P1-9: VOR +FROM Pointer Input**

Used when an external NAV converter or analog output GPS is used. Differential input supports VHF NAV or long-range navigation +TO pointer and +FROM pointer outputs. In-view is greater than 40 mV<sub>dc</sub> (to) and –40mV<sub>dc</sub> (from). 24 AWG twisted shielded pair wire is recommended functions.

**P1-51: DME 2 CLK; DME 2 429A**

**P1-31: DME 2 Data; DME 2 429B**

**P1-10: DME 2 Sync**

ARINC 568 Sync or King Clk/Data/Sync (DME REQ) signal input. NOTE: This is DME 2.

**P1-52: DME 2 Hold; DME 1/2**

Discrete HOLD input signal for on-screen annunciator

**P1-32: Differential Resolver SIN Input**

**P1-11: Differential Resolver COS Input**

**P1-53: Inner Marker Beacon Input**

**P1-33: Middle Marker Beacon Input**

**P1-12: Outer Marker Beacon Input**

Marker beacon receiver inputs. Normally connected to the external lamp drivers on the marker beacon receiver, see the installation drawings. Most marker beacon receivers use “DC” ground referenced outputs driven by transistor drivers. All such receivers are compatible as shown on the installation drawings. Some very old designs may use transformer outputs which are AC coupled. These may not be compatible.

**P1-54: ARINC1 429-A Output**

**P1-34: ARINC1 429-B Output**

Low or high speed ARINC 429 output, spare. (Future use.)

**P1-13: Ch1 RS-232 TX Output**

RS-232 serial data outputs. TXD-2 is used to support WX-500 Stormscope®. 24 AWG shielded wire is required for each of these functions.

**P1-55: WPT Annunciator input**

**P1-35: MSG Annunciator input**

**P1-14: ACT (Approach Active) Annunciator Input**

**P1-56: ARM (Approach Arm) Annunciator Input**

Active-low inputs for GPS/LRN on-screen annunciators.

**P1-15: OBS-/LEG, HLD-/AUTO or PAR TRK- Annunciator Input**

For selected GPS-1 receiver with OBS/LEG mode (or HOLD/AUTO), this input when low senses and annunciates OBS or HOLD on the SN4500 display and changes the mode of the course pointer from auto-slew to manual control. Otherwise, this is used as a PAR TRK input for other types of receivers, based on the selection in the LNAV maintenance page.

- P1-58: ILS Energize 1 Alternate**
- P1-38: ILS Energize 2 Alternate**
- P1-19: Remote Course Control X Input**
- P1-61: Remote Course Control Y Input**
- P1-20: Remote Heading Control X Input**
- P1-62: Remote Heading Control Y Input**
- P1-21: Remote Dimmer Control Input**

### 3.3.2 Connector P-2 Pinout Descriptions

#### **P2-1: Signal Ground Return Input**

This common Signal Ground Return is used for P2 analog signal grounds such as the Z lead of synchros, and analog signal shield grounds. See the installation wiring diagrams for details. Do not use this pin to connect digital signal ground return shields or use this for power ground return.

#### **P2-16: AC Excitation Input for P2 inputs**

Connection to this pin is required only if functions of ARINC 407 synchro or 400Hz AC sine and cosine inputs on P2. It does NOT apply to **outputs** on P2. The input requirements are 26Vac nominal 400Hz. Input frequency is 560 Hz. Maximum and 240 Hz. minimum. Input impedance is 220K $\Omega$ . 24 AWG shielded wire is recommended for this function.

#### **P2-31: GPS1/FMS 1 429A/422+/232 Gnd**

#### **P2-17: GPS1/FMS 1 429B/422-/232 Signal**

Main input from GPS/FMS 1.

#### **P2-2: GPS2/FMS 2 429A/422+/232 Gnd**

#### **P2-32: GPS2/FMS 2 429B/422-/232 Signal**

Main input from GPS/FMS 2.

#### **P2-18: VHF Nav-1 ILS Energize Input or Heading Alternate X input**

This pin controls the Vertical Deviation Bar when selected to NAV1. These signals also control the ILS Lockout logic so the SN4500 can sense when a GPS receiver is inappropriately selected as the primary NAV source when ILS Lockout is not disabled on the NAV maintenance page. Connections to these pins are from the respective VHF navigation receiver and optionally by the GPS receiver. The logic level of these inputs is selected on the NAV maintenance page, and is normally active-low.

#### **P2-3: VHF NAV1 429A/Composite**

#### **P2-33: VHF NAV1 429B**

Primary 429 input from VHF NAV1, or composite input from analog receiver for VOR bearing pointer. Composite is normally .5v VOR / .33v LOC. For 3V inputs a series resistor is required, see the installation drawings. When using the composite input for LOC deviation, the calibration procedure found in section 7.1.5 must be followed for each specific LOC input. 24 AWG shielded wire is recommended for these connections. Note: When using the composite signal for the localizer deviation input, the calibration

procedure found in section 7.1.5 must be performed after the installation prior to release for flight.

**P2-4: ADF-2 AC-X or AC/DC-SIN Input / TACAN 1 429/419 A**

**P2-34: ADF-2 AC-Y or AC/DC-COS Input / TACAN 1 429/419 B**

Inputs from ADF2 Receiver. Selection of AC/DC operation is on the ADF maintenance page. For DC use P2-20 as the DC reference input. For AC inputs Z is grounded. 24 AWG twisted shielded pair wire is recommended for these functions.

**P2-20: ADF2 DC Ref**

Used when DC Sin/Cos inputs are used.

**P2-5: ADF2 Valid**

Discrete ADF Valid input used if available.

**P2-19: VHF Nav2 ILS Energize Input or Heading Alternate Y input**

Control the enabling of the Vertical Deviation Bar when NAV2 selected

**P2-35: VHF NAV2 429A/Composite**

**P2-21: VHF NAV2 429B**

Primary 429 input from VHF NAV2, or composite input from analog receiver for VOR bearing pointer. Composite is normally .5v VOR / .33v LOC. For 3V inputs a series resistor is required, see the installation drawings. When using the composite input for LOC deviation, the calibration procedure found in section 7.1.5 must be followed for each specific LOC input. 24 AWG shielded wire is recommended for these connections. Note: When using the composite signal for the localizer deviation input, the calibration procedure found in section 7.1.5 must be performed after the installation prior to release for flight.

**P2-6: DME1 Data, Analog DME DC+, DME1 429A**

**P2-36: DME1 CLK, Analog DME DC-, DME1 429B**

**P2-22: DME1 Sync**

**P2-7: DME1 Hold**

Serial data inputs for either ARINC 429 / 568 serial protocols to support ARINC DME's as selected within the DME Maintenance page (Low speed only), Bendix/King DME's using King Serial Digital protocol. See the installation drawings. 24 AWG twisted shielded triple conductor is required for these functions. Note: This is DME1.

Analog DME input (40mV/mile) may also be used.

**P2-37: OBS Resolver DC ref Input**

**P2-23: OBS Resolver H Input**

**P2-8: OBS Resolver SIN Output**

**P2-38: OBS Resolver COS Output**

OBS resolver connections for NAV or GPS receivers. The input frequency range is 20Hz to 500Hz, and calibration is done on the NAV maintenance page. The resolver is electrically zeroed at zero degrees plus the calibration value in the NAV maintenance page. For normal use this calibration value will be -60 degrees (equaling 300 degrees

electrical zero). This is the factory default. A different calibration value setting is used for each possible NAV source selectable on the SN4500. 24 AWG twisted shielded pair conductor is recommended for these functions. Please see the warnings on the installation drawings concerning DC REF, which must not be inadvertently grounded..

**P2-24: Flux Gate Excitation Input**

This connection is made to the 400 Hz AC flux gate excitation source voltage. A 24 AWG shielded wire is recommended for this function. Note: the phase of this excitation voltage is not required to be the same as that supplied to the Primary AC Excitation input on P1 or P2.

**P2-9: Flux Gate X Input**

**P2-39 Flux Gate Y Input**

**P2-25: Flux Gate Z Input**

Referenced to P2-24 Excitation input. Connections to these pins are made directly from the heading system flux gate if internal slaving is selected on the compass maintenance page. If a Bendix/King KI-525 PNI or Rockwell/Collins 331A-3( ) HSI is being removed, the respective slaving accessory, should be bypassed. See the installation drawings for details. 24 AWG twisted shielded triple conductor is recommended for these signals.

**P2-10: HDG/CRS Datum Excitation**

This is a ground referenced 400-5Khz excitation input for the HDG Datum and CRS Datum outputs only. This input is used if AC Course/HDG Datum is required.

**P2-40: Course Datum Output**

**P2-26: Heading Datum Output**

These functions are either AC or DC Course Datum and Heading Datum for the flight control system. If AC signals, the excitation reference is P2-10. Selection of gain and direction of rotation are accomplished on the FCS maintenance page. 24 AWG single conductor shielded wire is recommended for each of these functions.

**P2-11: HDG Bootstrap X out**

**P2-41: HDG Bootstrap Y out**

Z Ground. NOTE: Referenced to P1-22. This function may be used to provide “bootstrap” output to an RMI or other directional instrument in the form of ARINC 407 synchro 24 AWG twisted shielded pair wire is recommended for these functions. Drive only electronic loads with this output – limited to 60ma max.

**P2-27: FCS ILS Energize Out**

Active-low open drain output to FCS when selected navigation source vertical deviation is enabled.

**P2-12: FCS Lateral Flag Output+**

Low Level flag output derived from selected NAV source, referenced to Ground. Connect corresponding ‘-‘ input to P2-1 (Gnd)

**P2-42: FCS Vertical Flag Output+**



Low Level flag output derived from selected NAV source, referenced to Ground. Connect corresponding ‘-‘ input to P2-1 (Gnd)

**P2-28: FCS Lateral Deviation Output +Right**

LL lateral +deviation from selected NAV source. Connect corresponding ‘-‘ deviation input to P2-1 (Gnd)

**P2-13: FCS Vertical Deviation Output +**

LL vertical +deviation from selected NAV source. Connect corresponding ‘-‘ deviation input to P2-1 (Gnd)

**P2-43: FCS Lateral Superflag Output**

Superflag output derived from selected NAV source.

**P2-29: FCS Vertical Superflag Output**

Superflag output derived from selected NAV source.

**P2-14: RS-232 TX Output2**

RS-232 serial FIS-B data link output (Software Rev 3.0 and above).

**P2-30: ARINC2 429-A Output**

**P2-15: ARINC2 429-B Output**

Low or high speed ARINC 429 output which transmits selected course and selected heading for ARINC 429 Long Range NAV receivers. 24 AWG twisted shielded pair wire is required for these functions.

### 3.3.3 Connector P-3 Pinout Descriptions

**P3-1 &**

**P3-9: Display Primary Power Input**

(22-33Vdc) Connection to both pins is required using two 20AWG wires and a 5 ampere circuit breaker. Nominal power required is 40 watts. Connection to the avionics bus is recommended to reduce voltage fluctuations during engine start.

**P3-3 &**

**P3-11: Display Power Return Input**

Pins 3 and 11 are the aircraft ground input connections. Connection to both pins is required using two 20 AWG wires. Either pin should also be used for the digital signal ground (shields) return, as required. The number of shields will vary depending upon the functions wired to Connector P3.

**P3-2: GPS OBS- or HOLD- Command Discrete Output or TACAN Relay Out**

Open Drain active-low output used to operate the OBS function of Bendix/King KLN-90 GPS receivers or the HOLD function of the II Morrow and Garmin GPS receivers. Accessible during normal use from the pilots GPS MODE soft key. Can also be used to operate a switching relay, or external annunciator whenever a TACAN is selected by

the NAV pushbutton. The TACAN receiver(s) are configured on the NAV maintenance pages.

**P3-4: GPS1 Relay Sense / GPS SELECTED Input**

This input is used when the SN4500 is set up for slave mode so an *external* GPS switch can be used to switch to an external GPS receiver. Causes proper mode switching and annunciation on the SN4500 display. This input is active only when enabled in the OBS / RELAY / CDI maintenance page 10.

**P3-5: NAV2 Relay Sense**

Feedback from NAV2 relay, if used. When replacing a SN3308 with the SN4500, see configuration page 7-14.

**P3-6: Analog DME Valid / REV CNTRL**

Discrete input for Analog DME valid or Reversionary Display On/Off control.

**P3-7: GPS1 Switching Relay Discrete Output**

Can be used to operate a switching relay whenever GPS1 (or Loran1) is selected by the NAV pushbutton. The receiver type is selected on the LNAV1 maintenance page.

**P3-8: VHF NAV2 Switching Relay Discrete Output**

Can be used to operate a switching relay whenever VHF NAV2 is selected by the NAV pushbutton. VHF NAV2 is enabled on the NAV2 maintenance page.

**P3-10: GPS APPR ARM Discrete Output or TACAN Relay Out**

Open Drain active-low output used to select APPR ARM mode of the external GPS receiver. Accessible during normal use from the pilots NAV menu operation. Can also be used to operate a switching relay, or external annunciator whenever a TACAN is selected by the NAV pushbutton. The TACAN receiver(s) are configured on the NAV maintenance pages.

**P3-12: GPS2 Relay Sense**

Feedback from GPS2 relay, if used.

**P3-13 NVIS Ctrl or REV Ctrl**

For NVIS capable units NVIS mode is enabled by a closure to ground through an external toggle switch or maintained pushbutton switch. NVIS mode is annunciated onscreen so an external annunciator is not required.

The input will always pull up to the de-activated state when disconnected.

Can also be used for Reversionary Display ON/OFF control.

**P3-14: AFCS Back Course Discrete Output**

Open Drain. Used to feed the back course sensing input of an AFCS. When the Course Select rotates either direction passing 90° clockwise or counterclockwise from the lubber line of the SN4500 will generate an open-drain closure. An external relay may be required to make this signal active-high.

**P3-15: GPS2 Switching Relay Discrete Output**

Can be used to operate a switching relay whenever GPS2 (or Loran2) is selected by the NAV pushbutton. The receiver type is selected on the LNAV-2 maintenance page.

## 4 Setup Procedures

### 4.1 General

Setup procedures for the SN4500 are described along with the Maintenance Menu below. The Maintenance Menu is accessed and addressed through the use of pushbuttons and the Selected Heading knob. No external connector pin programming is required.

### 4.2 Accessing the Maintenance Menus

To access the Maintenance Menus perform the following operations:

- A. Prior to applying power to the SN4500, depress and hold the [AUX] and the [MEM] pushbuttons, then apply power to the unit. Continue to hold until the first maintenance menu appears. This protocol insures that maintenance menus cannot be called up accidentally during flight.
- B. Once the Maintenance Menu is entered, press the [NEXT] or [PREV] softkeys to cycle the MAINTENANCE MENU pages. Use the UP/DOWN arrow keys for selections, and rotate the right knob to adjust and select. On some menus additional soft key legends will appear as prompts.
- C. Escape the maintenance menus by pressing and holding the CRS knob (left knob). This will allow normal operation of the unit to test the effects of settings. Re-enter the maintenance pages pressing and holding the CRS knob (left knob).
- D. To disable maintenance menu operation, power down and restart normally. All configured items are stored in non-volatile memory.

### 4.3 Equipment/Configuration Selection

The choices of compatible equipment contained in the SN4500 menus are listed in the Appendix. For types not listed, consult the factory.

### 4.4 Configuration Module

The Configuration Module (CM) stores installation configurations. The physical Configuration Module is directly mounted to the rear of the instrument. Configuration module can be used when replacing an existing SN4500. Data stored in the configuration module can be copied directly to the replacement unit.

## 4.5 Configuration Module Status Page



“**CONFIG MODULE STATUS**” page may appear during initial turn on and programming of a new or replacement unit. This page will only appear again if there is a mismatch between the configuration information saved in the Configuration Module and the SN4500. The mismatch identified with the configuration information is shown at the top of this page, along with the actions that may be taken.

The options displayed on the “**CONFIG MODULE STATUS**” page are as follows.

### “**DISABLE CM**” (CM)

When this option is selected no stored data will be read from or written to the Configuration Module. Selecting “Disable CM” will allow the installer to go directly to the Maintenance Index page 1.

Note “**CM**” will appear in the upper right corner to indicate that the configuration module is not operational.

### “**SN4500 TO CM**”:

The current SN4500 configuration is written to the configuration module and stored.

**NOTE:** When selecting this option SN4500 configuration data will be written TO the configuration module and overwrite any existing configuration data in the Configuration Module.

### “**CM TO SN4500**”:

Stored Configuration Module data is written to the SN4500.

**NOTE:** When selecting this option data FROM the configuration module will overwrite any existing configuration data in the SN4500. The configuration module is unaffected.

As part of the configuration, an aircraft identifier (Tail Number) should be entered on the systems settings page.

If installing a replacement SN4500 (using the existing Configuration Module):

To clear the SN4500 / CM MISMATCH message, perform the following steps in this order:

- 1) Select CM to SN4500 to write stored Configuration Module data to the SN4500.
- 2) Select SN4500 to CM.

## 5 Operating Details

For an explanation of the operating controls of the SN4500, refer to the Pilot's Guide for the SN4500, Nighthawk Flight Systems, Inc. P/N 82009-PG, and to the Airplane Flight Manual Supplement.

## 6 Instructions For Continued Airworthiness

The following is a summary of the Instructions for Continued Airworthiness prepared under the guidelines of FAA Advisory Circulars 23.1309-1() and 25.1309-1() which identifies potential failure modes of the Nighthawk Flight Systems, Inc. Model SN4500 Navigation Display. The assumption made is that all functions of the SN4500 will be used in an essential (primary) navigation function.

No scheduled maintenance required.



**7 Appendix A: Post-Installation Procedures**

After all wiring has been verified and the SN4500 has been installed into the panel, the maintenance pages must be accessed to properly configure the SN4500 for the installed equipment. Prior to applying power to the SN4500, depress and hold the [AUX] and the [MEM] keys, and then apply power to the unit. Continue to hold until the first maintenance menu appears. This protocol insures that maintenance menus cannot be called up accidentally during flight.

Once the Maintenance Menu is entered, press the [NEXT] or [PREV] softkeys to cycle the MAINTENANCE MENU pages. Use the UP/DOWN arrow keys for selections and rotate the right knob to adjust and select. On some menus additional soft key legends will appear as prompts.

Escape the maintenance menus by pressing and holding the CRS knob. This will allow normal operation of the unit to test the effects of settings. Re-enter the maintenance pages pressing and holding the CRS knob.

To disable maintenance menu operation, power down and restart normally. All configured items will be stored in non-volatile memory.

NOTE: When configuring ARINC 429 inputs, select '429' for low-speed and '429H' for high-speed.

Each maintenance page, the options for each, and a brief description of each option are detailed below:

## 7.1.1 Page 1: INDEX



The Maintenance Index page is a multiple-choice list that provides an index of all other maintenance pages and allows the operator to jump to a particular page. First scroll the Cursor to point to the desired maintenance page listing using the [UP] Soft key or [DOWN] Soft key. The [SELECT] Soft key is then pressed to jump to this page. Once in the maintenance pages, press the [OPER] Soft key to return to the Maintenance Index page. The [PREV] or [NEXT] Soft keys may also be used to reach a particular maintenance page sequentially.

The [MODE] Soft key is used to toggle the SN4500 between READ and EDIT mode. Note: The SN4500 must be in EDIT mode to make configuration changes on the following maintenance pages.

## 7.1.2 Page 2: SYSTEM



The System page provides information that identifies the unit and the unit's hardware and software.

Configuration Field	Options	Comment
Rmt Switch Annum	NO YES	Set to yes to allow SN4500 to control GPS switch inputs (LEG/OBS switching, APPR ARM etc.) through Pilot's Menu. Available options will depend on the model of GPS selected on the GPS maintenance page.
TCN Discr Out	None P3-2 P3-10	Selects which pin connector pin is assigned to TACAN Relay Out Signal.
Install Position	PLT ONLY PLT DUAL COP DUAL	Set to adjust color of on-side/cross-side NAV information.
Hdg Bug Color	ORANGE WHITE	Selects desired heading bug color.
Loc/GS pointer	BAR TRIANGLE	Selects style of Loc/GS pointer.
Center VDI Ena	ENABLE DISABLE	Set to enable or disable display of the inner Vertical Deviation Indicator.
Aircraft Ident	7 characters	Enter aircraft identification for reference.
Data recording	ENABLE DISABLE	Set ENABLE to allow data recording.

## 7.1.3 Page 3: COMPASS SYSTEM



The Compass System page configures the gyro and fluxgate (if applicable) to the SN4500.

Configuration Field	Options	Comment
HEADING	NONE 429 429H XYZ XYZ- MID CONT KG102 XYZ INV 2 XYZ- INV 2	Selects the gyro input to the SN4500.        Alternate inverter selection Alternate inverter selection
VALID	NONE HIGH LOW	Not shown if 429 or 429H is selected for heading.
FLXGATE	NONE KMT112 COLLINS HONEYWELL STEC 6446	Selects model of fluxgate input when slaving is performed internally.
QUAD	0.0° 90.0° 180.0° 270.0°	Set automatically when fluxgate is selected.

Configuration Field	Options	Comment
PEAK	0 – 7	Set automatically when fluxgate is selected
CAL N CAL E CAL W CAL S	-25.0° - 25.0°	Calibration settings for fluxgate input. See below.

### Compass Calibration (Applies to installations using a fluxgate input)

When a flux gate is first selected the quadrant and peaking adjustments will be automatically set.

The magnetic heading shown in the value field at the top of the page should be within +/-20° of the aircraft's wet compass reading. The magnetic heading reading should also increase and decrease as appropriate when the aircraft is turned. If this is not the case, the following troubleshooting procedure can be used to diagnose fluxgate problems:

- a) Align the aircraft to north. Set the CAL settings to 0.0°. Adjust the quadrant setting until the magnetic heading is +/-20° of north. If it is not possible to come within +/-20° of north then the XYZ connections on the fluxgate may actually be 'YZX' or 'ZXY'. Take all three wires off the fluxgate and move them one terminal 'clockwise' and retest as above. It may be necessary to repeat this step. Once the magnetic heading reads within +/-20° of north then the correct Z leg has been identified and should not be changed

Note: When installing to existing wiring, ensure that the fluxgate center tap that exists on some Honeywell/Sperry and Collins fluxgates is not connected.

- b) Ensure that the compass card rotation is correct by observing that the magnetic heading reading increases/decreases properly as the aircraft is turned. Reverse the XY inputs from the fluxgate to correct for reverse rotation if necessary.

Compass calibration is completed by aligning the aircraft at each cardinal heading and adjusting the corresponding calibration value until the magnetic heading reading observed on the compass maintenance page, matches the actual aircraft heading. After the four cardinal points have been adjusted and verified, a final check of the systems should be done by power cycling the SN4500 into normal mode and ensuring the compass rose is correct for each cardinal heading.

NOTE: Changes to the compass calibration settings may take up to two minutes to take effect when observing the compass card in normal operational mode. Therefore it is recommended to make these calibration adjustments on the compass maintenance page where the compass readings are instantaneous and not affected by the slaving logic in the SN4500.

### Reversionary Attitude Configuration (ARINC 429 Low/High speed only)

When the HEADING source is configured as ARINC 429, an optional Reversionary Attitude Mode is available for activation via a valid key entry. Once configured and valid, P3-pin 6 or pin 13 input discrete connected to an external switch controls the switching between HSI Mode and Reversionary Attitude Mode.



Configuration Field	Options	Comment
ATT Key	xxxxxxxxxxx	11 – char activation key for Reversionary Attitude Feature
ATT Pin	NONE ACTIVE L (P3-06) ACTIVE L (P3-13)	Enables the pin used for Reversionary Attitude discrete input. Select ACTIVE L such that either P3-06 or P3-13 is displayed in the PINS field.
PTCH CAL	d.dd	Pitch Adjustment of Reversionary Attitude display +/- 5.00

**ARHS Status Label 270 Configuration (Software A2.08 and above)**

When the HEADING source is configured as ARINC 429/429H, an additional field to select the Ahrs Status Label 270 definition is available.

Configuration Field	Options	Comment
Ahrs 270	SG102 LCR100-1000 LISA-200	See below for description of the bit definition for each option.

**AHRS 270 Label Selection: SG102 (Default)**

Bit	Definition	Bit = 1	Bit = 0
11	AHRS Alignment	Aligning	Normal
14	Heading Switch	Slaved Mode	DG Mode
15	Attitude	Invalid	Valid

**AHRS 270 Label Selection: LCR100-1000**

Bit	Definition	Bit = 1	Bit = 0
11	AHRS Alignment	Aligning	Normal
12	ATT/NAV Mode	ATT Mode	NAV Mode
14	Heading Switch	Slaved Mode	DG Mode
15	Attitude	Invalid	Valid

**AHRS 270 Label Selection: LISA-200**

Bit	Definition	Bit = 1	Bit = 0
11	AHRS Alignment	Aligning	Normal
12	FES	FES Active	FES Inactive
13	Mode Bits	Operating Mode Below	
14	Mode Bits		
15	Mode Bits		
16	Mode Bits		
19	AHRS GO/NOGO	Fail	Go

**Bit 16**

(MSB)	Bit 15	Bit 14	Bit 13	LISA-200 Operating Mode
0	1	1	0	STBY
0	0	0	0	SLAVE
0	1	0	0	DG
0	0	1	0	COMPASS
1	0	0	0	COMPASS CALIBRATION
0	0	0	1	SW HARMONIZATION

7.1.4 Page 4: ADF/TACAN/ MKR



The ADF/TACAN/MKR page allows the selection for ADF1, ADF2, TACAN and Marker Beacon sources.

Configuration Field	Options	Comment
ADF1	NONE 429 429H XYZ XYZ- S/C DC S/C DC-	Selects type of ADF signal input. If bearing indication is off by 180°, change selection to opposite polarity.
VALID	NONE LOW HIGH	Not shown if 429 or 429H is selected for ADF source.
ADF2	NONE 429 429H XYZ XYZ- S/C DC S/C DC-	Selects type of ADF signal input. If bearing indication is off by 180°, change selection to opposite polarity.
VALID	NONE LOW HIGH	Not shown if 429 or 429H is selected for ADF source
TCN Key	Blank by default	Enter the purchased 11 character key code to enable TACAN. Use the AUX and MEM keys to select the character and the MAP and TFC keys to move the cursor.



Configuration Field	Options	Comment
TCN1	NONE 429 429H 429-MC 429H-MC XYZ XYZ- 419	Selects type of TACAN signal input. If bearing indication is off by 180°, change selection to opposite polarity.
VALID	NONE HIGH LOW	Shown only when TACAN selection is XYZ or XYZ-.
DME	NONE DME 1 DME 2	Selects the source of DME data for the TACAN. Shown only when TACAN selection is XYZ or XYZ-.
TCN2	NONE 429 429H 429-MC 429H-MC XYZ XYZ- 419	Selects type of TACAN signal input. If bearing indication is off by 180°, change selection to opposite polarity.
VALID	NONE HIGH LOW	Shown only when TACAN selection is XYZ or XYZ-.
DME	NONE DME 1 DME 2	Selects the source of DME data for the TACAN. Shown only when TACAN selection is XYZ or XYZ-.
MARKERS	NONE ACTIVE L ACTIVE H 429 429H	Selects type of input from the marker beacon receiver.
THOLD	Default 003	Used to adjust the signal voltage threshold when ACTIVE L or ACTIVE H is selected for the marker beacon input.

## 7.1.5 Page 5: NAV/ILS/DME 1



The NAV/ILS/DME1 page allows the selection of the NAV1 and DME1 sources.

Configuration Field	Options	Comment
NAV	NONE 429 TO 429H TO 429 FR 429H FR COMP NO BRG	Selects NAV signal input. For 429 interfaces, the standard setting is 'TO'. Change to 'FR' if the received bearing information is 'from' the VOR station.
CAL	Default 17.0°	Only used when COMP is selected for the NAV signal input. A VOR test set should be used to accurately calibrate the displayed bearing pointer reading.
ENRGZ	NONE 429 429H ACTIVE H ACTIVE L ACTIVE H ALT ACTIVE L ALT	Selects ILS Energize input.  Alternate selection when using alternate Heading selection on compass page.
LOC DV	NONE 429 429H ANALOG COMP	Selects localizer signal input. The SN4500 has a built-in NAV converter to decode localizer validity and deviation from a composite signal input.  <b>If COMP is selected see following "Composite LOC Calibration procedure".</b>
GAIN		Used to calibrate LOC DV COMP

<b>Configuration Field</b>	<b>Options</b>	<b>Comment</b>
GS DV	NONE 429 429H ANALOG	Selects glideslope signal input.
OBS CAL	DEFAULT 0.0°	Calibrates NAV1 OBS.
DME	NONE 429 429-MC 568 KSD ANALOG	Selects DME signal input. For installations with one multichannel DME receiver used by NAV1 and NAV 2 select 429-MC.
HOLD	NONE ON HIGH ON LOW	Selects DME HOLD discrete input to active high or low. Not shown if DME type selection is NONE or 429-MC.
ZERO	DEFAULT 000	Present only if Analog DME is selected. Use to set zero point of DME input if necessary.
SCALE	DEFAULT 1.00	Present only if Analog DME is selected. Use to calibrate DME if necessary.

**OBS Calibration (Does not apply to 429)**

Note: While in the maintenance mode pressing and holding the CRS knob will toggle the display between the operational display and maintenance setup pages.

- a) In operational mode set the SN4500 course pointer (OBS) to zero degrees. Set the NAV test set to zero degrees.
- b) In Maintenance Mode, adjust the OBS CAL setting to center the deviation needle.
- c) Set the test set to 45 degrees. Turn the course pointer to re-center the deviation needle. If it is with a few degrees of 45 degrees, then proceed. Otherwise if it is about 90 degrees out, change the OBS ROT setting on Maintenance Page 10 to REVERSED and return to step a.
- d) Check the to/from flag on the SN4500 display. If to/from is reversed (and correct wiring has been verified) adjust the OBS CAL 180 degrees from the current setting.
- e) Check the course pointer at 30 degree increments and verify calibration.

**Composite LOC Calibration Procedure**

The following procedure applies to SN4500 installations that have been configured to use the SN4500 internal localizer converter.

LOC DV      COMP

This procedure does not apply for any other LOC DV setting such as Arinc 429 or Analog from an external LOC converter.

**Ramp or Bench Test:**

Perform the following procedure using the respective aircraft receiver. This test may be performed with a ramp test set or may be performed on the bench with a signal generator at nominal RF signal level (25uV or greater).

1. On the SN4500 NAV maintenance page, select LOC DV and change to COMP to select Composite Localizer.
2. Select GAIN.
3. Set 0 DDM (STD) on the test set, and tune the receiver to match the LOC frequency on the test set.
4. Adjust the SN4500 GAIN value so the average value of LOC AMPL reads 100.0 +/- 2.5.
5. Exit the SN4500 maintenance page to the normal pilot's LOC display.

6. On the test set remove both 90Hz and 150Hz simultaneously and verify the SN4500 display flags within 2 seconds.
7. On the test set select .155 DDM Left and verify that removing either tone individually will flag the SN4500 display within 5 seconds.
8. On the test set select .155 DDM Right and verify that removing either tone individually will flag the SN4500 display within 5 seconds.

Perform any other LOC performance tests desired.

7.1.6 Page 6: NAV/ILS/DME 2



The NAV/ILS/DME2 page allows the selection of the NAV2 and DME2 sources.

Configuration Field	Options	Comment
NAV	NONE 429 FR 429H FR 429 TO 429H TO COMP NO BRG	Selects NAV signal input. For 429 interfaces, the standard setting is 'TO'. Change to 'FR' if the received bearing information is 'from' the VOR station.
CAL	Default 17.0°	Only used when COMP is selected for the NAV signal input. A VOR test set should be used to accurately calibrate the displayed bearing pointer reading.
ENRGZ	NONE 429 429H ACTIVE H ACTIVE L ACTIVE H ALT ACTIVE L ALT	Selects ILS Energize input.  Alternate selection when using alternate Heading selection on compass page.

Configuration Field	Options	Comment
LOC DV	NONE 429 429H ANALOG COMP	Selects localizer signal input. The SN4500 has a built-in NAV converter to decode localizer validity and deviation from a composite signal input.  <b>If COMP is selected see “Composite LOC Calibration procedure” in the previous section.</b>
GAIN		Used to calibrate LOC DV COMP
GS DV	NONE 429 429H ANALOG	Selects glideslope signal input.
OBS CAL	DEFAULT 0.0°	Calibrates NAV2 OBS. See OBS calibration instructions for NAV1 in section 7.1.5.1.
DME	NONE 429 429-MC 568 KSD LO FR DME1 HI FR DME1	Selects DME signal input. For installations with a single DME receiver for NAV1 and NAV2, select LO FR DME1 (if low on DME2 Hold P1-40 indicates NAV2 selection) or HI FR DME1 (if high on DME2 Hold P1-40 indicates NAV2 selection). For installations with one multichannel DME receiver used by NAV1 and NAV 2 select 429-MC.
HOLD	NONE ON HIGH ON LOW	Selects DME HOLD discrete input to active high or low. Not shown if above DME selection is LO FR DME1 or HI FR DME1.

### OBS Calibration (Does not apply to 429)

Note: Maintenance mode and operational mode can be toggled by pressing and holding the CRS knob.

- f) In operational mode set the SN4500 course pointer (OBS) to zero degrees. Set the NAV test set to zero degrees.
- g) In Maintenance Mode, adjust the OBS CAL setting to center the deviation needle.
- h) Set the test set to 45 degrees. Turn the course pointer to re-center the deviation needle. If it is with a few degrees of 45 degrees, then proceed. Otherwise if it is about 90 degrees out, change the OBS ROT setting on Maintenance Page 10 to REVERSED and return to step a.

- i) Check the to/from flag on the SN4500 display. If to/from is reversed (and correct wiring has been verified) adjust the OBS CAL 180 degrees from the current setting.

Check the course pointer at 30 degree increments and verify calibration.



7.1.7 Page 7: GPS1



The GPS1 page allows the selection and configuration of the GPS1 input.

Configuration Field	Options	Comment
ANNUN	NONE ACTIVE L SERIAL	Automatically configured to a default setting when a GPS model is selected from the list below. This default setting should be reviewed to determine suitability for the specific installation.
LAT DV	NONE ANALOG SERIAL	Automatically configured to a default setting when a GPS model is selected from the list below. This default setting should be reviewed to determine suitability for the specific installation.
VERT DV	NONE ANALOG SERIAL	Automatically configured to a default setting when a GPS model is selected from the list below. This default setting should be reviewed to determine suitability for the specific installation.
VERT ENA	NONE ACTIVE H ACTIVE L VERT DV FLAG ACTV-H ALT ACTV-L ALT	Automatically configured to a default setting when a GPS model is selected from the list below. This default setting should be reviewed to determine suitability for the specific installation.

<b>Configuration Field</b>	<b>Options</b>	<b>Comment</b>
OBS CAL	DEFAULT 0.0°	Automatically configured when GPS is selected from list below. May require adjustment if the GPS receiver uses an RS-232 interface and has a resolver connected.
ARINC 429	429 429H	Used to select between ARINC 429 and ARINC 429 High Speed. This option is not available when a GPS receiver is selected that does not utilize an ARINC 429 interface.
APR ACTV	NONE ANNUN IN ACTIVE L ACTIVE H ACTV-H ALT ACTV-L ALT	GPS approach active source select.
GPS	Select from list	Select the appropriate model of GPS from the list. Press the SET soft key (CLR button) to program. NOTE: any time a GPS model is selected using the SET soft key, a review of the default settings in the above configuration fields should be made to confirm that they are appropriate for the installation.

7.1.8 Page 8: GPS2



The GPS2 page allows the selection and configuration of the GPS2 input.

Configuration Field	Options	Comment
ANNUN	NONE ACTIVE L SERIAL	Automatically configured to a default setting when a GPS model is selected from the list below. This default setting should be reviewed to determine suitability for the specific installation.
LAT DV	NONE ANALOG SERIAL	Automatically configured to a default setting when a GPS model is selected from the list below. This default setting should be reviewed to determine suitability for the specific installation.
VERT DV	NONE ANALOG SERIAL	Automatically configured to a default setting when a GPS model is selected from the list below. This default setting should be reviewed to determine suitability for the specific installation.
VERT ENA	NONE ACTIVE H ACTIVE L VERT DV FLAG ACTV-H ALT ACTV-L ALT	Automatically configured to a default setting when a GPS model is selected from the list below. This default setting should be reviewed to determine suitability for the specific installation.

<b>Configuration Field</b>	<b>Options</b>	<b>Comment</b>
OBS CAL	DEFAULT 0.0°	Automatically configured when GPS is selected from list below. May require adjustment if the GPS receiver uses an RS-232 interface and has a resolver connected.
ARINC 429	429 429H	Used to select between ARINC 429 and ARINC 429 High Speed. This option is not available when a GPS receiver is selected that does not utilize an ARINC 429 interface.
APR ACTV	NONE ACTIVE H ACTIVE L VERT DV FLAG ACTV-H ALT ACTV-L ALT	GPS approach active source select.
GPS	Select from list	Select the appropriate model of GPS from the list. Press the SET soft key (CLR button) to program. NOTE: any time a GPS model is selected using the SET soft key, a review of the default settings in the above configuration fields should be made to confirm that they are appropriate for the installation.

## 7.1.9 Page 9: FCS EMULATION



The FCS Emulation allows the selection and configuration of the FCS interface.

Configuration Field	Options	Comment
EXCITATN	EXT DC AC	Automatically configured when FCS is selected from list below.
HDG DAT	+RIGHT +LEFT	Automatically configured when FCS is selected from list below.
SCL V/D		Default settings reset when FCS is selected from list below.
MIN V		Default settings reset when FCS is selected from list below.
MAX V		Default settings reset when FCS is selected from list below.
REF V		Default settings reset when FCS is selected from list below.
CRS DAT	+RIGHT +LEFT	Automatically configured when FCS is selected from list below.
SCL V/D		Default settings reset when FCS is selected from list below.
MIN V		Default settings reset when FCS is selected from list below.
MAX V		Default settings reset when FCS is selected from list below.

Configuration Field	Options	Comment
REF V		Default settings reset when FCS is selected from list below.
FCS	Select from list	Select the appropriate emulation from the list. Press the SET soft key (CLR button) to program.

HDG V/D and CRS V/D increase or decrease the gain of the course or heading error relative to the lubber line, and normally match the volts/degree input of the associated autopilot computer. These values default when the FCS selection is initially set, but can be adjusted in-flight if necessary, in VFR conditions, as follows:

- a) Engage the autopilot in HDG mode. After the aircraft is established on the desired heading, move the heading bug knob a large amount and ensure that the aircraft turns to the heading bug and rolls out normally without instability, overshooting or undershooting to the desired heading. To correct for overshooting or instability, reduce the HDG V/D setting. To correct for undershooting, increase the HDG V/D setting.
- b) Engage the autopilot in NAV mode and turn off the NAV receiver to provide a zero course error. Repeat the tests and adjustments above using the course pointer and adjust the CRS V/D setting as appropriate.
- c) Use the REF V adjustment to center the heading and Course rollout if not precisely on the lubber line. This will rarely be required.

HDG DAT and CRS DAT allow the direction sensing to be reversed during installation. Changing these settings is identical to reversing H/C on a synchro control transformer.

The other settings on this page are not for installer adjustment except on advice of the factory, service bulletin, or service information letter.

Note that the adjustments are shown in the left column of values. The right column shows the default values for reference purposes.

7.1.10 Page 10: OBS / Relay / CDI



Configuration Field	Options	Comment
OBS ROT	NORMAL REVERSED DIFF A	Adjusts rotation of OBS. Select DIFF A when interfaced to 400HZ differential resolver.
RMT CRS	XYZ	
RMT HDG	XYZ	
BTSTRP	NONE NORMAL REVERSE	Enables bootstrap synchro heading output.
MODE	MASTER SLAVE	Selects NAV/GPS switching mode. In MASTER mode, the SN4500's NAV button is used to switch between NAV and GPS sources. In SLAVE mode a remote switch is used.
SENSE	NONE GPS1 GPS2 GPS1/GPS2 NAV2 GPS1/NAV2 GPS2/NAV2 G1/G2/N2	Enables relay sense input to verify relay switching. If a low is not detected on the relay sense input, the corresponding NAV source will be redlined on the pilot's display when selected.

Configuration Field	Options	Comment
NS GPS2	GPS2  NAV2 & GPS2	Normal operation of sense lines as described above in Sense selections. Use this selection and “NAV2” in Sense selections for installations with dual Garmin GNS Receivers where both receivers (All four NAV sources) are made available as NAV sources. This is the sense input (P3-5) for a relay which is wired to both the NAV-2 and GPS-2 relay outputs.
ILS LCK	DISABLE ENABLE	Enables/disables ILS Lockout feature of the ILS input for NAV1/NAV2.
AUTOSLEW	OFF NORMAL ON	Enables or disables the Pilot Menu selection of the AUTOSLEW feature. When set to OFF: AUTOSLEW is not available. When set to NORMAL: AUTOSLEW is pilot selectable in the Pilot Menu. When set to ON: 1) the AUTOSLEW feature is forced on. There is no selection available in the Pilot Menu. 2) During OBS operations course selection is from GPS navigator.
OBS	NORMAL REMOTE	When GPS is in OBS mode: NORMAL: CRS select from CRS knob or GPS. REMOTE: CRS select from GPS only (use for tandem training installations). The GPS/FMS must be configured to not accept external input for selected course.
LAT DEV	n/a	Monitors FCS voltage outputs.
OFFSET	n/a	Adjusts zero offset of the lateral deviation output*
VERT DV	n/a	Monitors FCS voltage outputs.
OFFSET	n/a	Adjusts zero offset of the vertical deviation output.*
FEEDBAK	n/a	Used to troubleshoot FCS FDBCK ERR messages. Contact product support for assistance.



Configuration Field	Options	Comment
ROLL STR  (Software version 2.02 and later)	Blank by default	Enter the purchased 11 character key code to enable roll steering. Use the BRG and MEM keys to select the character and the MAP and TFC keys to move the cursor.

\*This adjustment may be used to fine tune the autopilot localizer or glide slope tracking if the EHSI lat and vertical deviation outputs have been connected to the autopilot.

7.1.11 Page 11: WX-500



Configuration Field	Options	Comment
SOURCE	NONE 232	Set to 232 to enable WX-500 interface.
MODE IS	n/a	Displays current mode of the WX-500.
MODE RQ	WEATHER STRIKE TEST DEMO NOISE MONITOR SELF TEST	Selects mode of WX-500. Select WEATHER for normal operation.
ANT IS	n/a	Displays current antenna configuration.
ANT RQ	TOP BOTTOM UNKNOWN	Software selection of antenna location. Normally not used as the antenna location is set by jumpers on the WX-500.
INFO RQ	FAULT LIST CONFIGURATION ENVIRONMENT S/W VERSION	Requests information from WX-500. Information will be shown at the bottom of the display.

7.1.12 Page 12: Traffic & WXDL



Configuration Field	Options	Comment
WX LINK	NONE	Not currently supported.
WX KEY	Blank by default	Enter the purchased 11 character key code to enable data link weather. Use the BRG and MEM keys to select the character and the MAP and TFC keys to move the cursor.
TCAS KEY	Blank by default	Enter the purchased 11 character key code to enable traffic. Use the BRG and MEM keys to select the character and the MAP and TFC keys to move the cursor.

Configuration Field	Options	Comment
TCAS Model	Collins TCAS 4000 ARINC 429 TCAS LABELS* ARINC 429 ADSB LABELS* SERIAL GDL90(38.4)* SERIAL GDL90(115.2)* GARMIN OPT LEG ADS-B* Goodrich Skywatch HP Goodrich TCAS791/A Honeywell CAS-66 Honeywell CAS-67 Honeywell CAS-81 Ryan 9900BX TAS	Select the appropriate model of receiver from the list. Press the SET soft key (CLR button) to program. NOTE: Users of Honeywell KTA-810 systems should configure as CAS-66.  *ADS-B IN Traffic Selections. See installation drawings for proper selection.

7.1.13 Page 13: Video Setup



No selections available.

7.1.14 Page 14: STATUS



Sensor summary status.

7.1.15 Page 15: BRT/DATA BLK



Provides information regarding backlight color temperature. Configures the brightness controls for the buttons and the display.

Configuration Field	Options	Comment
BACKLIGHT	None	Monitors display color temperature.
Input Mode	Internal  28VDC 5VDC 5VAC	Select this option when no external dimming control is to be used. Select 28VDC, 5VDC, or 5VAC – as appropriate – when an external dimming control is to be used.
Max Brt		Adjusts voltage threshold for maximum display brightness. Option is not available when internal input mode is selected.
Min Brt Norm		Adjusts voltage threshold for minimum display brightness. Option is not available when internal input mode is selected.
Min Brt NVIS		Adjusts voltage threshold for minimum display brightness while in NVIS mode. Option is not available when internal input mode is selected.
Manual Brt Req		Measurement of current manual brightness setting. (1000 = full bright.)
Dim Bus In (P1-21)		Current voltage at pin P1-21.

LT Threshold		Sets the ambient light threshold at which the Auto Brightness control will display full brightness. Set Pilot Trim to 0 then set this number to the current Cockpit Brt reading when in the desired ambient light level that represents the transition to full brightness.
Scrn Brt Req	None	Represents the brightness leve (0-1 that is being commanded by the software.
Cockpit Brt	None	Indicates cockpit brightness level as read by light sensor
NVIS CONTROL	None	Monitors NVIS control signal.
Recorded Data	None	Contact Nighthawk Flight Systems, Inc. for information about downloading flight data for analysis.

### Calibrating the external brightness control:

#### NOTE:

- 1) Default values are displayed in the Max Brt, Min Brt Norm, and Min Brt NVIS fields - for each available bus voltage (5V DC, 5V AC, and 28V DC).
- 2) If changes are made to the default values of any of the Max Brt, Min Brt Norm, and Min Brt NVIS fields - and then any changes are made to the Input Mode field, the non-default values will be lost and will have to be reentered.
- 3) The maintenance page always displays at 100% brightness. You need to exit MAINT by pressing and holding the left knob to see the resulting brightness adjustment.
- 4) On units with MOD-A, the voltage shown on the DIM BUS IN (P1-21) field is half of the actual input voltage. Therefore the dimming range shown is from 0V to half of the maximum input voltage.

#### BEFORE performing calibration:

Select the “BRT/DATA BLK” maintenance page; select the correct EXTERNAL voltage bus value for Manual Brightness control.

**To calibrate maximum brightness:** Set aircraft to NVIS off and do the following from the BRT/DATA BLK maintenance page:

1. Select “Max Brt” with up/down arrow keys.
2. Set the aircraft external brightness bus to the maximum brightness setting.
3. Press the “SET” softkey to set the “Max Brt” setting to a value equal to the voltage shown in the “Dim Bus In” field.

**To calibrate minimum brightness:** Set aircraft to NVIS OFF and do the following from BRT/DATA BLK maintenance page:

1. Select “Min Brt Norm” with up/down arrow keys
2. Set the aircraft external brightness bus at the desired night-brightness voltage. This voltage will be displayed on-screen.
3. Press “SET” softkey. This will set  $V_{zero}$  (see graph below) at the current bus voltage minus 2.00 volts
4. Exit MAINT by pressing and holding the left knob and check the brightness balance with the rest of the cockpit. If you need further adjustment, re-enter BRT/DATA BLK maintenance page by pressing and holding the left knob and trim the “Min Brt V Norm” setting using “+/-” softkeys. A lower voltage setting number will INCREASE the brightness.
5. Repeat steps 1,2,3,4 with Min Brt NVIS selected

NOTE: From this point on the pilot will be able to trim the minimum brightness, if desired, using the ‘M’ button to enter the pilot’s menu.

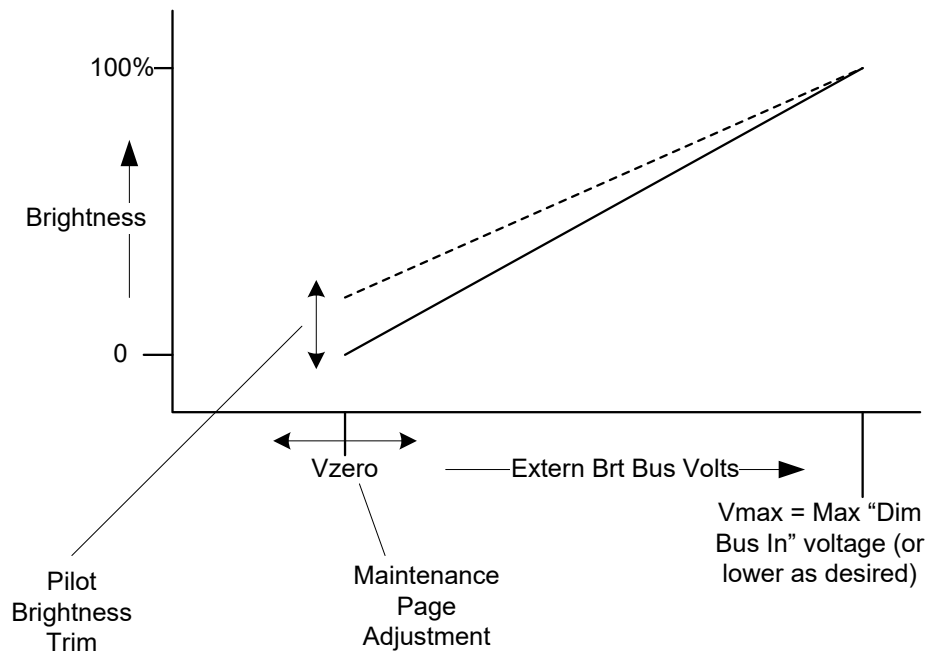



7.1.16 Page 16: Power



Monitors power input to the SN4500 including the #1 and #2 inverters.

## 7.1.17 Page 17: Software CRC

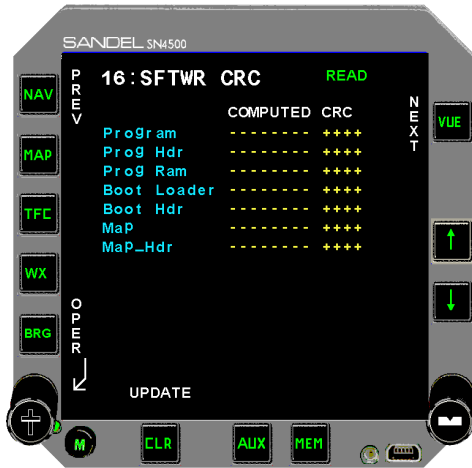

Displays CRC values for the software and database programs. Press the [UPDATE] soft key to re-calculate. Contact Nighthawk Flight Systems, Inc. if FAIL is annunciated for any of the values.

**8 Appendix B: Environmental Qualification**

**RTCA/D0-160E Environmental Qualification**

<b>NAMEPLATE NOMENCLATURE:</b> [(A2)(F1)Z]BAB[HR]XXXXXXXXZBABB[WW]M[XXE2F2X]XXAX	
<b>TYPE/MODEL NO:</b> SN4500	<b>TSO NUMBERS:</b> C113, -C3d, -C4e, -C6d, -C34e, -C35d, -C36e, -C40e, -C41d, -C118, -C119b, C195b
<b>MANUFACTURER'S SPECIFICATION AND/OR OTHER APPLICABLE SPECIFICATION:</b>	
a.) System Requirements For Model SN4500 Navigation Display, document number 82009-0010	
b.) Sandel SN4500 RTCA D0-160E Environmental Test Plan, document number 82009-0090	
c.) Sandel SN4500 EHSI Environmental Test Credit Analysis, document number 82009-0144	
<b>MANUFACTURER:</b> Nighthawk Flight Systems, Inc. – www.nighthawkfs.com	
<b>REVISION &amp; CHANGE NOS. OF D0-160:</b> Revision E	<b>DATE TESTED:</b> 11/12/05-12/14/05

ENVIRONMENTAL TESTS	RTCA/DO-160E SECTION	Equipment Test Category
Temperature & Altitude	4.0	
Low Temperature	4.5.1 & 4.5.2	[(A2)(F1)]
-Ground Survival		
-Operational		
High Temperature	4.5.3 & 4.5.4	
-Ground Survival		
-Operational		
In-Flight Loss of Cooling	4.5.5	
Altitude	4.6.1	Z
-Decompression	4.6.2	[(A2)(F1)]
-Overpressure	4.6.3	
Temperature Variation	5.0	B
Humidity	3.1	A
Operational Shock and Crash Safety	0	B
Vibration	8.0	[H R]
Explosion	9.0	X
Water-Proofness	10.0	X
Fluids Susceptibility	11.0	X
Sand and Dust	12.0	X
Fungus	13.0	X
Salt Spray	14.0	X
Magnetic Effect	15.0	Z
Power Input	16.0	B
Voltage Spike	17.0	A
Audio Frequency Susceptibility	18.0	B
Induced Signal Susceptibility	19.0	BC
Radio Frequency Susceptibility	20.0	[WW]
Radio Frequency Emission	21.0	M
Lightning Susceptibility	22.0	[XXE2F2X]
Lightning Direct Effects	23.0	X
Icing	24.0	X
Electrostatic Discharge	25.0	A
Fire, Flammability	26.0	X

## 9 Appendix C: Sample FAA Form 337

### NOTICE

*Weight and balance or operating limitation changes shall be entered in the appropriate aircraft record. An alteration must be compatible with all previous alterations to assure continued conformity with the applicable airworthiness requirements.*

#### 8. Description of Work Accomplished

*(If more space is required, attach additional sheets. Identify with aircraft nationality and registration mark and date work completed.)*

##### A. Installed the following equipment and components:

1. Nighthawk Flight Systems, Inc., SN4500 Navigation Display *(or as appropriate)*, Part Number SN4500-000 *(or as appropriate)*
2. Nighthawk Flight Systems, Inc., Clamp Fixture 4ATI, Part Number 61186.

##### B. The Nighthawk Flight Systems, Inc., SN4500 is interfaced to the following equipment:

1. Garmin International, GPS165, GPS Navigation Receiver (Approved for En route, Terminal, and Non-precision Approach). *(or as appropriate)*
2. AlliedSignal Electronics and Avionics, KX 165 Communications and Navigation Receiver. *(or as appropriate)*
3. AlliedSignal Electronics and Avionics, KX 155 Communications and Navigation Receiver. *(or as appropriate)*
4. AlliedSignal Electronics and Avionics, KR 22 Marker Receiver. *(or as appropriate)*
5. AlliedSignal Electronics and Avionics, KG 102A Directional Gyro. *(or as appropriate)*
6. AlliedSignal Electronics and Avionics, KMT 112 Magnetic Azimuth Transmitter. *(or as appropriate)*

*(By example state the following functional interface properties)...*

- C. The SN4500 receives and processes GPS navigation information for digital and waypoint display from the GPS165. These operations are considered supplemental navigation.
- D. The SN4500 receives and processes VOR, localizer, and glideslope deviation and composite audio for bearing display from the KX 165. These operations are considered primary means of navigation.

- E. The SN4500 receives and processes glideslope deviation and composite audio for bearing display from the KX 155.
- F. The SN4500 receives and processes marker beacon receiver information for illumination from the KR 22.
- G. The SN4500 receives and processes magnetic heading for digital and graphic display from the KG 102A and KMT 112.
- H. Interference and functional tests and inspections were accomplished with reference to Advisory Circular 23.1311. *(or as appropriate)*.
- I. A system design and analysis was conducted with reference to Advisory Circular 2X.1309-1(). *(or as appropriate)*.
- J. Federal Aviation Regulations, 2X.1301, 2X.1309(a), (b) and (d), 23.1311, 2X.1321(a), (b) and (d), 2X.1322, 2X.1327(a), 2X.1331, 2X.1351, 2X.1357(a)-(d), 23.1365, 2X.1381, 2X.1529, and 2X.1581 *(or as appropriate)*, were the basis of compliance.
- K. Installation approval is sought with reference to Flight Standards Information Bulletin, FSAW 95-09( ) (Amended), titled “Electronic Horizontal Situation Indicator (EHSI) Approvals”.
- L. The aircraft equipment list, and weight and balance were revised and recorded within the aircraft maintenance records.

All pertinent records of this alteration are on file at *(State your repair station name and number)*.

----- End -----

## 10 Appendix D: Sample Airplane Flight Manual Supplement

The following is being provided for installations in which the local FSDO requires an Airplane Flight Manual Supplement. This Sample is simply being provided for the convenience of the installer. Note that the cover page, table of contents and log of revisions has not been included here, and will be specific to your installation. The text is specific to the installed equipment, and also specifies ILS LOCKOUT operation. This text must be modified by the installation facility to be compatible with the installed equipment.

### SECTION I – GENERAL

The Nighthawk Flight Systems, Inc. SN4500 Primary Navigation Display is a compact four-inch instrument that performs the functions of a traditional Horizontal Situation Indicator combined with a two-pointer RMI. The SN4500 also displays a moving map, Stormscope® data, FIS-B data link weather, traffic information, marker beacon and GPS annunciators if the aircraft is appropriately equipped and configured.

***Add following text if Data Link Weather is installed:***

*FIS-B Weather Data is intended for the purpose of assisting in long-range strategic flight planning only. Please note that its delayed updating and lack of sufficient resolution makes it unsuitable for tactical maneuvering of the aircraft. It also differs significantly from on-board weather radar (which scans a narrow vertical angle) since it portrays radar returns from multiple ground stations extending from the surface up to the highest flight levels. For these reasons it may not even directly reflect the current flight conditions.*

### SECTION II LIMITATIONS

The system must utilize software version 1.01 or later FAA approved version.

The SN4500 Primary Navigation Display Pilots Guide, SPN 82009-PG (or applicable revision corresponding to the software version) must be immediately available to the flight crew.

The “CRC Self Test Failed” message must not appear on power-up if flight operations are predicated on the use of the SN4500.

***Add following text if Data Link Weather is installed:***

*The FIS-B weather display shall not be used for tactical maneuvering of the aircraft.*

### SECTION III EMERGENCY PROCEDURES

If the SN4500 fails to operate, use the magnetic compass as a heading source.

If the remote directional gyro (DG) becomes inoperative, the magnetic fluxgate will provide the heading, and the resulting heading display will respond much more slowly than normal. The compass rose changes color from white to amber, and digital heading numbers will be redlined.

If the fluxgate fails, the SN4500 will continue to display heading based on the directional gyro (DG) input. The compass rose changes color from white to amber, heading numbers will be redlined.

If the remote directional gyro (DG) fails and the fluxgate fails or the SN4500 is a slaved heading repeater, the compass rose will change from white to amber and continue to be displayed and the digital heading numbers will be redlined. Use the magnetic compass as a heading source.

If the “FCS FDBCK ERR” message appears when in autopilot coupled NAV or APPR mode, immediately monitor the lateral and vertical deviation indicators. If they are not tracking properly, immediately disable the autopilot and flight director NAV or APPR mode for the duration of the flight. HDG mode may still be used if the autopilot tracks the SN4500 HDG bug properly.

#### SECTION IV NORMAL PROCEDURES

The SN4500 NAV pushbutton selects the primary navigation source NAV1, NAV2 or GPS1. The selected source will drive the SN4500 deviation indicator and the autopilot.

ILS override will prevent selection of the GPS as long as an ILS frequency is tuned on NAV1 or NAV2. This will be annunciated on the SN4500 Navigation Display.

The SN4500 BRG pushbutton selects the bearing pointer 1 / 2 / both. The ‘M’ pushbutton followed by the BRG pushbutton selects the bearing pointer sources NAV1, NAV2, GPS1, GPS2, or ADF.

Annunciation of all GPS modes is accomplished by messages on the GPS receiver as well as on-screen annunciation on the SN4500.

*[If installed as a heading repeater (no direct fluxgate connection).]*

When manually slewing the remote compass system, the compass rose will change from white to amber and the digital heading numbers will be relined.

*[End heading repeater language.]*

#### **Add following text if Traffic is installed:**

*The traffic display mode is annunciated next to the TFC button. There are three different modes available which control how the traffic targets are displayed. Press the TFC button repeatedly to cycle through the different modes.*

*ON: Enables display of all targets within the selected map range (limited by the maximum range of the installed traffic system).*

*M: Manual mode. Traffic will be displayed at the selected map range only when alerting traffic is present, without auto ranging. Display range can be changed manually.*

*A: Auto mode. Traffic will be displayed at the selected map range only when alerting traffic is present, except that the map range will auto-scale to an appropriate range to show the traffic on-screen.*

*Manual (M) or Auto (A) modes do not display non-alerting traffic.*

**Add following text if Data Link Weather is installed:**

The SN4500 can display two types of weather information, precipitation and lightning. Lightning may be displayed from two independent sources, WX-500 Stormscope® or a FIS-B data link receiver. Both sources of lightning may be displayed simultaneously.

The SN4500 WX pushbutton selects the type weather to be displayed:

*PL: Precipitation & Lightning*

*P: Precipitation only*

*L: Lightning only*

The 'M' pushbutton followed by the WX pushbutton selects the lightning display data source, either WX500, WSI, or both. The number to the right of the WX annunciation displays the time in minutes since the last FIS-B precipitation data was received from the data link receiver.

Weather graphics depicted on the SN4500 data link weather display may differ significantly from the on-board weather radar or from out of the cockpit observations for one or more of the following reasons.

- Vertical strata information is not provided by the FIS-B weather service. The FIS-B weather data originates from NEXRAD ground based weather radar observations that include weather measurements up to 30,000 feet above the radar facility. The on-board weather radar is measuring returns relative to the current flight level.
- The FIS-B weather display is not exactly real time. Under certain circumstances the time from when the NEXRAD radar observations were made to when the data is displayed on the SN4500 can be as high as 40 minutes. During this time the position of the weather may have significantly changed or moved relative to the aircraft position.
- The graphic representation of precipitation is predicated on the level of reflected energy from moisture in the air mass (the more moisture in the air mass, the higher level of energy returned to the radar antenna). This may result in graphic presentation of precipitation on the SN4500 display when no visible moisture can be seen.

*Virga precipitation: the precipitation may be at a higher flight level and evaporating before reaching the current aircraft flight level.*

The circuit breaker for the SN4500 is located on the lower right circuit breaker panel labeled EHSI 1.

Refer to the SN4500 Pilot's Guide for other procedures, error messages, alerts and more detailed FIS-B data link weather information.

**Add following text if Reversionary Attitude is installed:**

**Pilot Integrity Check**



The attitude data source in Reversionary Mode is received from the same AHRS which supplies the HSI heading, typically a Sandel SG102. In order to assure that the reversionary attitude capability is working and available, this feature should be checked each flight prior to takeoff by activating the REV switch and comparing the display against the other aircraft attitude instruments.

During normal flight, if the HSI heading is intermittent erroneous or flagged, it may indicate that Reversionary Mode may be unavailable. Reversionary Mode may be tested at any time by activating the REV switch and comparing against the other aircraft attitude instruments.

Note: Due to the differences in operational characteristics between the AHRS and the other attitude gyros, the Reversionary Mode attitude may differ slightly from the other attitude instruments during or just after maneuvers. This difference should wash out after the aircraft returns to level flight with the slip-skid ball centered. This slight attitude difference during maneuvering should be considered normal.

## **SECTION V PERFORMANCE DATA**

No Change to AFM.

**11 Appendix E: Checkout Procedures**

**11.1 Functional Ground Test Procedures/Report**

The “Functional Ground Test Procedures/Report” below is for the purpose of simplifying ground tests of the SN4500. A copy of this report (and the “Operational Flight Check Procedures/ Report”) must be retained by the installing agency and a copy must be installed in the aircraft maintenance records. A copy must also be forwarded to Nighthawk Flight Systems, Inc. along with the Warranty Registration Form, Part Number 82009-0137, which should be mailed after operational acceptance.

Repair Station Name: _____
Number: _____
Address or Location: _____
City _____ ST _____ ZIP _____
A/C Make: _____ A/C Model: _____ A/C Serial No: _____
Work Order No.: _____ Technician: _____ Date Performed: _____

**COMPANY NAME**  
**COMPANY ADDRESS**  
**TELEPHONE/FAX**

**Ground Test Procedures/Report**  
**for**  
**Nighthawk Flight Systems, Inc. SN4500**

**Installed in**  
**{Aircraft make and model}**

**Registration No.** \_\_\_\_\_ **Serial No.** \_\_\_\_\_

**Document No.** \_\_\_\_\_ **Rev. - , Date**

11.1.1 Introduction

The following ground test procedures are to be performed after the SN4500 has been properly configured in the “Post-Installation Procedures”, but prior to performing flight test procedures. Successful completion of both the Ground Test and Flight Test procedures is necessary to support the claim that the SN4500, as installed, performs its intended function and is compatible with all aircraft systems. The ground test procedures contained herein will include testing of interfaces to other systems. Therefore, this ground test must be conducted in conjunction with, or subsequent to ground testing of other systems.

The following external system interfaces will be tested:

- Heading input from directional gyro
- Compass input from fluxgate sensor (if installed)
- Navigation data inputs: VOR/TCN/ILS/GS, ADF, DME, GPS and FMS (if installed)
- Annunciator inputs from a marker beacon receiver (if installed)
- Annunciator inputs from a GPS receiver (if installed)
- Lightning-strike inputs from a WX-500 Stormscope® sensor (if installed)
- Remote NAV source switching relays and/or indicators (if installed)
- External NVIS control switch (if installed)

11.1.2 Test Procedures and Results

11.1.2.1 Physical Installation

Verify that the SN4500 clamp has been properly installed in accordance with the manufacturer’s instructions, that any external switches affecting SN4500 operation have been clearly labeled, and that a trip-free re-settable circuit breaker labeled “EHSP” is clearly visible. Ensure that cooling air intake is not obstructed.

**Completed** \_\_\_\_\_ **Comment** \_\_\_\_\_

11.1.2.2 Wiring Verification and Initial Power-Up

Perform a 100% continuity check of all aircraft wiring to verify in accordance with installation wiring diagrams.

**Completed** \_\_\_\_\_ **Comment** \_\_\_\_\_

Power check all wiring to ensure that 28 Vdc and 26 Vac (if applicable) are applied to the proper pins and nowhere else.

**Completed** \_\_\_\_\_ **Comment** \_\_\_\_\_

Install the SN4500 into the clamp tray and verify full connector mating and that the unit installs without obstruction.

**Completed** \_\_\_\_\_ **Comment** \_\_\_\_\_

Activate the aircraft master switch and avionics master switch, if installed. Verify that the SN4500 display illuminates within 30 seconds.

Switch on all equipment interfaced to the SN4500 such as NAV receivers, gyros, and marker beacon receivers.

**Completed** \_\_\_\_\_ **Comment** \_\_\_\_\_

11.1.2.3 System Configuration

If not previously accomplished, perform the “Post-Installation Procedures” included in the Appendix of the SN4500 Installation Guide. These procedures describe how to configure the SN4500 for compatibility with installed systems.

**Completed** \_\_\_\_\_ **Comment** \_\_\_\_\_

11.1.2.4 System Functions

11.1.2.5 Compass System Interface

Power up the system and verify that within 3 minutes the compass card is displayed in white and agrees with the heading on a magnetic compass.

**Completed** \_\_\_\_\_ **Comment** \_\_\_\_\_

Disable the fluxgate excitation to the SN4500. Verify that within 10 seconds the compass digital heading is flagged. Restore the fluxgate excitation and verify that within 10 seconds the display is fully restored. Note: If fluxgate excitation and gyro are interconnected, remove both signals simultaneously and look for simultaneous failure indications.)

Completed \_\_\_\_\_ Comment \_\_\_\_\_

Remove power to (or otherwise disable) the remote directional gyro. Verify that the compass card is displayed in amber and that a warning message is displayed on the SN4500 which requires operator acknowledgement.

Completed \_\_\_\_\_ Comment \_\_\_\_\_

If the SN4500 is installed as a heading repeater (no direct fluxgate connection) and interfaced with a Directional Gyro (DG) that “Flags Invalid” when operated in “Free Gyro Mode”. Verify that the SN4500 continues to display the compass rose while the gyro compass is manually slewed left and right. This test must be performed after the SN4500 has been powered for a minimum of 4 minutes.

Completed \_\_\_\_\_ Comment \_\_\_\_\_

#### 11.1.2.6 NAV Source Selection

**If the SN4500 is configured in “master” mode (no external NAV/GPS switch):**

Press the [NAV] button repeatedly and verify that the screen legend next to the button cycles correctly through the configured NAV sources, i.e. NAV1, NAV2, GPS1, GPS 2, TACAN 1, TACAN 2 (or as configured). For each NAV source, create valid and invalid NAV conditions and verify correct display of the SN4500 NAV flag for each receiver (the large red “X” through the CDI). For each VOR/LOC source, verify that tuning an ILS frequency causes the glideslope (vertical deviation) scale to display on the screen, even if it is flagged.

Completed \_\_\_\_\_ Comment \_\_\_\_\_

[If ILS Lockout is enabled] Press the [NAV] button and select a source *other than* NAV1, such as GPS or NAV2 (if configured). Tune NAV1 to an ILS frequency, and verify that after a one-second delay, the selected NAV source automatically reverts to NAV1. Verify that as long as NAV1 is tuned to an ILS frequency, pressing the [NAV] button will not change the NAV source, but instead will display the message “NAV1 TUNED TO LOC”. Verify that upon *de-tuning* the ILS frequency from NAV1, the NAV source selection returns to its original state.

Completed \_\_\_\_\_ Comment \_\_\_\_\_

If NAV2 is configured, tune both NAV1 and NAV2 to an ILS frequency and verify that

NAV1 remains selected. Detune the ILS frequency on NAV1 and verify that the display reverts to NAV2.

**Completed** \_\_\_\_\_ **Comment** \_\_\_\_\_

**If the SN4500 is configured in “slave” mode (using external NAV/GPS switch):**

Verify that pressing NAV does not change the selected NAV source, but instead displays an advisory message.

**Completed** \_\_\_\_\_ **Comment** \_\_\_\_\_

Verify that the external NAV/GPS switch arrangement correctly controls the selected NAV source on the SN4500, including any ILS lockout scheme, if implemented.

**Completed** \_\_\_\_\_ **Comment** \_\_\_\_\_

11.1.2.7 LOC/GS Deviation

Using a ILS test signal generator verify proper deviation of the LOC/GS deviation indicators on the SN4500. Tune the NAV1 to match the ILS test signal generator frequency (usually 108.1 MHz.). Select LOC 1 on the SN4500. Adjust the signal generator to verify the following indications on the SN4500 LOC deviation indicator, center, 2 dots fly left, 2 dots fly right, and LOC flagged. Adjust the signal generator to verify the following indications on the SN4500 GS deviation indicator, center, 2 dots fly up, 2 dots fly down, and GS flagged. Repeat for NAV2.

**Completed** \_\_\_\_\_ **Comment** \_\_\_\_\_

11.1.2.8 BRG Source Selection

Press M and then press BRG on the SN4500 and verify that all installed NAV sources are presented for *each* bearing pointer (NAV1, NAV2, TCN 1, TCN2, ADF1, ADF2, GPS1, GPS2 as installed). In addition, bearing pointer 1 will have “AUTO” listed as a choice.

**Completed** \_\_\_\_\_ **Comment** \_\_\_\_\_

Select each available NAV source for each pointer, and verify in turn that the depicted bearing corresponds to the actual bearing shown on the NAV source.

**Completed** \_\_\_\_\_ **Comment** \_\_\_\_\_

## 11.1.2.9 DME Selection

If two DME receivers are installed and configured:

Verify that pushing NAV to select between NAV1 and NAV2 also switches the appropriate DME readout on the SN4500 distance display. Press M and then BRG to configure bearing pointer 1 to be NAV1 and bearing pointer 2 to be NAV2. Press BRG to display both pointers simultaneously. Verify that the correct DME data is displayed in each bearing pointer data block.

**Completed** \_\_\_\_\_ **Comment** \_\_\_\_\_

If a single DME receiver is installed and is not switchable between NAV1 and NAV2:

Verify that pushing NAV to select between NAV1 and NAV2 causes the DME readout to be displayed when NAV1 is selected, and the DME readout to be removed when NAV2 is selected. Press M and then press BRG to configure bearing pointer 1 to be NAV1 and bearing pointer 2 to be NAV2. Press BRG to display both pointers simultaneously. Verify that DME data is displayed in the bearing pointer 1 data block, and that no distance data is displayed in the bearing pointer 2 data block.

**Completed** \_\_\_\_\_ **Comment** \_\_\_\_\_

If a single DME receiver is installed and is switchable between NAV1 and NAV2:

Verify that pushing NAV to select between NAV1 and NAV2 causes either the correct DME readout to be displayed or a “none” indication, depending on the position of the external DME select switch (if installed). Press M and then press BRG to configure bearing pointer 1 to be NAV1 and bearing pointer 2 to be NAV2. Press BRG to display both pointers simultaneously. Verify that DME data is displayed in the bearing pointer 1 data block when DME is externally switched to NAV1. Verify that when DME is externally switched to NAV2, an arrow (“→”) appears in the DME portion of the pointer 1 data block, and that DME distance data is displayed in the bearing pointer 2 data block. Press BRG to deselect pointer 1 and only display pointer 2. Verify that proper DME data is now displayed in the bearing pointer 2 data block.

**Completed** \_\_\_\_\_ **Comment** \_\_\_\_\_

If an external DME HOLD control is configured:

Verify that enabling DME HOLD displays the “H” symbol for each installed DME receiver so equipped.

**Completed** \_\_\_\_\_ **Comment** \_\_\_\_\_



## 11.1.2.10 GPS Interface and Control

For each GPS receiver installed and configured:

Allow the receiver to acquire a valid position fix, and press NAV on the SN4500 to select that receiver as a NAV source. Enter either a single destination waypoint or a flight plan on the GPS receiver and select normal (LEG) navigation mode. Verify that the course pointer automatically rotates to the desired track, and that groundspeed and waypoint ID are displayed on the SN4500.

**Completed** \_\_\_\_\_ **Comment** \_\_\_\_\_

Press M and then press BRG and assign either bearing pointer to the selected GPS receiver. Verify that the bearing pointer corresponds to the bearing-to-waypoint, and that the distance displayed matches the display on the actual receiver.

**Completed** \_\_\_\_\_ **Comment** \_\_\_\_\_

If the GPS is equipped with an OBS mode (Bendix/King) or a HOLD mode which enables course resolver input (Garmin), select the OBS or HOLD mode and verify that rotating the course select knob turns the course pointer. Verify that the needle centers on the correct bearing to waypoint.

**Completed** \_\_\_\_\_ **Comment** \_\_\_\_\_

Enter the “CDI and Annunciator Test” mode of the GPS if available. Verify proper response of the GPS annunciators, if configured to display on the SN4500. If external mode selection is enabled on the SN4500, verify that the GPS pushbutton softkeys accessed in NAV menu control the proper GPS functions.

**Completed** \_\_\_\_\_ **Comment** \_\_\_\_\_

## 11.1.2.11 Marker Beacon Interface

If a marker beacon receiver is interfaced to the SN4500:

With a marker beacon test set, generate outer, middle, and inner marker signals respectively. Verify that the appropriate annunciation appears on the SN4500.

**Completed** \_\_\_\_\_ **Comment** \_\_\_\_\_

Press “TEST” mode on the marker beacon receiver, and verify that the “MT” symbol

appears on the SN4500.

**Completed** \_\_\_\_\_ **Comment** \_\_\_\_\_

#### 11.1.2.12 Flight Control System Interface

If the SN4500 is interfaced to a flight control system (FCS):

Place the FCS mode selector in heading (HDG) mode. Verify that the aircraft controls respond correctly as the heading knob is turned and the heading bug moves around the SN4500 display.

**Completed** \_\_\_\_\_ **Comment** \_\_\_\_\_

Place the FCS mode selector in nav-coupled (NAV) mode. Verify that the aircraft controls respond correctly as the course select knob is turned and the course pointer moves around the SN4500 display.

**Completed** \_\_\_\_\_ **Comment** \_\_\_\_\_

Switch sequentially through all the NAV sources and verify that the autopilot L/R and U/D (if applicable) signals responds correctly to the selected receiver.

**Completed** \_\_\_\_\_ **Comment** \_\_\_\_\_

#### 11.1.2.13 Stormscope ® Interface

If the SN4500 is interfaced to a WX-500 remote lightning sensor:

Enable the Stormscope® display by within the WX menu. Verify that “WX” is annunciated on the SN4500 display.

**Completed** \_\_\_\_\_ **Comment** \_\_\_\_\_

Press M and then WX and select “WX TEST”. Verify that the word “TEST” is annunciated on the SN4500 display for approximately 10 seconds, and is then replaced by “WX”.

**Completed** \_\_\_\_\_ **Comment** \_\_\_\_\_

#### 11.1.2.14 Traffic

If the SN4500 is interfaced to a TAS/TCAS processor or ADS-B IN receiver:

Activate the TEST function on the traffic system and verify that the test pattern is displayed on the SN4500.

**Completed** \_\_\_\_\_ **Comment** \_\_\_\_\_

11.1.2.15 NVIS Control

If the SN4500 supports NVIS compatibility, (SN4500-XXXN).

Activate the external NVIS control switch and verify “NVIS” is annunciated on the lower right of the screen.

**Completed** \_\_\_\_\_ **Comment** \_\_\_\_\_

11.1.2.16 Reversionary Display Control

If the SN4500 is configured to support the Reversionary Attitude Display.

Activate the external ‘REV’ control switch and verify the SN4500 displays a representative horizon and compass arc for the attitude of the aircraft. Place the ‘REV’ control switch back in the normal position and verify the SN4500 switches back to the normal HSI display.

**Completed** \_\_\_\_\_ **Comment** \_\_\_\_\_

11.1.2.17 Additional Testing

Perform any additional tests deemed necessary.

**Completed** \_\_\_\_\_ **Comment** \_\_\_\_\_

11.1.3 EMI/RFI Test Procedures

11.1.3.1 Nav/Com Testing

Apply power to the avionics bus and ensure that all electrical equipment, including the SN4500, is operating normally. Open the squelch on the primary communications radio and tune the radio to each whole megahertz frequency sequentially. Attempt to discern any interference caused by the SN4500. Pull the SN4500 breaker if interference is noted, to verify that the SN4500 is the source.

**Completed** \_\_\_\_\_ **Comment** \_\_\_\_\_

Repeat for the secondary communications radio.

**Completed** \_\_\_\_\_ **Comment** \_\_\_\_\_

Tune the primary navigation radio to 112 MHz and enable the audio output. Attempt to discern any audible interference cause by the SN4500.

**Completed** \_\_\_\_\_ **Comment** \_\_\_\_\_

Repeat for the secondary navigation radio.

**Completed** \_\_\_\_\_ **Comment** \_\_\_\_\_

Transmit on the frequencies 118.000 MHz, 126.975 MHz, and 135.975 MHz on the primary communications radio and attempt to discern any changes in the SN4500 display.

**Completed** \_\_\_\_\_ **Comment** \_\_\_\_\_

Repeat for the secondary communications radio.

**Completed** \_\_\_\_\_ **Comment** \_\_\_\_\_

11.1.3.2 General Testing

Observe any unusual interaction between the transponder, DME, ADF or Marker Beacon receivers, and the SN4500 when switching power to any equipment.

**Completed** \_\_\_\_\_ **Comment** \_\_\_\_\_

11.1.3.3 Additional Testing

Perform any additional EMI/RFI-related tests deemed necessary.

**Completed** \_\_\_\_\_ **Comment** \_\_\_\_\_

## 11.2 Operational Flight Test Procedures/Report

The following “Operational Flight Check Procedures/Report” is for the purpose of simplifying the in-flight operational check of the SN4500. A copy of this report (and the “Functional Ground Test Procedures/ Report”) must be retained by the installing agency and a copy must be installed in the aircraft maintenance records. A copy must also be forwarded to Nighthawk Flight Systems, Inc. along with the Warranty Registration Form, Part Number 82009-0137, which should be mailed after operational acceptance.

**COMPANY NAME**  
**COMPANY ADDRESS**  
**TELEPHONE/FAX**

**Flight Test Procedures/Report**  
**for**  
**Nighthawk Flight Systems, Inc. SN4500**

**Installed in**  
**{Aircraft make and model}**

**Registration No.** \_\_\_\_\_ **Serial No.** \_\_\_\_\_

**Document No.** \_\_\_\_\_ **Rev. - , Date**

11.2.1 Introduction

The Flight Test Procedures described below are to be performed after both the Post-Install Procedures and the Ground Test Procedures are performed. Successful completion of the Flight Test Procedures will then satisfy the criteria for operational acceptance of the SN4500 installation.

Specific procedures are not provided for many of the tests herein, due to differences in installed options and aircraft configurations. Refer to the SN4500 Pilot’s Guide and the proposed Airplane Flight Manual Supplement for operational details of the equipment.

Each test item is followed by a space for the initials of the person performing the procedure, and a space for a description of any observations or anomalies. Determination of a successful flight test is made after analysis of these observations.

11.2.2 Test Procedures

11.2.2.1 Pre-Departure Operations

Apply power to the SN4500 and all associated equipment. Determine that all equipment initializes and functions normally.

Verify that the SN4500 internal brightness control can control the brightness of the SN4500 and that a satisfactory brightness level can be attained.

**Completed** \_\_\_\_\_ **Comment** \_\_\_\_\_

Evaluate the display of the SN4500 for readability.

**Completed** \_\_\_\_\_ **Comment** \_\_\_\_\_

Evaluate the intensity properties of the SN4500 display under both direct and indirect sunlight conditions, and in nighttime operation conditions.

**Completed** \_\_\_\_\_ **Comment** \_\_\_\_\_

Check the function of all buttons and knobs, and confirm that all controls are operational.

**Completed** \_\_\_\_\_ **Comment** \_\_\_\_\_



## 11.2.2.2 Enroute Operations

Cycle various aircraft electrical equipment items such as lights, landing gear, radar, windscreen heat, and anti-icing boots. Verify that none causes interference on the SN4500 display.

**Completed** \_\_\_\_\_ **Comment** \_\_\_\_\_

Verify proper operation of one or both VHF NAV receivers (as installed), both as NAV sources and as bearing pointer sources. Simultaneously verify proper channeling and display of one or both DME sources, as installed.

**Completed** \_\_\_\_\_ **Comment** \_\_\_\_\_

Verify proper operation of one or both TACAN receivers (if installed), both as NAV sources and as bearing pointer sources.

**Completed** \_\_\_\_\_ **Comment** \_\_\_\_\_

Verify proper operation of one or both long-range NAV receivers (as installed), both as NAV sources and as bearing pointer sources. Include verification of map display of waypoints.

**Completed** \_\_\_\_\_ **Comment** \_\_\_\_\_

Verify proper operation of one or both ADF sources as bearing pointers if installed.

**Completed** \_\_\_\_\_ **Comment** \_\_\_\_\_

For each NAV source, verify proper operation of the flight control system, both in NAV (coupled) mode and in heading mode.

**Completed** \_\_\_\_\_ **Comment** \_\_\_\_\_

Verify proper operation of the WX-500 Stormscope® sensor, if installed.

**Completed** \_\_\_\_\_ **Comment** \_\_\_\_\_

## 11.2.2.3 GPS Approach Operations

If installed, configure each approach-capable GPS receiver for a non-precision approach. Conduct the approach and evaluate proper operation of:

- CDI sensitivity and deflection
- Resolver interface in OBS or HOLD mode
- GPS annunciator display on the SN4500 (as installed)
- External GPS mode control switches on the SN4500 (as installed)
- Waypoint display when map is enabled on the SN4500

**Completed** \_\_\_\_\_ **Comment** \_\_\_\_\_

## 11.2.2.4 ILS Approach Operations

Conduct at least one fully coupled ILS approach (in VFR conditions) for each VHF NAV receiver installed. During the approach, verify proper operation of:

- Lateral deviation display (CDI) in both ARC and 360 modes
- Vertical deviation display in both ARC and 360 modes
- Marker beacon annunciation on the SN4500, if installed
- Flight control system operation.

**Completed** \_\_\_\_\_ **Comment** \_\_\_\_\_

## 11.2.2.5 TACAN Approach Operations

If installed, conduct at least one TACAN approach (in VFR conditions). Conduct the approach and evaluate proper operation of:

- CDI sensitivity and deflection

**Completed** \_\_\_\_\_ **Comment** \_\_\_\_\_

11.2.2.6 Additional Testing

Perform any additional flight testing deemed necessary.

**Completed** \_\_\_\_\_ **Comment** \_\_\_\_\_

**12 Appendix F: STC's**

Reference Nighthawk Flight Systems, Inc. Website <https://www.nighthawkfs.com/sn4500-support/sn4500-other-documents>

**13 Appendix G: List of Effective Drawings and Attachments**

<b>Drawing</b>	<b>Rev</b>	<b>Title</b>
82009-07	A	LAYOUT, SN4500
82009-05	A	Layout, SN4500 INSTALLATION
82009-10 pp 1	B	POWER AND INVERTER
82009-10 pp 2	B	FCS DEVIATION (INT RELAY)
82009-10 pp 3	C	FCS DEVIATION (EXT RELAY)
82009-10 pp 4	B	FCS GENERIC CRS/HDG DATUM
82009-10 pp 5	B	BENDIX AUTOPILOTS
82009-10 pp 6	B	BENDIX /KING AUTOPILOTS
82009-10 pp 7	A	CENTURY IV AUTOPILOTS
82009-10 pp 8	A	CENTURY 1C388 COUPLERS
82009-10 pp 9	A	S-TEC AUTOPILOTS
82009-10 pp 10	B	KING KG102A – SN4500 SLAVING
82009-10 pp 11	A	KCS55 – BOOTSTRAP XYZ
82009-10 pp 12	B	S-TEC (AERONETICS) GYRO
82009-10 pp 13	A	XYZ GYRO (GYRO SELF SLAVED)
82009-10 pp 14	B	XYZ GYRO
82009-10 pp 15	B	XYZ GYRO WITH KMT112
82009-10 pp 16	B	COLLINS PN101 UPGRADE
82009-10 pp 17	A	MID-CONTINENT 4305
82009-10 pp 18	B	SN4500 COMPASS BOOTSTRAP
82009-10 pp 19	C	KCS-55 REMOVAL (REF)
82009-10 pp 20	B	NAV-1RS-232 GPS (EXT RELAY)
82009-10 pp 21	C	NAV-1 RS-232 GPS (INT RELAY)
82009-10 pp 22	C	NAV-1 / ARINC-429 GPS (EXT RELAY)
82009-10 pp 23	C	NAV-1 / ARINC-429 GPS (INT RELAY)
82009-10 pp 24	E	NAV-2, GPS-2 (RS232), SUPERFLAGS
82009-10 pp 25	A	KLN-94 INTERFACE WITH ANALOG NAV
82009-10 pp 26	B	SINGLE SN4500 GNS480
82009-10 pp 27	D	SINGLE SN4500 SINGLE GNS430/530 GTN6XX/7XX
82009-10 pp 28	G	SINGLE SN4500 DUAL GNS430/530/GTN6XX/7XX
82009-10 pp 29	A	GPS SWITCH / ANNUNCIATORS
82009-10 pp 30	B	RESOLVER INTERCONNECT
82009-10 pp 31	B	ADF

## Appendix G: List of Effective Drawings and Attachments

<b>Drawing</b>	<b>Rev</b>	<b>Title</b>
82009-10 pp 32	A	MARKER BEACON
82009-10 pp 33	C	DME, KING SERIAL AND ANALOG
82009-10 pp 34	B	DME: ARINC 568
82009-10 pp 35	C	TCAS/TRAFFIC
82009-10 pp 36	A	TCAS II
82009-10 pp 37	B	WX-500
82009-10 pp 38	D	WSI DATA LINK RECEIVER
82009-10 pp 39	A	COCKPIT REMOTE INTERFACES
82009-10 pp 40	B	SN4500 with SG102 ARINC 429 or 407 Interface
82009-10 pp 41	A	SN4500 with TACAN
82009-10 pp 42	A	NVIS CONTROL
82009-10 pp 43	B	REVERSIONARY ATTITUDE DISPLAY OPTION
82009-10 pp 44	A	ADS-B In Traffic

REV. ZONE		DESCRIPTION	A/R	DATE	APPROVED
A		INITIAL RELEASE		11/03/06	G. BLOCK
A1		CHANGED COMPANY NAME TO NIGHTHAWK FLIGHT SYSTEMS, INC.	5081	05/12/22	J.H.

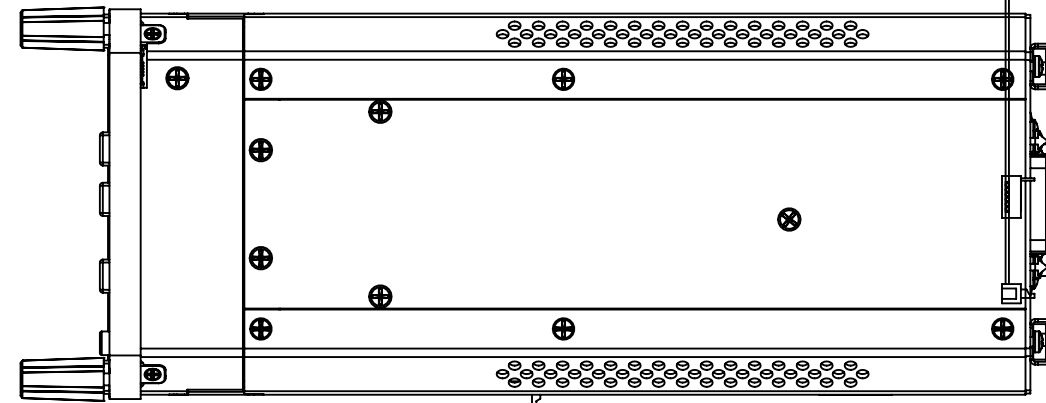
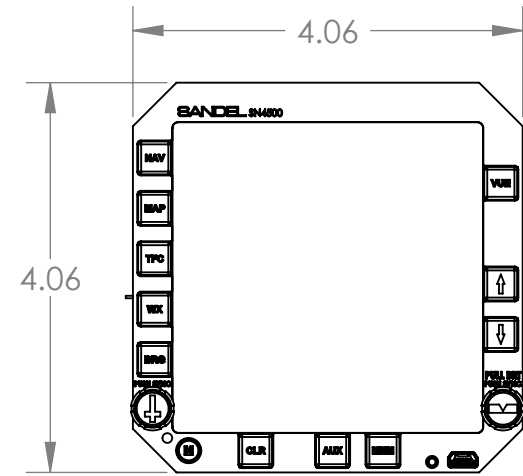
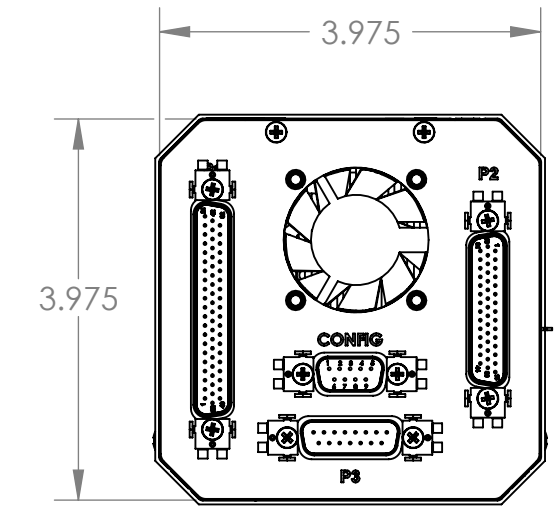
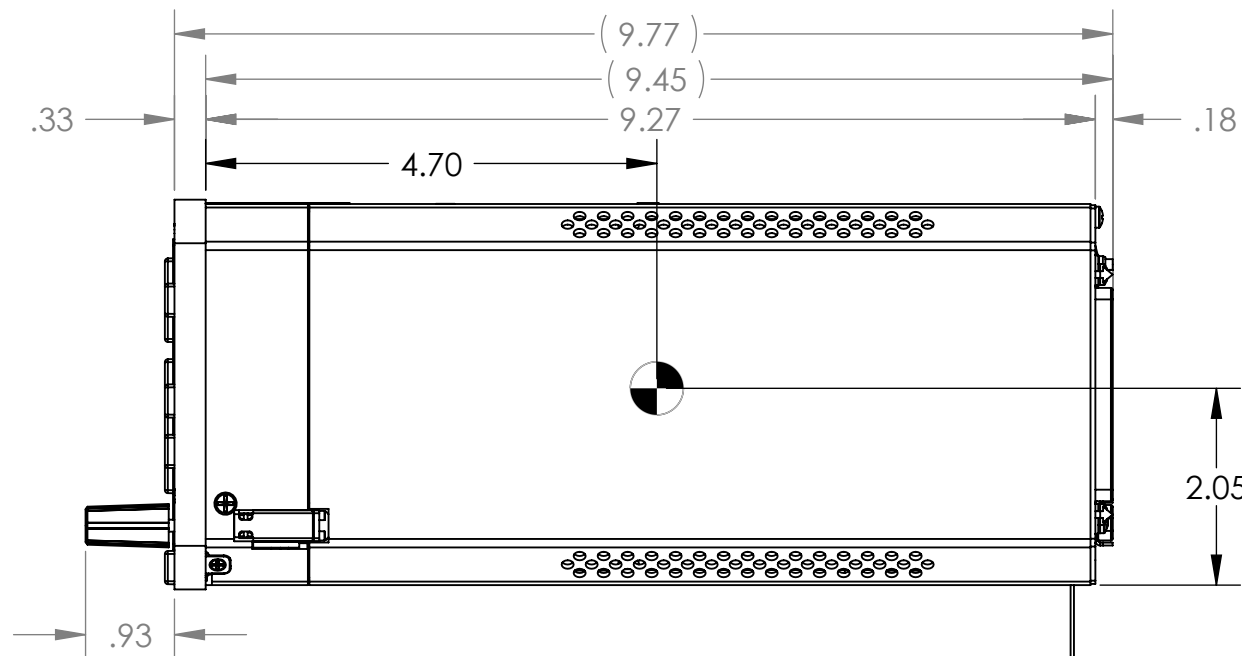
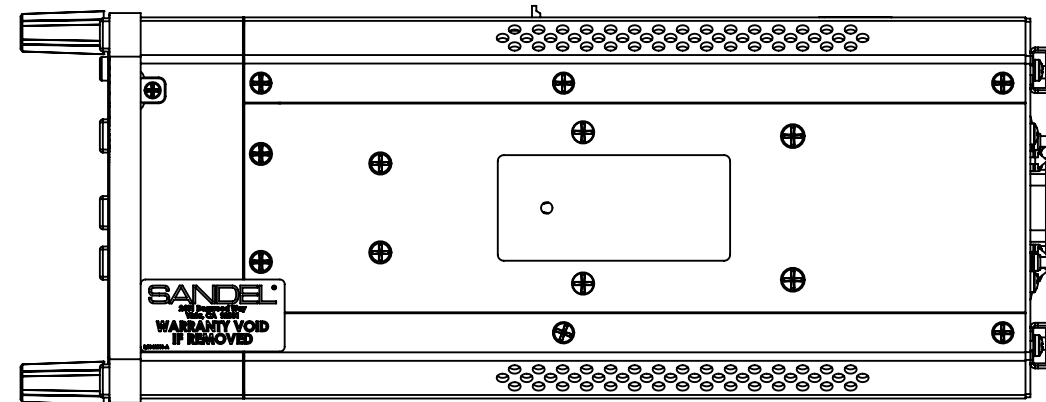

UNLESS OTHERWISE SPECIFIED DIMENSIONS ARE IN INCHES TOLERANCES ARE:  
 DECIMALS .XX ± .01  
 .XXX ± .005  
 ANGLES ± .5°

CAD GENERATED DRAWING, DO NOT MANUALLY UPDATE	
APPROVALS	DATE
DRAWN T. MORRISON	11/01/06
CHECKED M. WILEY	11/01/06
RESP ENG T. MORRISON	11/01/06
MFG ENG	
APPROVAL	

**NIGHTHAWK FLIGHT SYSTEMS, INC.** VISTA, CA

# LAYOUT, SN4500

SIZE	CAGE CODE	DWG. NO.	CATEGORY	REV.
B	3T1Z4	82009	07	A1

SCALE 1:2 CAD FILE & NOTED 82009-07 LAYOUT, SN4500 SHEET 1 OF 1

CONFIDENTIAL: PROPRIETARY RIGHTS NOTICE: ALL RIGHTS RESERVED. THIS MATERIAL CONTAINS THE VALUABLE PROPERTIES AND TRADE SECRETS OF NIGHTHAWK FLIGHT SYSTEMS, INC. OF CALIFORNIA, UNITED STATES OF AMERICA, EMBODYING SUBSTANTIAL CREATIVE EFFORTS AND CONFIDENTIAL INFORMATION, IDEAS, AND EXPRESSIONS, NO PART OF WHICH MAY BE REPRODUCED OR TRANSMITTED IN ANY FORM OR BY ANY MEANS, ELECTRONIC, MECHANICAL OR OTHERWISE, INCLUDING PHOTOCOPYING AND RECORDING, OR IN CONNECTION WITH ANY INFORMATION STORAGE OR RETRIEVAL SYSTEM WITHOUT THE PERMISSION IN WRITING FROM NIGHTHAWK FLIGHT SYSTEMS, INC. COPYRIGHT AN UNPUBLISHED WORK. NIGHTHAWK FLIGHT SYSTEMS, INC.

8 7 6 5 4 3 2 1

D C B A

D C B A

8 7 6 5 4 3 2 1

NOTES:

1. LOCATE PANEL CUT OUT/4 ATI CLAMP WITH SUFFICIENT CLEARANCE ALL AROUND (REF. ARINC SPECIFICATION 408A)
2. ATTACH CLAMP TO INSTRUMENT PANEL USING 2 EA .138-32 X .75 PAN HEAD MACHINE SCREW, CROSS RECESSED (MS35214-29, OR EQ.). TORQUE SCREWS TO 6 TO 10 IN-LBS.
3. INSTALL 2 EA ADJUSTING SCREWS, .164-32 X 2.00 PAN HEAD MACHINE SCREW, CROSS RECESSED. TORQUE SCREWS TO 6 TO 10 IN-LBS.
4. COMPLETE INSTALLATION PER INSTALLATION MANUAL, SANDEL PART NUMBER 82009-IM (CURRENT REVISION)

REVISIONS					
REV.	ZONE	DESCRIPTION	A/R	DATE	APPROVED
B		A/R 814 INITIAL RELEASE		11/03/06	G. BLOCK
B1		ADD TORQUE CALLOUT TO NOTE 2 AND NOTE 3 CHANGED COMPANY NAME TO NIGHTHAWK FLIGHT SYSTEMS, INC.	5047	05/09/22	J.H.

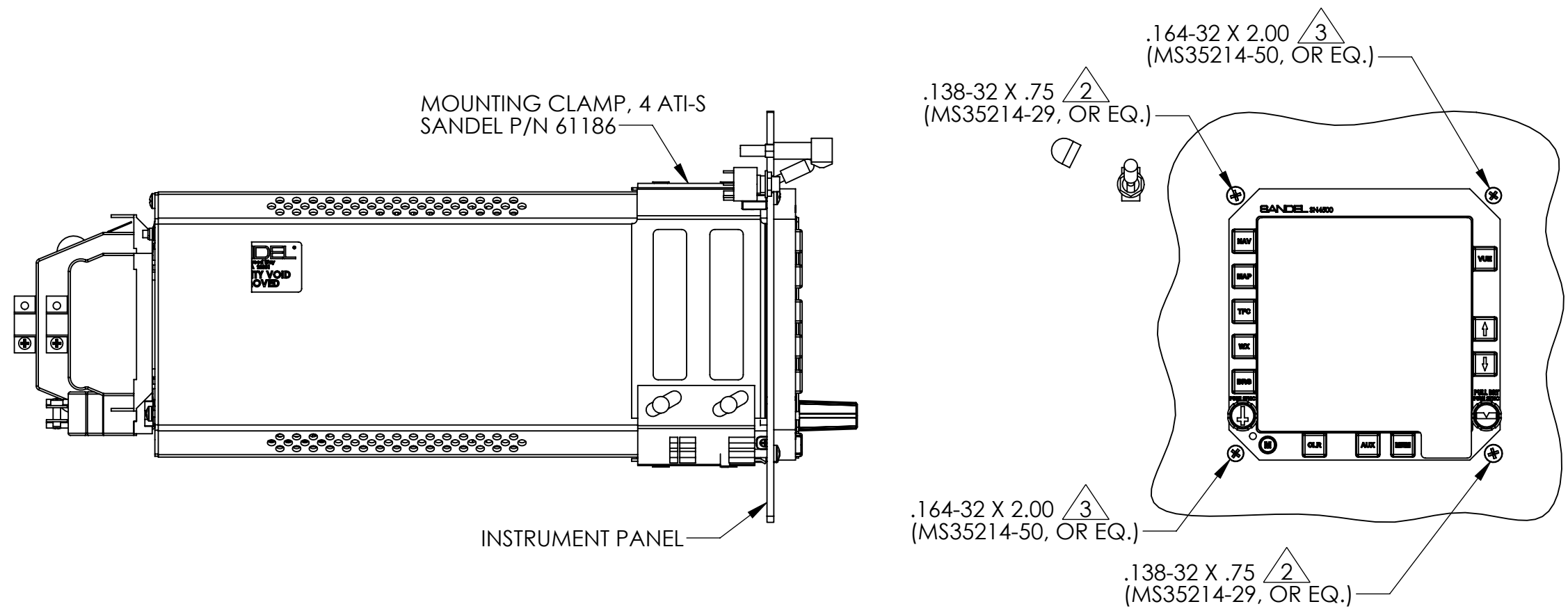

*CONFIDENTIAL: PROPRIETARY RIGHTS NOTICE: ALL RIGHTS RESERVED. THIS MATERIAL CONTAINS THE VALUABLE PROPERTIES AND TRADE SECRETS OF NIGHTHAWK FLIGHT SYSTEMS, INC. OF CALIFORNIA, UNITED STATES OF AMERICA, EMBODYING SUBSTANTIAL CREATIVE EFFORTS AND CONFIDENTIAL INFORMATION, IDEAS, AND EXPRESSIONS, NO PART OF WHICH MAY BE REPRODUCED OR TRANSMITTED IN ANY FORM OR BY ANY MEANS, ELECTRONIC, MECHANICAL OR OTHERWISE, INCLUDING PHOTOCOPYING AND RECORDING, OR IN CONNECTION WITH ANY INFORMATION STORAGE OR RETRIEVAL SYSTEM WITHOUT THE PERMISSION IN WRITING FROM NIGHTHAWK FLIGHT SYSTEMS, INC. COPYRIGHT AN UNPUBLISHED WORK. NIGHTHAWK FLIGHT SYSTEMS, INC.*

UNLESS OTHERWISE SPECIFIED DIMENSIONS ARE IN INCHES TOLERANCES ARE:

DECIMALS .XX ± .01 .XXX ± .005	ANGLES ±.5°
MATERIAL 3	FINISH 4
DO NOT SCALE DRAWING	

CAD GENERATED DRAWING, DO NOT MANUALLY UPDATE	
APPROVALS	DATE
DRAWN T. MORRISON	11/01/06
CHECKED M. WILEY	11/01/06
RESP ENG T. MORRISON	11/01/06
MFG ENG	
APPROVAL	

**NIGHTHAWK FLIGHT SYSTEMS, INC.** VISTA, CA

## LAYOUT, SN4500 INSTALLATION

SIZE B 3T1Z4	CAGE CODE 82009	DWG. NO. 05	REV. B1
SCALE 1:2 CAD FILE & NOTED 82009-05 SN4500 INSTALL SHEET 1 OF 2			

APPLICATION	SN4500
NEXT ASSY	USED ON



D

C

B

A

D

C

B

A

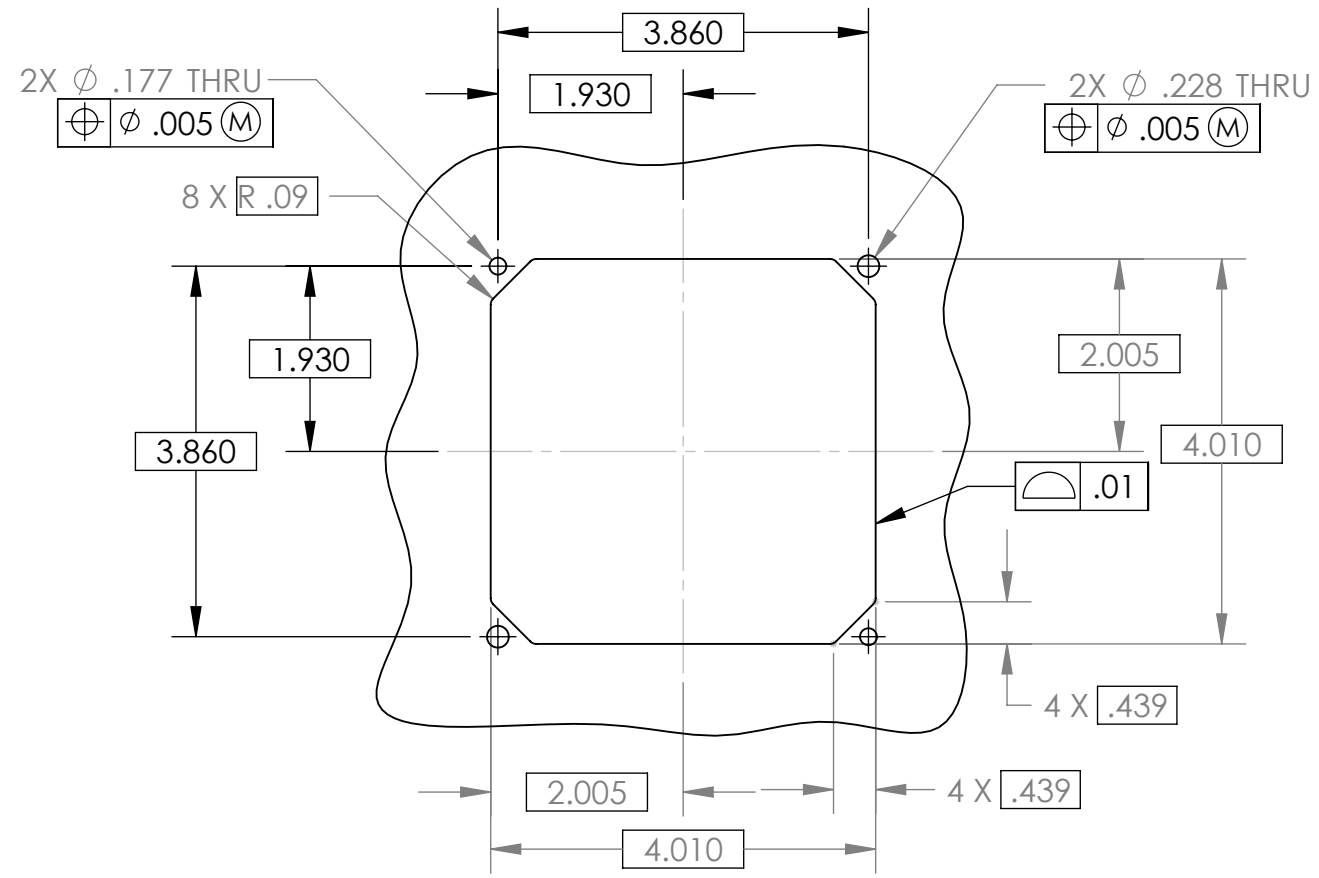

SUGGESTED PANEL CUT OUT  
 (REF. ARINC SPECIFICATION 408A)

DATE	REV	COMMENTS
02-09-06	A	INITIAL RELEASE
10-28-06	B	CHANGE NOTE 2, ref A/R 867

COMPUTER CONTROLLED DRAWING  
DO NOT REVISE MANUALLY

**SN4500 input power requires 22 to 33 VDC.**

**See Note 4.**

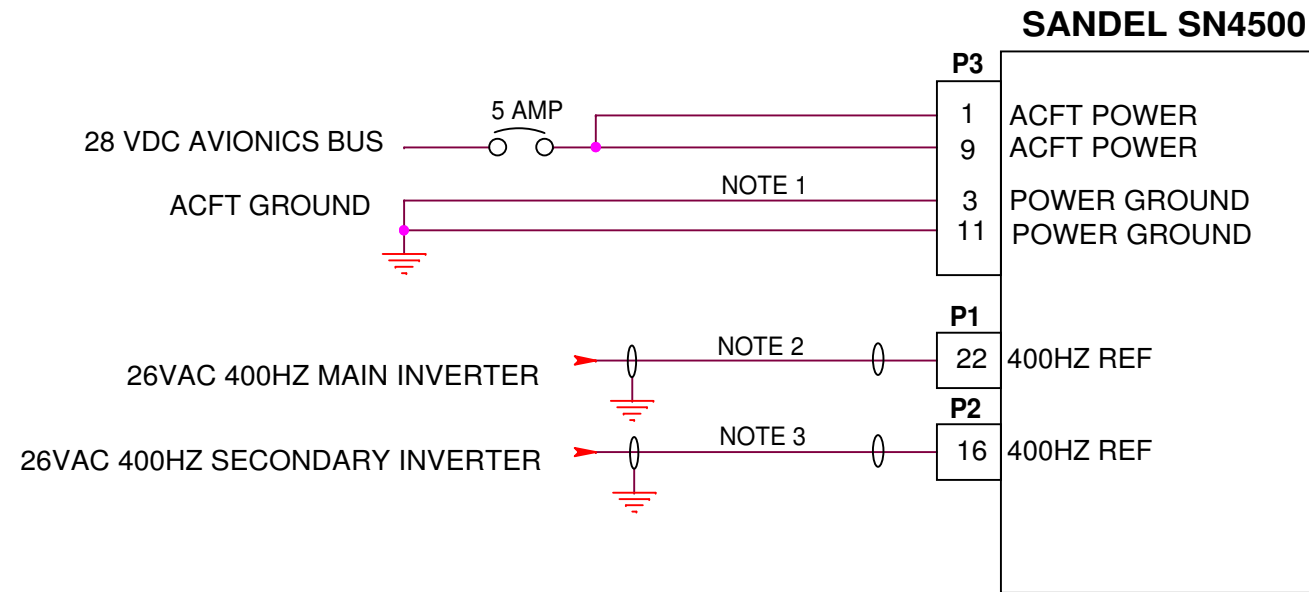

**NOTES:**

1. USE 20AWG WIRE FOR AIRCRAFT POWER (P3-1,P3-9) AND GROUND (P3-3, P3-11) CONNECTIONS.
2. INVERTER 1 IS REQUIRED IF AN XYZ GYRO OR XYZ ADF ARE CONNECTED TO P1, OR IF THE BOOTSTRAP SYNCHRO OUTPUT IS CONNECTED, OR IF AN INSTALLED AUTOPILOT USES AC COURSE AND HEADING DATUM WITH THE SIGNAL TYPE ON THE FCS MAINTENANCE PAGE SET TO AC AND THE EXTERNAL EXCITATION (P2-10) IS NOT USED.
3. INVERTER 2 IS REQUIRED WHEN AN XYZ ADF IS CONNECTED TO P2.
4. INSTALLATIONS IN 14V AIRCRAFT REQUIRE A 14V TO 28V CONVERTER. CONTACT SANDEL FOR COMPATIBLE MODELS.

<b>SANDEL</b> ®		Vista, Ca.
Category SN4500 INSTALLATION DRAWING		
Title <b>POWER AND INVERTER</b>		
Size B	Document Number <b>82009-10</b>	Rev <b>B</b>
Create:	Mod:	Sheet 1

DATE	REV	COMMENTS
02-09-06	A	INITIAL RELEASE
10-28-06	B	MODIFIED NOTES AND ADDED ALTERNATE FLAG SIGNAL CONNECTIONS FOR CLARITY. Ref A/R 867.

## BLOCK DIAGRAM SHOWS USE OF INTERNAL AUTOPILOT SWITCHING RELAY

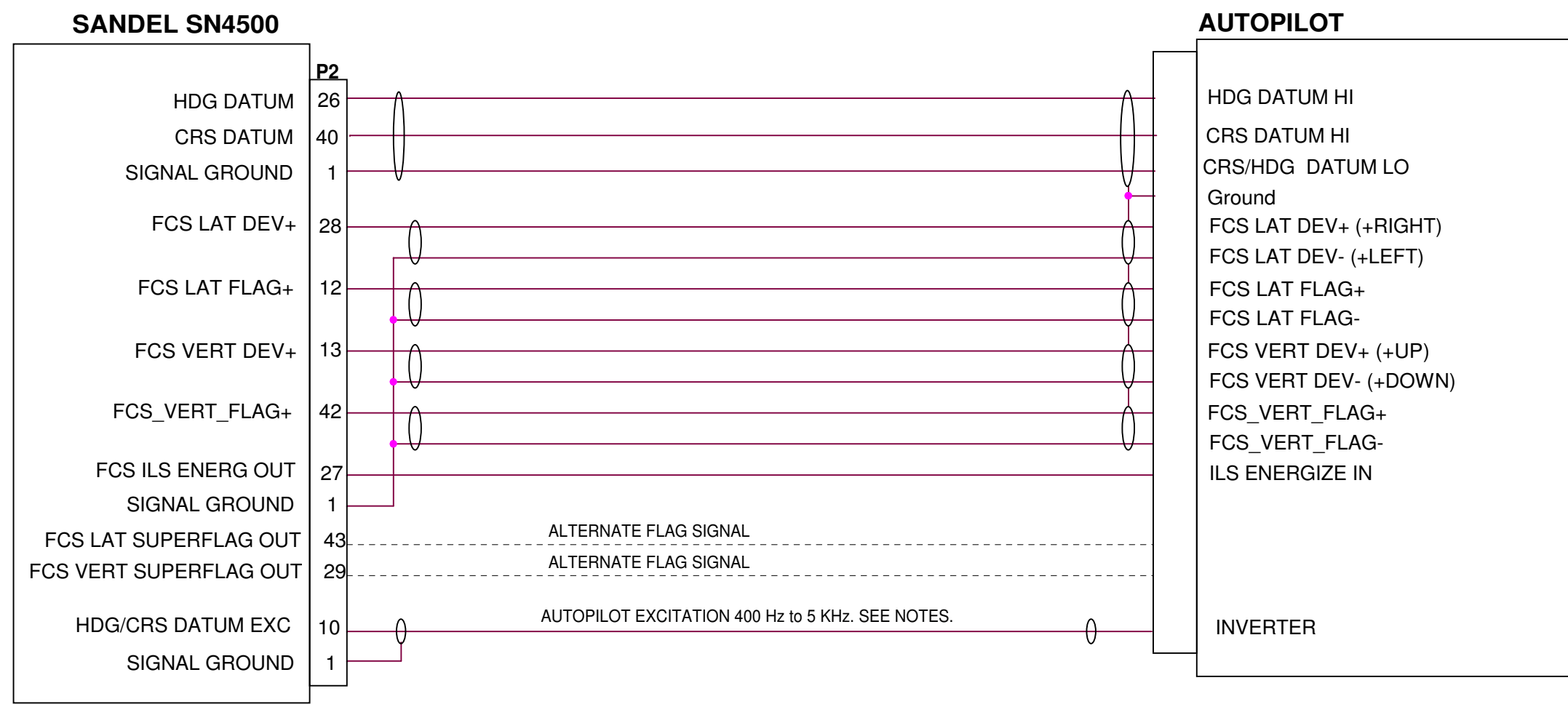

COMPUTER CONTROLLED DRAWING  
DO NOT REVISE MANUALLY

### NOTES:

1. IN THIS CONFIGURATION THE SN4500 PROVIDES THE AUTOPILOT SWITCHING RELAY FUNCTION FOR EACH NAV SOURCE CONNECTED.
2. THE CONNECTION TO P2-10 IS USED ONLY WHEN INTERFACING WITH AUTOPILOTS REQUIRING AC COURSE AND HEADING DATUM. IF USED, SELECT "EXCITATN > EXTRN" ON THE FCS MAINTENANCE PAGE.

<b>SANDEL</b> ®		Vista, Ca.
Category <b>SN4500 INSTALLATION DRAWING</b>		
Title <b>FCS DEVIATION (INT RELAY)</b>		
Size B	Document Number <b>82009-10</b>	Rev <b>B</b>
Create:	Mod:	Sheet 2

COMPUTER CONTROLLED DRAWING  
DO NOT REVISE MANUALLY

DATE	REV	COMMENTS
02-09-06	A	INITIAL RELEASE
10-28-06	B	REMOVED NOTE 3 WHICH REFERENCED SN3500. FORMAT CHANGE. Ref A/R 867.
03-07-22	C	REPLACED REFERENCE TO SN3500 WITH SN4500

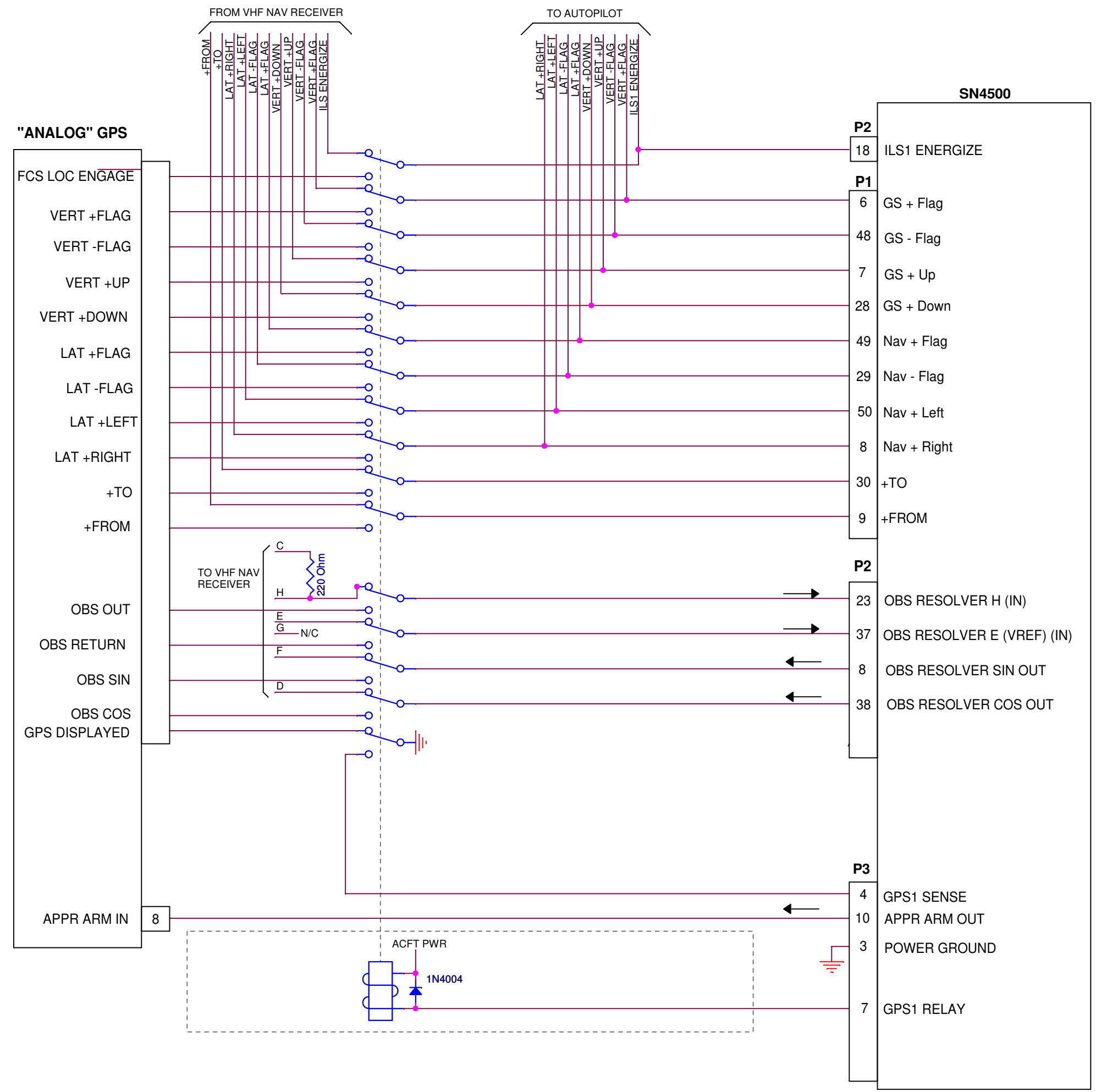

BLOCK DIAGRAM SHOWS USE OF EXTERNAL AUTOPILOT SWITCHING RELAY USING SN4500 CONVENTIONAL LOW LEVEL INPUTS

NOTES:

1. IN THIS CONFIGURATION THE SN4500 ACTS AS AN INDICATOR, FOLLOWING THE RECEIVER SELECTED WITH AN EXTERNAL RELAY.
2. THIS IS A GENERIC ILLUSTRATION. REFER TO THE SPECIFIC DETAIL DRAWINGS FOR YOUR INSTALLATION.

<b>SANDEL</b> ®		Vista, Ca.
Category	SN4500 INSTALLATION DRAWING	
Title	FCS DEVIATION (EXT RELAY)	
Size B	Document Number	Rev
	<b>82009-10</b>	<b>C</b>
Create:	Mod:	Sheet 3

DATE	REV	COMMENTS
02-09-06	A	INITIAL RELEASE
10-28-06	B	NOTE CORRECTION (SPELLING). Ref A/R 867.

COMPUTER CONTROLLED DRAWING  
DO NOT REVISE MANUALLY

### DC CRS/HDG DATUM TYPICAL INTERCONNECT

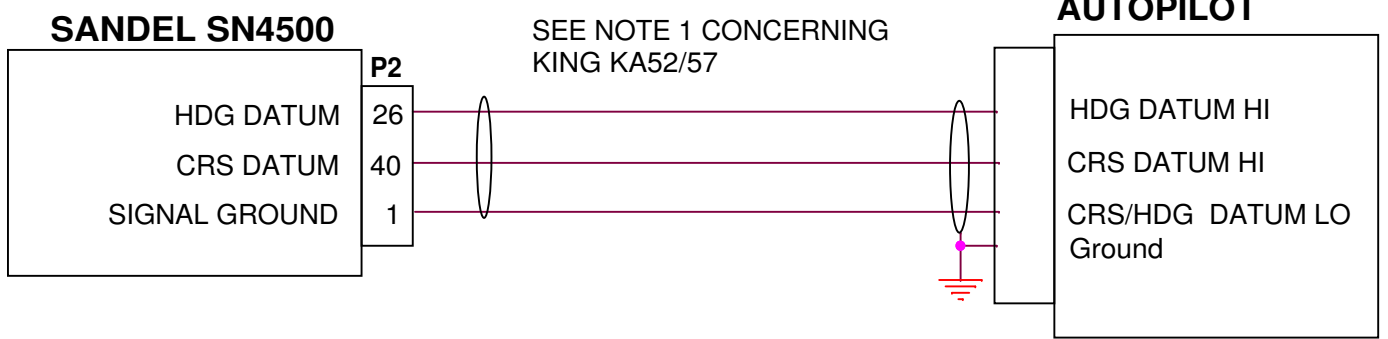

### AC AUTOPILOT TYPICAL INTERCONNECT

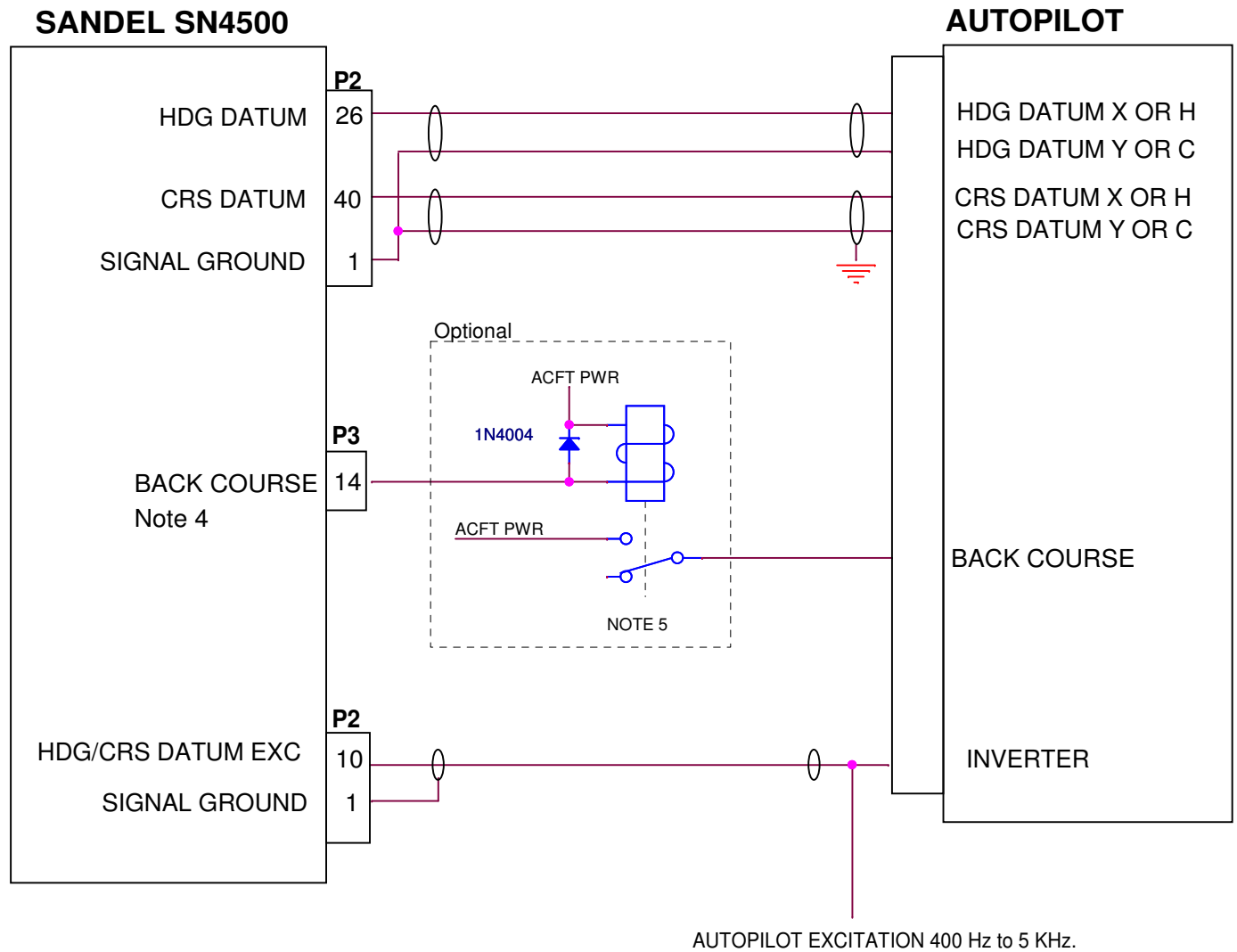

Note 3

**NOTES:**

- IF INSTALLATION ALREADY CONTAINS A KING KA52/57 AUTOPILOT ADAPTER IT MAY REMAIN IN THE SYSTEM. TREAT THE SN4500 AS A KI525.
- SN4500 DATUM OUTPUTS ARE REFERENCED TO SIGNAL GROUND.
- CHECK AUTOPILOT INTERNAL SCHEMATIC TO INSURE THAT THE SN4500 IS DRIVING THE SIGNAL INPUTS AND THAT IT IS PERMISSABLE TO GROUND 'C' OR 'Y' AS SHOWN. IN SOME CASES 'C' MAY BE SIGNAL AND 'H' MAY BE GROUND. CALL FACTORY WITH ANY QUESTIONS.
- WHEN BC OUTPUT NOT REQUIRED LEAVE UNCONNECTED.
- BC OUTPUT IS AN OPEN COLLECTOR. RELAY REQUIRED IF BACK COURSE INPUT TO AUTOPILOT REQUIRES +28V TO ACTIVATE. OTHERWISE CONNECT SN4500 BC OUTPUT DIRECTLY TO AUTOPILOT BC INPUT.
- IF CRS/HDG WORK BACKWARDS, CHANGE LEFT/RIGHT DATUM SETTING ON FCS EMULATION MAINTENANCE PAGE.

<b>SANDEL</b> ® Vista, Ca.	
Category	SN4500 INSTALLATION DRAWING
Title	FCS GENERIC CRS/HDG DATUM
Size B	Document Number <b>82009-10</b> Rev <b>B</b>
Create:	Mod: Sheet 4

DATE	REV	COMMENTS
02-09-06	A	INITIAL RELEASE
10-28-06	B	NOTE CORRECTIONS (SPELLING) AND FORMAT Ref A/R 867.

COMPUTER CONTROLLED DRAWING  
DO NOT REVISE MANUALLY

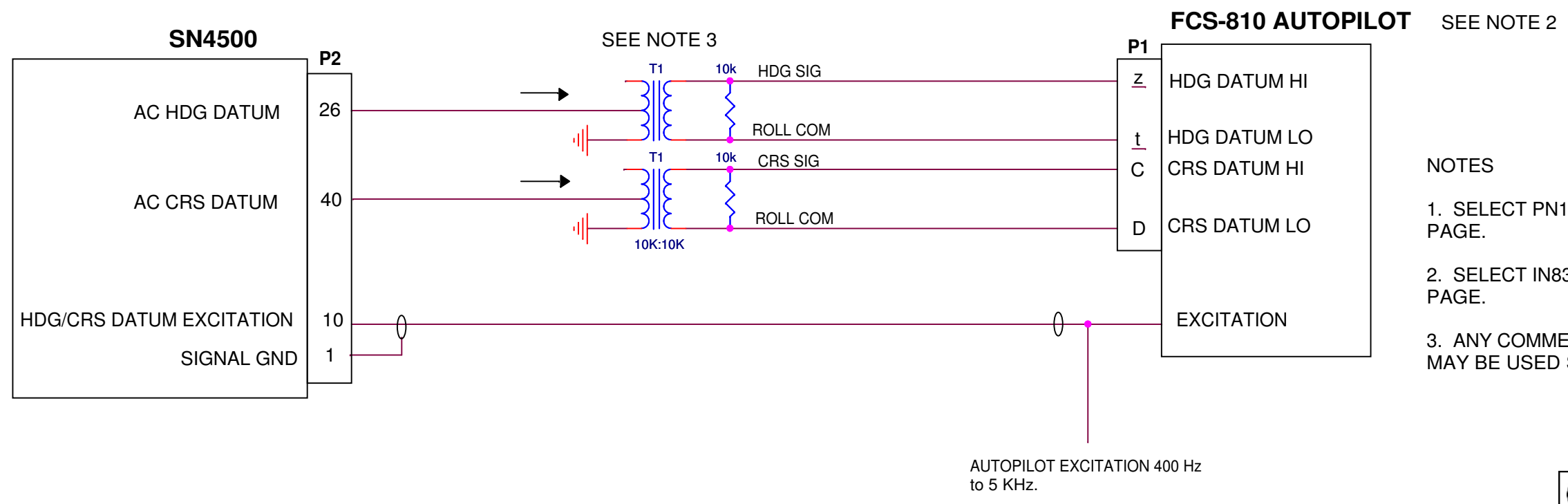
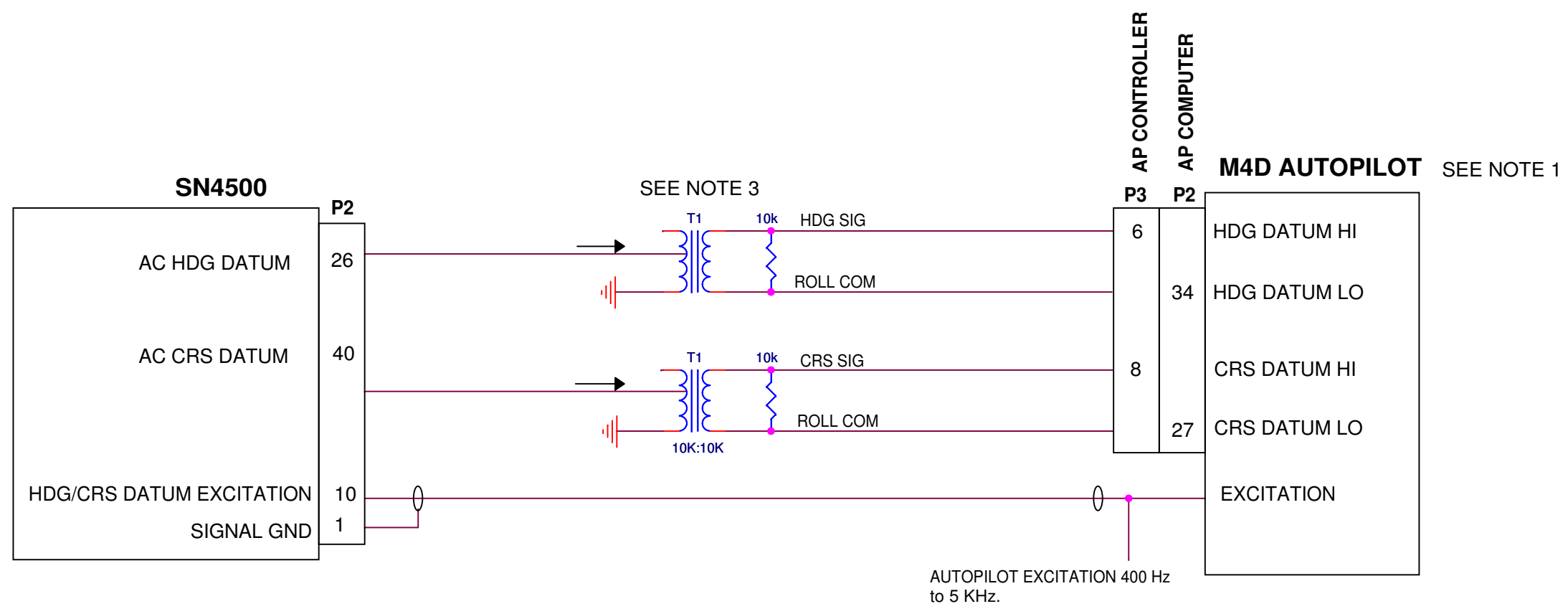

NOTES

1. SELECT PN101 FOR HSI EMULATION ON THE FCS MAINTENANCE PAGE.
2. SELECT IN831 FOR HSI EMULATION ON THE FCS MAINTENANCE PAGE.
3. ANY COMMERCIAL 75MW OR GREATER AUDIO TRANSFORMERS MAY BE USED SUCH AS MAGNA-TEK TY-141P OR EQUIVALENT

<b>SANDEL</b> ®		Vista, Ca.
Category	SN4500 INSTALLATION DRAWING	
Title	BENDIX AUTOPILOTS	
Size B	Document Number	Rev
	<b>82009-10</b>	<b>B</b>
Create:	Mod:	Sheet 5

DATE	REV	COMMENTS
02-09-06	A	INITIAL RELEASE
10-28-06	B	ADDED NOTE 2. Ref A/R 867.

COMPUTER CONTROLLED DRAWING  
DO NOT REVISE MANUALLY

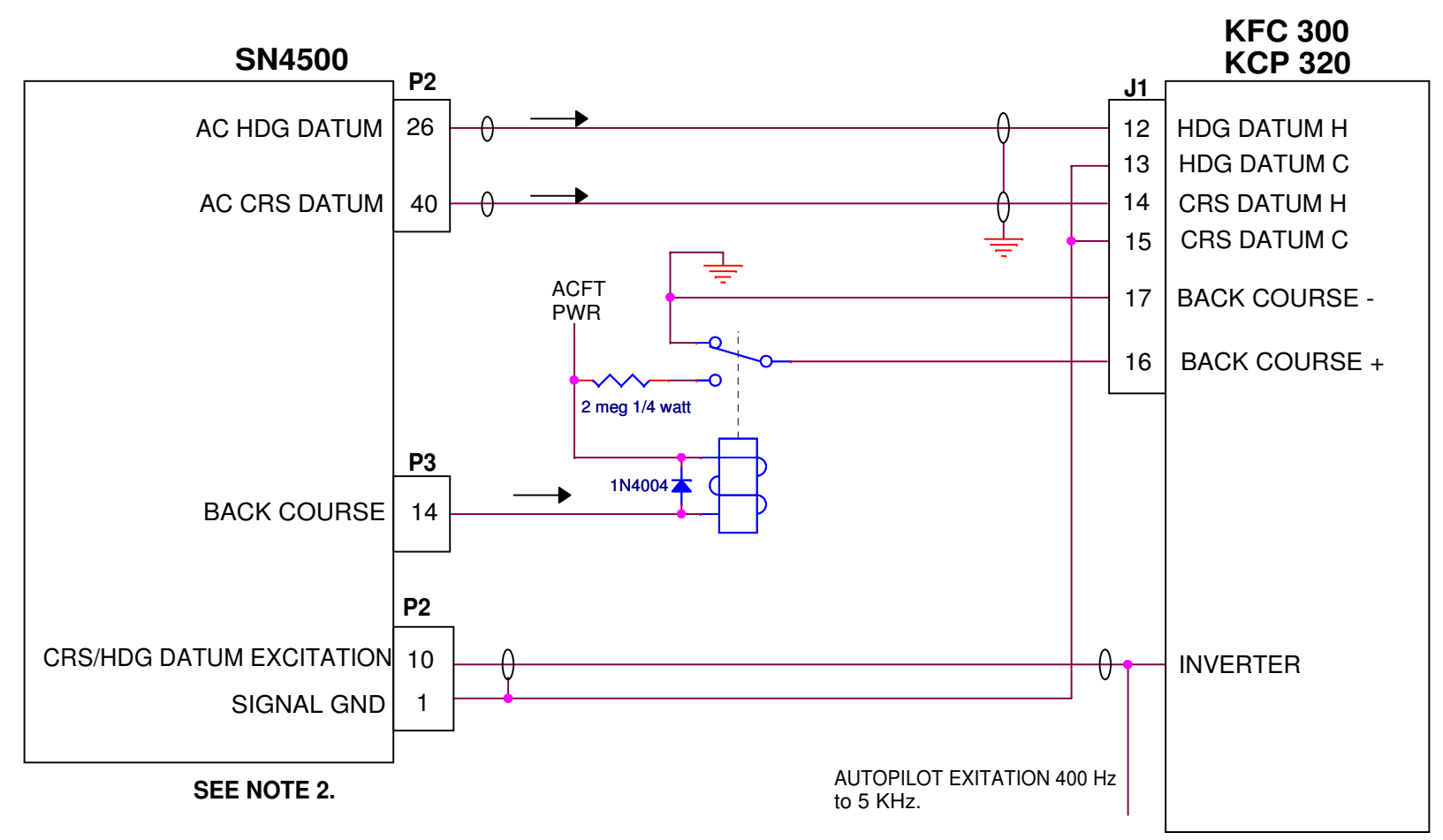
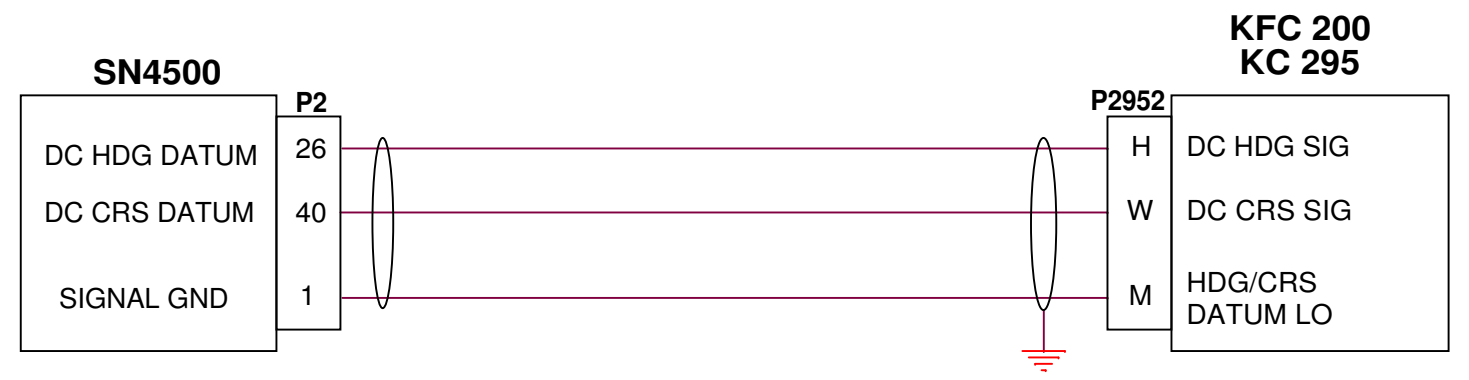
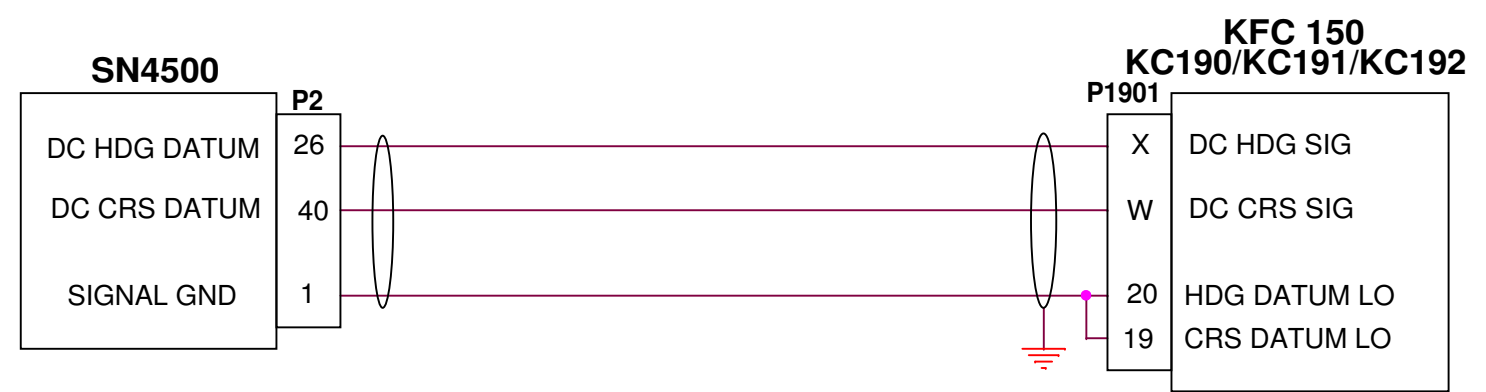

SEE NOTE 2.

NOTES:

1. SELECT "KI525" FOR HSI EMULATION ON THE FCS MAINTENANCE PAGE.
2. SELECT "PN101" FOR HSI EMULATION ON THE FCS MAINTENANCE PAGE.

**SANDEL**® Vista, Ca.

Category: SN4500 INSTALLATION DRAWING

Title: BENDIX/KING AUTOPILOTS

Size B Document Number: **82009-10** Rev **B**

Create: Mod: Sheet 6

DATE	REV	COMMENTS
02-09-06	A	INITIAL RELEASE

COMPUTER CONTROLLED DRAWING  
DO NOT REVISE MANUALLY

### CENTURY IV INTERCONNECT (5KHZ AC VERSION)

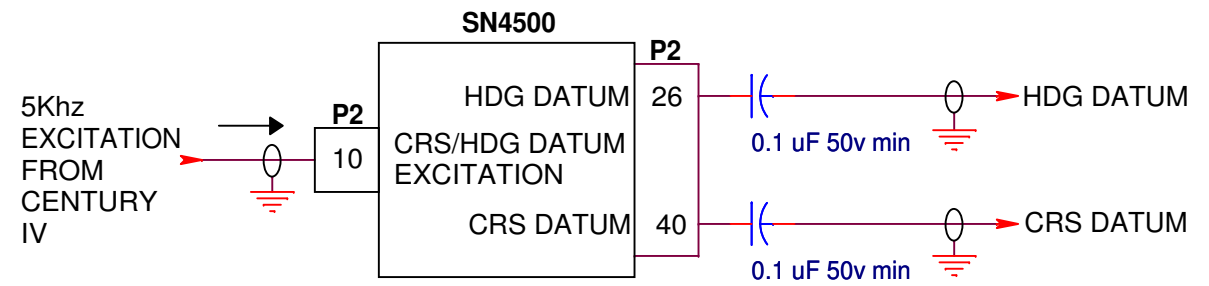

NOTES 1 & 2

### CENTURY IV INTERCONNECT (DC VERSION)

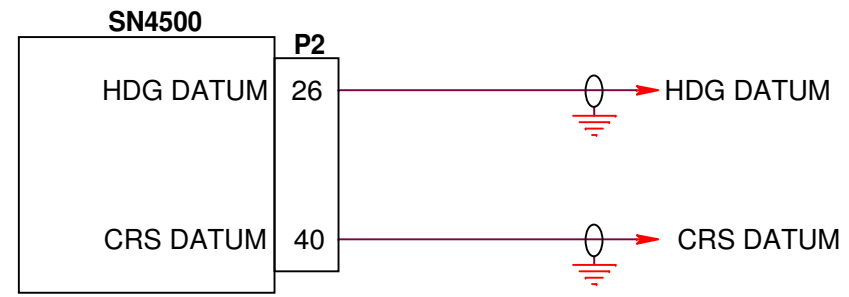

NOTES 1 & 2

NOTES:

1. SELECT NSD-360DC ON FCS EMULATION MAINTENANCE PAGE.
2. ON FCS-EMULATION MAINTENANC PAGE, ADJUST HDG-GRADIENT (AND CRS-GRADIENT IF USED) TO HIGHEST VALUE THAT DOES NOT OVER-SHOOT THE LUBBER LINE DURING HDG-MODE AND NAV-MODE COURSE CHANGES RESPECTIVELY. EXCEPT FOR KI-525 THESE VALUES WILL BE IDENTICAL.

<b>SANDEL</b> ®		Vista, Ca.
Category	SN4500 INSTALLATION DRAWING	
Title	CENTURY IV AUTOPILOTS	
Size B	Document Number	Rev
	<b>82009-10</b>	<b>A</b>
Create:	Mod:	Sheet 7



DATE	REV	COMMENTS
02-09-06	A	INITIAL RELEASE

COMPUTER CONTROLLED DRAWING  
DO NOT REVISE MANUALLY

### CENTURY 1C-388 & 1C388-M RADIO COUPLERS

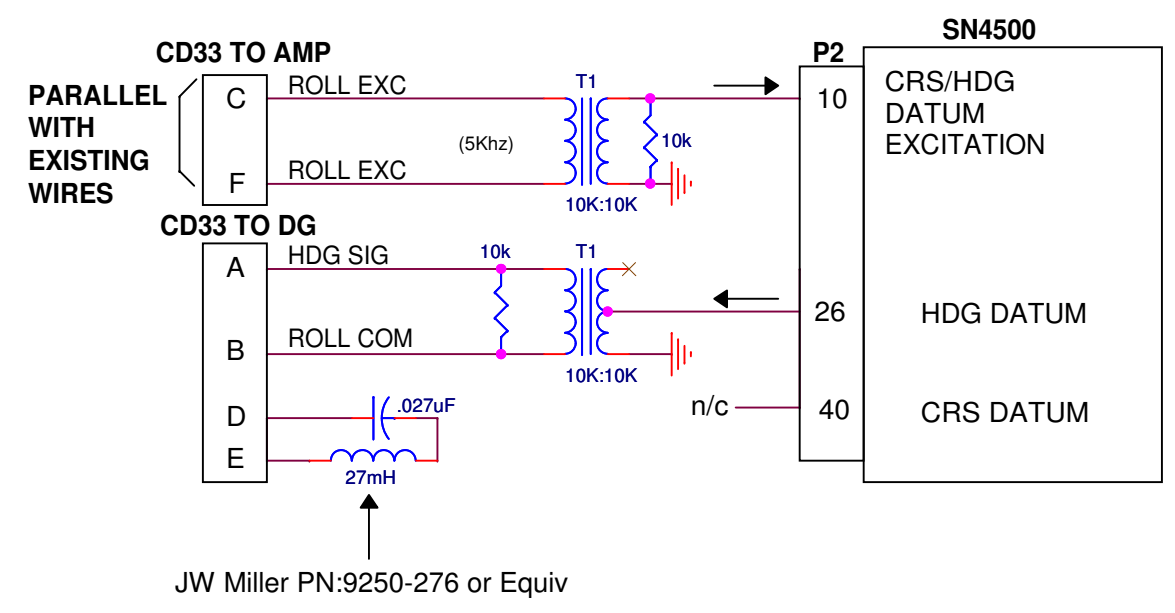

### CENTURY 1C-388-2 RADIO COUPLER

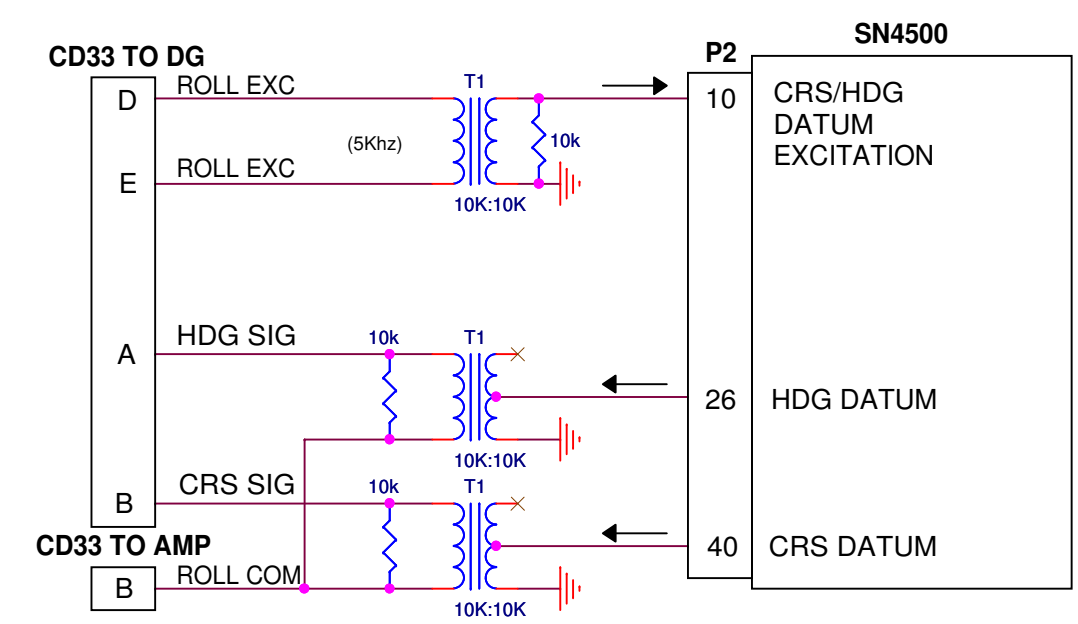

### CENTURY 1C-388-C, 1C388-MC RADIO COUPLERS

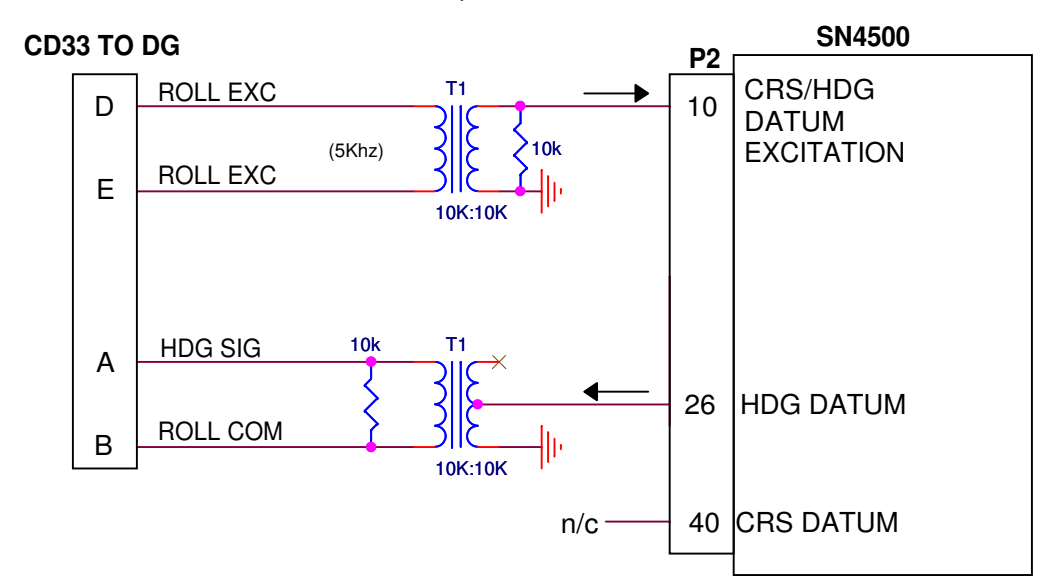

**(ABOVE COUPLERS DO NOT SUPPORT COURSE DATUM.)**

### CENTURY 1C-388-3 RADIO COUPLER

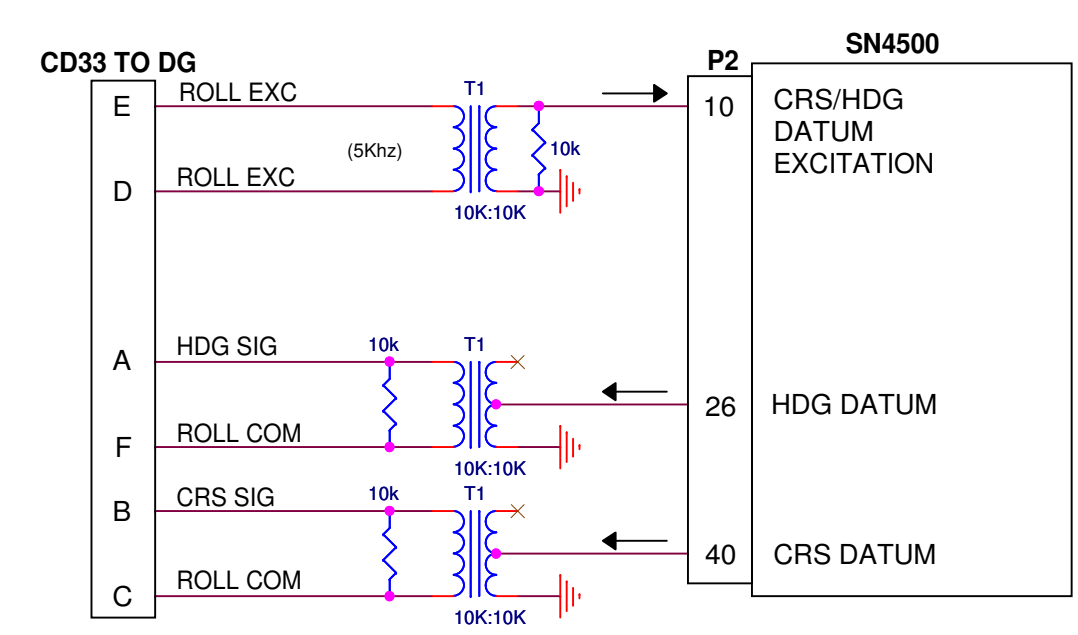

**NOTES:**

1. SELECT NSD-360DC ON THE FCS MENU.
2. ON FCS EMULATION MAINTENANCE PAGE, ADJUST HDG-GRADIENT (AND CRS-GRADIENT IF USED) TO HIGHEST VALUE THAT DOES NOT OVER-SHOOT THE LUBBER LINE DURING HDG-MODE AND NAV-MODE COURSE CHANGES RESPECTIVELY. NORMALLY THESE VALUES WILL BE THE SAME.
3. GROUND CONNECTIONS TO SN4500 SIGNAL GROUND.
4. DO NOT GROUND ANY CENTURY II/III SIGNALS EVEN DURING TROUBLESHOOTING. THIS COULD DAMAGE THE AUTOPILOT. SEE THE CENTURY INSTALLATION MANUAL FOR DETAILS.
5. ANY COMMERCIAL 75MW OR GREATER AUDIO TRANSFORMERS MAY BE USED. MAGNA-TEK TY-141P OR EQUIVALENT.

<b>SANDEL</b> ® Vista, Ca.	
Category	SN4500 INSTALLATION DRAWING
Title	CENTURY 1C388 COUPLERS
Size B	Document Number <b>82009-10</b>
Rev	<b>A</b>
Create:	Mod: Sheet 8

DATE	REV	COMMENTS
02-09-06	A	INITIAL RELEASE

### S-TEC AUTOPILOTS

COMPUTER CONTROLLED DRAWING  
DO NOT REVISE MANUALLY

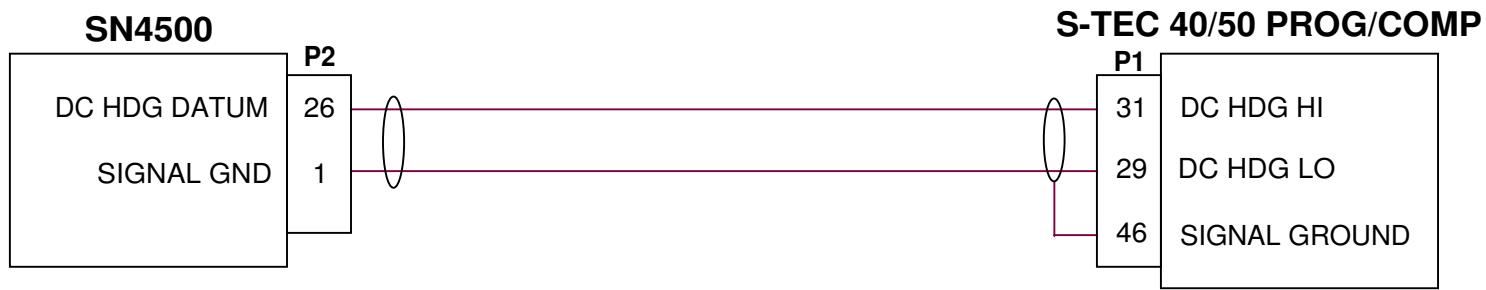
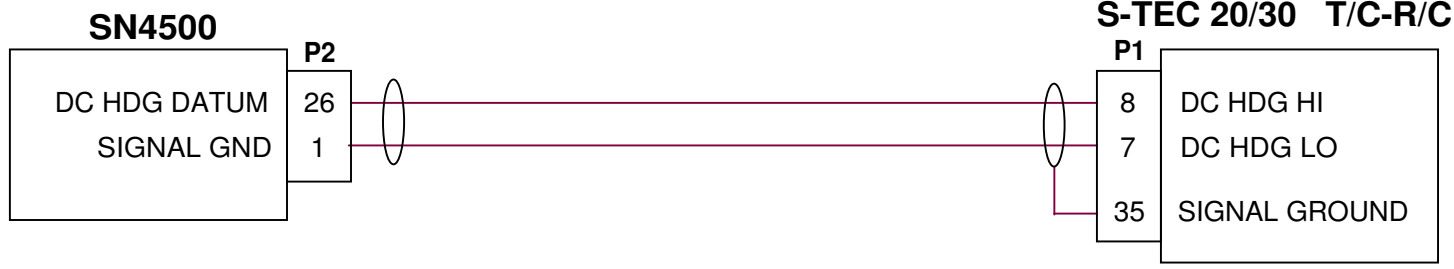

### S-TEC GPSS HEADING SYSTEM'S

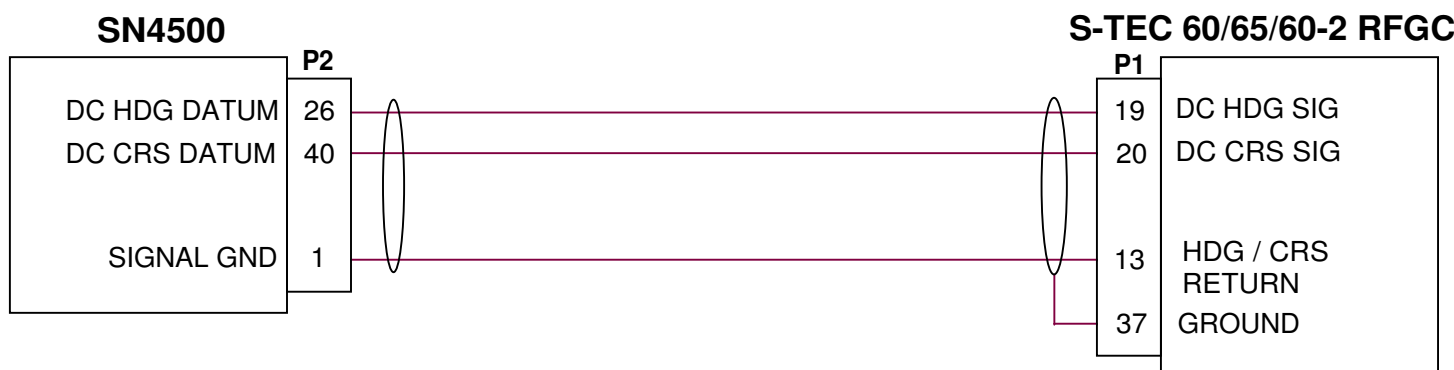
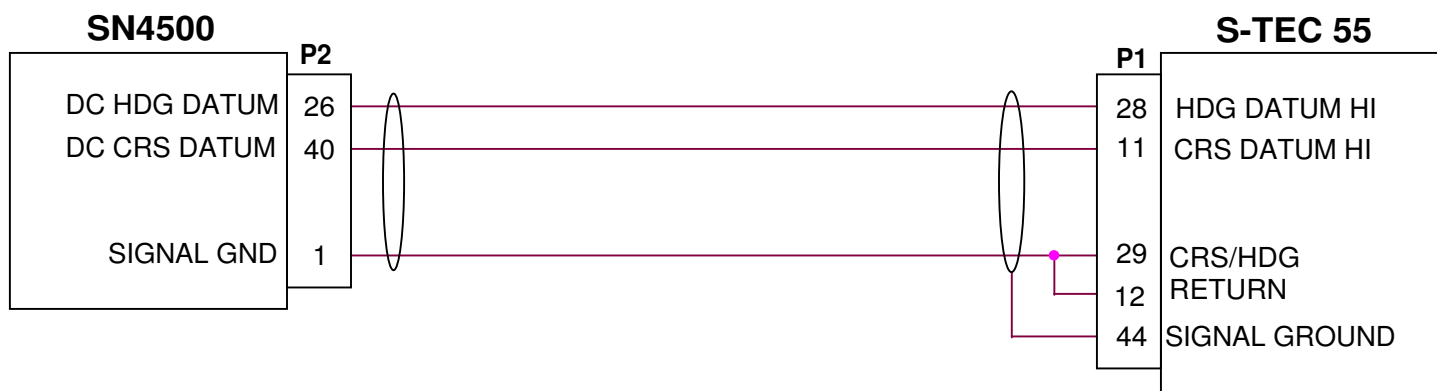
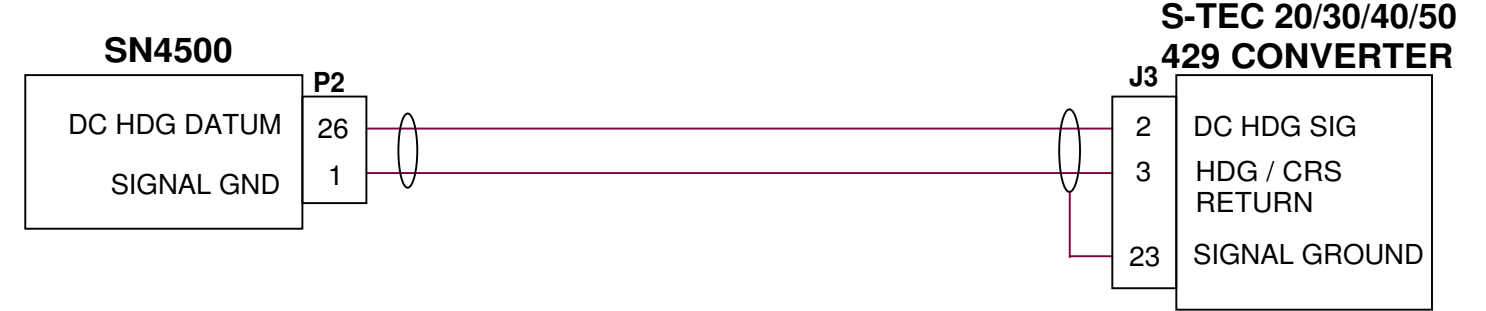

#### NOTES

1. SELECT KI525 FOR HSI EMULATION ON THE FCS MAINTENANCE PAGE.

<b>SANDEL</b> ®		Vista, Ca.
Category SN4500 INSTALLATION DRAWING		
Title S-TEC AUTOPILOTS		
Size B	Document Number	Rev A
	<b>82009-10</b>	
Create:	Mod:	Sheet 9

DATE	REV	COMMENTS
02-09-06	A	INITIAL RELEASE
10-28-06	B	ADDED KG102 SLAVING CONNECTION. Ref A/R 867.

COMPUTER CONTROLLED DRAWING  
DO NOT REVISE MANUALLY

### SANDEL SN4500

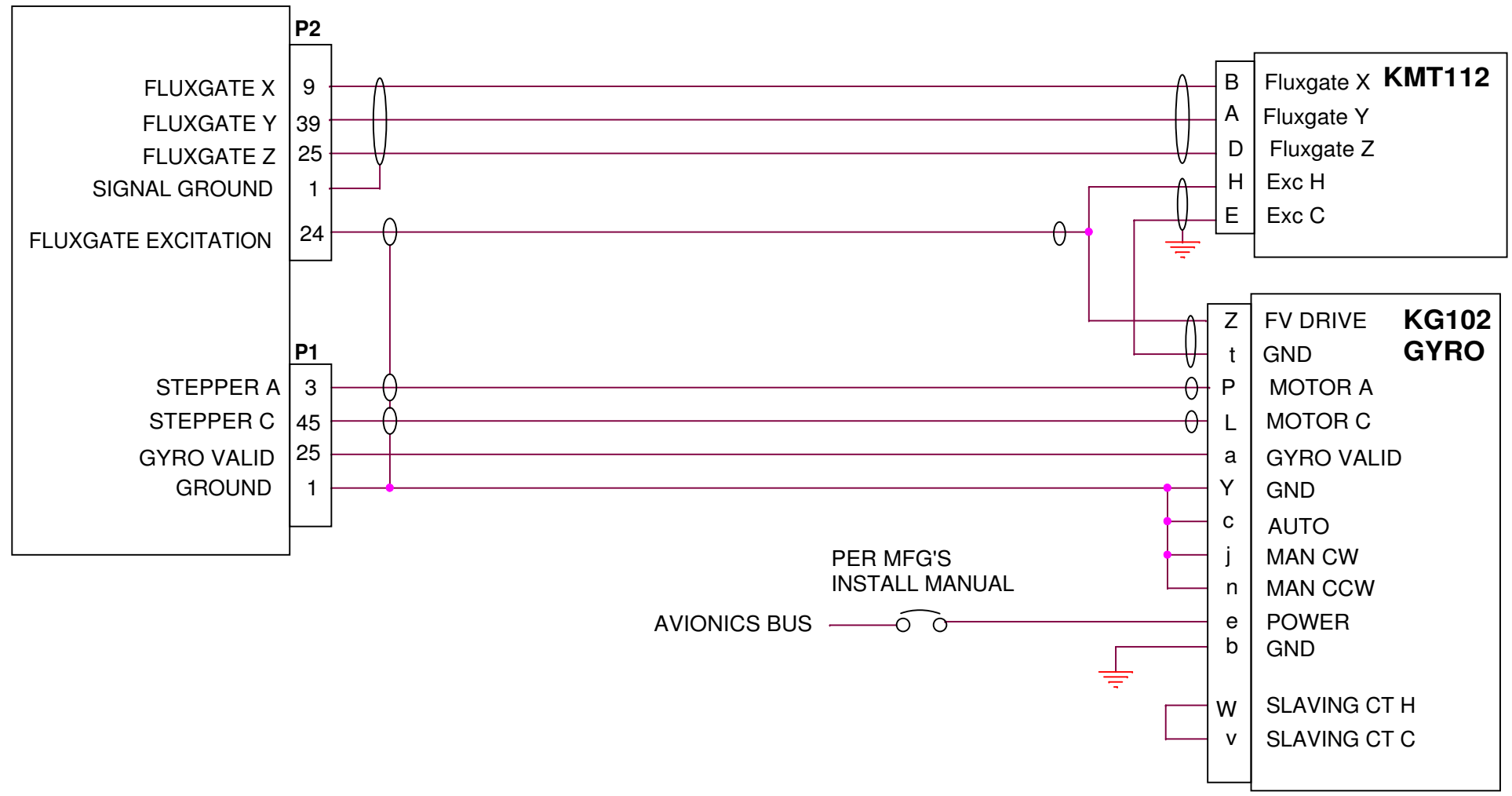

<b>SANDEL</b> ®		Vista, Ca.
Category SN4500 INSTALLATION DRAWING		
Title KING KG102A - SN4500 SLAVING		
Size B	Document Number <b>82009-10</b>	Rev <b>B</b>
Create:	Mod:	Sheet 10

DATE	REV	COMMENTS
02-09-06	A	INITIAL RELEASE

COMPUTER CONTROLLED DRAWING  
DO NOT REVISE MANUALLY

**BENDIX/KING KI525A BOOTSTRAP MASTER  
WITH NO INTERNAL SN4500 SLAVING.  
(NOTES 1 AND 2)**

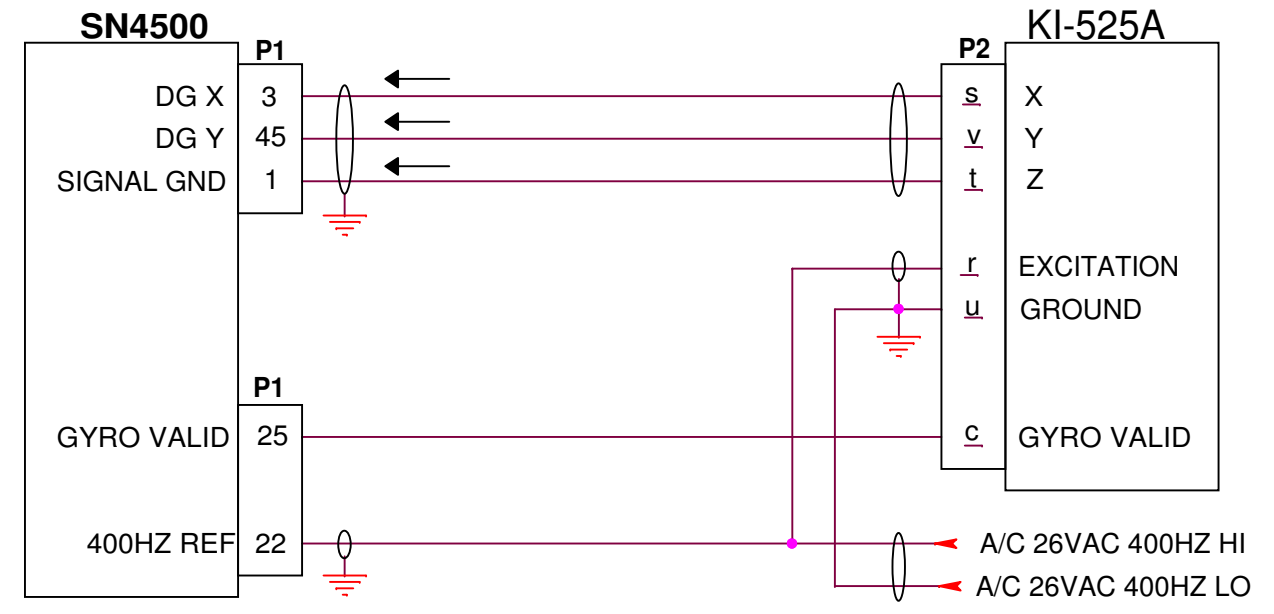

1. SELECT NONE FOR FLUXGATE TYPE.
2. THIS CONFIGURATION IS USED WHEN BOOTSTRAPPED FROM AN EXISTING KCS55 SLAVED COMPASS SYSTEM. THIS MIGHT BE DESIRED WHERE AN EXISTING IS MOVED TO THE COPILOTS SIDE AND AN SN4500 IS INSTALLED ON THE PILOTS SIDE. UNDER THIS CONDITION THE SN4500 CAN BE DRIVEN BY THE BOOTSTRAP OUTPUT OF THE COPILOTS HSI.

<b>SANDEL</b> ®		Vista, Ca.
Category	SN4500 INSTALLATION DRAWING	
Title	KCS55 - BOOSTRAP XYZ	
Size B	Document Number	Rev
	<b>82009-10</b>	<b>A</b>
Create:	Mod:	Sheet 11

DATE	REV	COMMENTS
02-09-06	A	INITIAL RELEASE
10-28-06	B	ADDED DC BLOCKING CAP AND NOTE 4. Ref A/R 867.

COMPUTER CONTROLLED DRAWING  
DO NOT REVISE MANUALLY

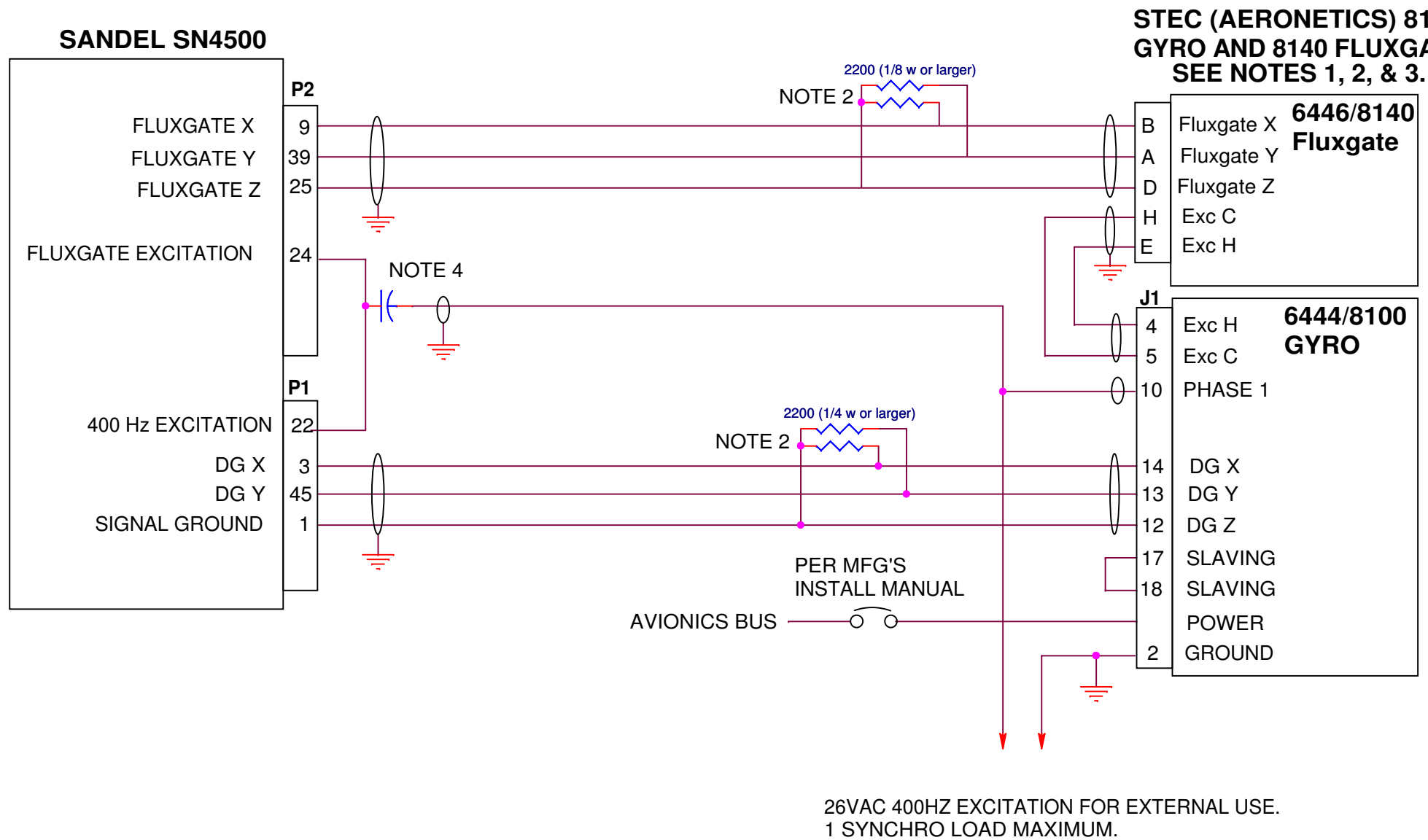

NOTES

1. THE STEC/AERONETICS GYRO DOES NOT ALLOW THE USE OF AN EXTERNAL 400HZ INVERTER FOR ITS XYZ OUTPUTS. IF AN EXTERNAL INVERTER IS NEEDED TO DRIVE OTHER SYSTEMS WHICH ARE CONNECTED TO THE SN4500, THIS GYRO IS NOT COMPATIBLE.
2. THE 2200 OHM RESISTORS ARE RECOMMENDED (NOT REQUIRED) TO REDUCE RINGING FROM THE INTERNAL INVERTER. THE SN4500 APPLIES NO LOAD TO THE GYRO.
3. EARLY MODELS OF AERONETICS GYROS OPERATE AT 600HZ AND ARE NOT COMPATIBLE WITH THIS SYSTEM. CONTACT STEC FOR S/N INFORMATION.
4. ADD A 0.1uf CAPACITOR TO BLOCK ANY DC COMPONENT THAT MAY BE PRESENT ON THE 26 VAC LINE.

**SANDEL**® Vista, Ca.

Category: SN4500 INSTALLATION DRAWING

Title: S-TEC (AERONETICS) GYRO

Size B Document Number **82009-10** Rev **B**

Create: Mod: Sheet 12

DATE	REV	COMMENTS
02-09-06	A	INITIAL RELEASE

COMPUTER CONTROLLED DRAWING  
DO NOT REVISE MANUALLY



NOTE 1

NOTES:

1. SELECT NONE FOR FLUXGATE TYPE.

<b>SANDEL</b> <sup>®</sup>		Vista, Ca.
Category	SN4500 INSTALLATION DRAWING	
Title	XYZ GYRO (GYRO SELF SLAVED)	
Size B	Document Number	Rev
	<b>82009-10</b>	<b>A</b>
Create:	Mod:	Sheet 13

DATE	REV	COMMENTS
02-09-06	A	INITIAL RELEASE
10-28-06	B	FORMAT CHANGE. Ref A/R 867.

COMPUTER CONTROLLED DRAWING  
DO NOT REVISE MANUALLY

**TYPICAL XYZ DG AND 26VAC FLUX GATE USING THE SN4500 INTERNAL SLAVING.**

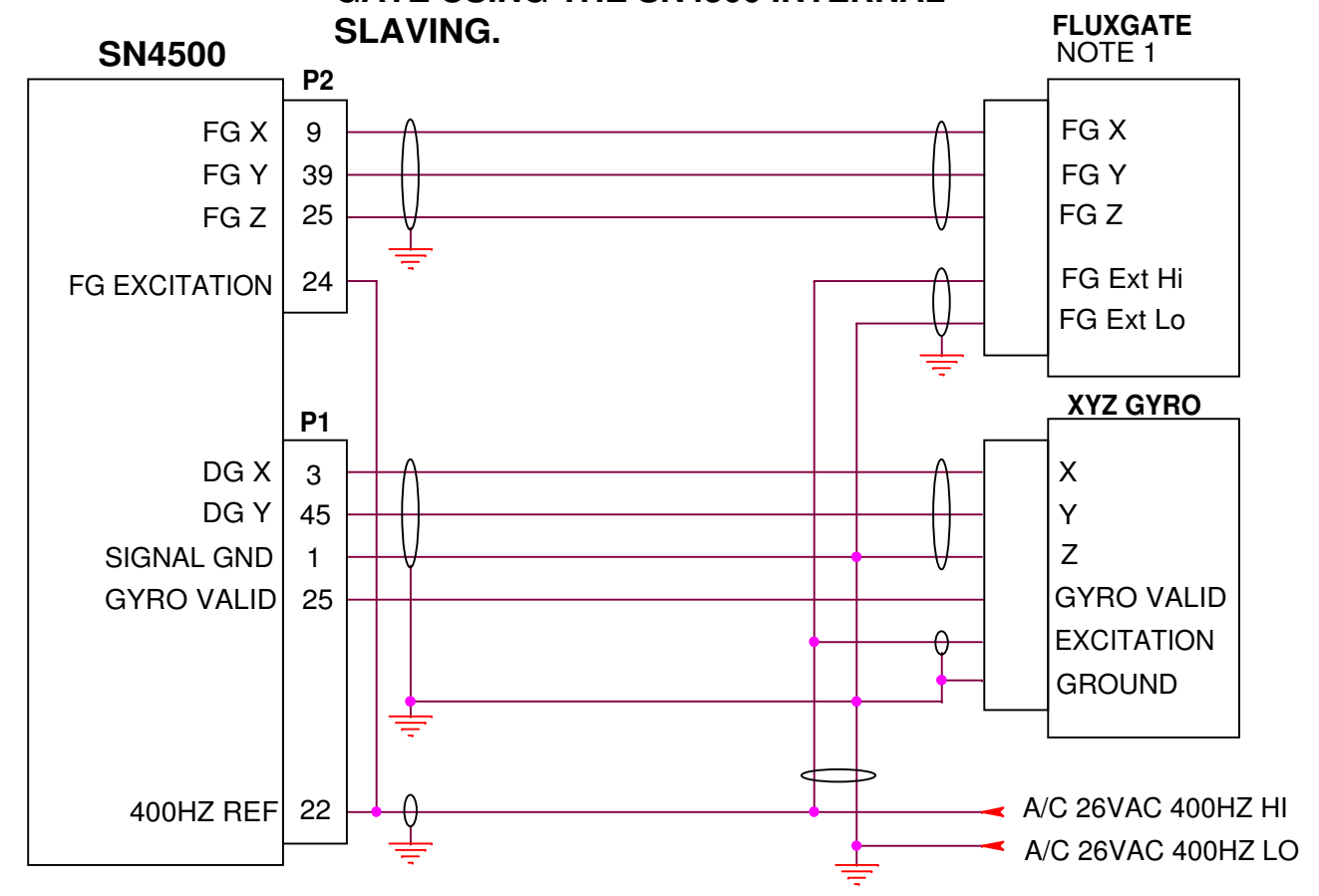

NOTES:

1. ANY TSO'D XYZ FLUX GATE IS PERMISSABLE, INSTALL ACCORDING TO MANUFACTURERS RECOMMENDATION. IF FLUX GATE REQUIRES LESS THAN 26VAC USE A PAIR OF SERIES RESISTORS (2 WATT) ONE IN EACH DRIVE LEAD TO PROVIDE THE CORRECT DRIVE VOLTAGE.

<b>SANDEL</b> ®		Vista, Ca.
Category	SN4500 INSTALLATION DRAWING	
Title	XYZ GYRO	
Size B	Document Number	Rev
	<b>82009-10</b>	<b>B</b>
Create:	Mod:	Sheet 14

DATE	REV	COMMENTS
02-09-06	A	INITIAL RELEASE
10-28-06	B	FORMAT CHANGE. Ref A/R 867.

COMPUTER CONTROLLED DRAWING  
DO NOT REVISE MANUALLY

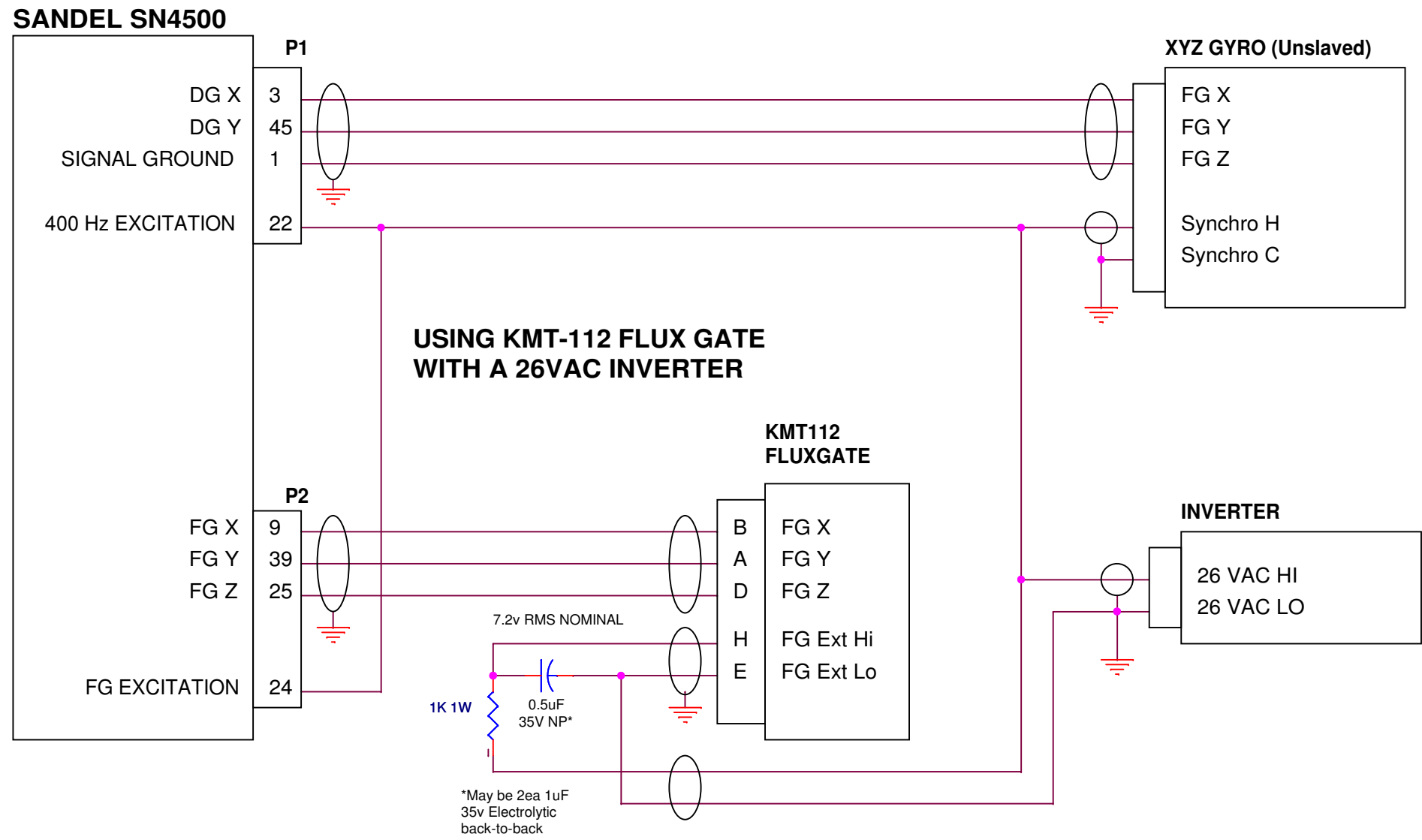

**SANDEL**® Vista, Ca.

Category: SN4500 INSTALLATION DRAWING

Title: XYZ GYRO WITH KMT112

Size B | Document Number: **82009-10** | Rev: **B**

Create: | Mod: | Sheet 15



DATE	REV	COMMENTS
02-09-06	A	INITIAL RELEASE
10-28-06	B	FORMAT CHANGE. Ref A/R 867.

COMPUER CONTROLLED DRAWING  
DO NOT REVISE MANUALLY

**LEAVING INSTALLED BUT BYPASSING THE SLAVING FUNCTION OF THE COLLINS 328A-3G SLAVING ACCESSORY WHEN UPGRADING A PN101 SYSTEM. SEE NOTES**

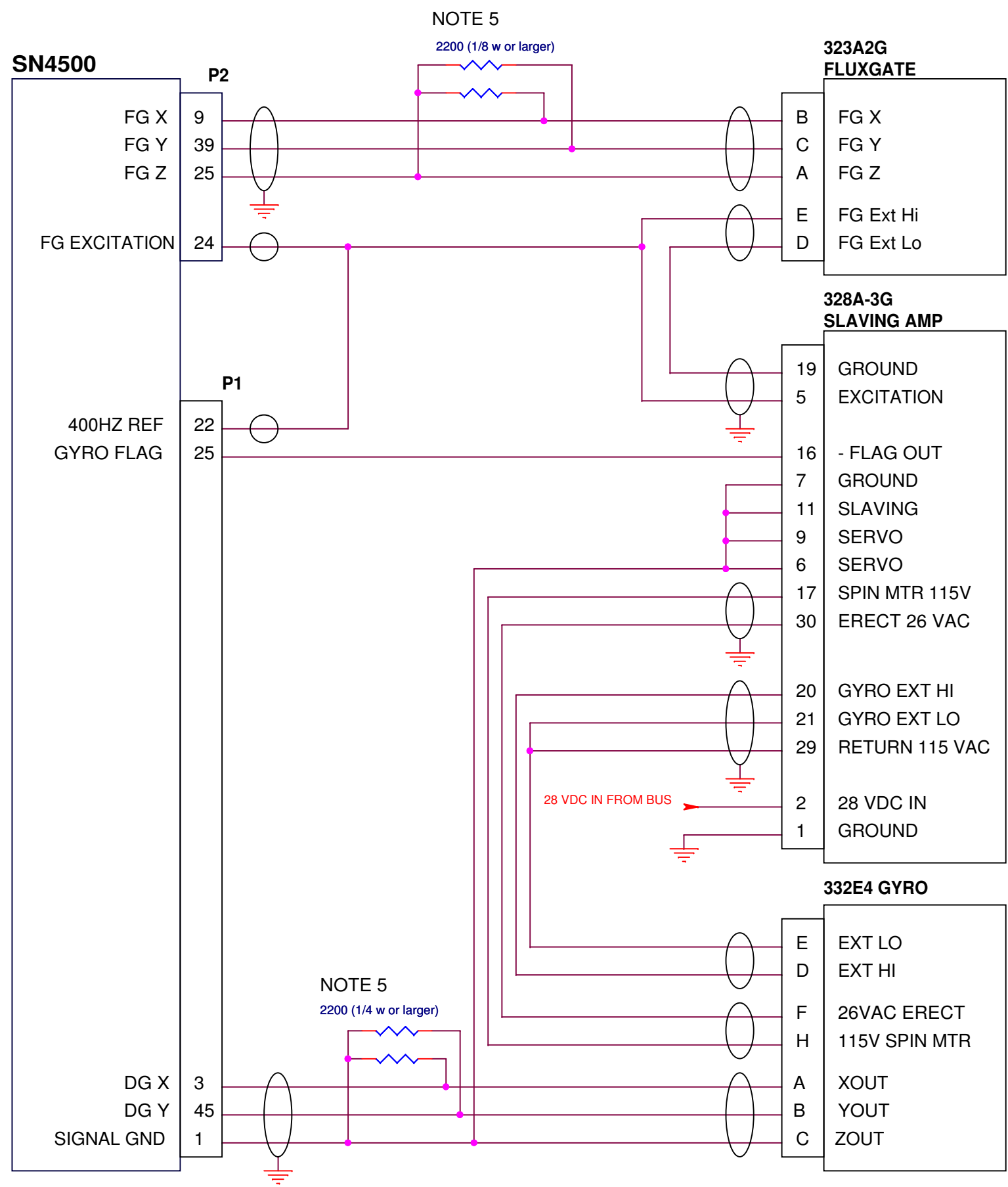

**NOTES**

1. THIS CONFIGURATION DOES NOT ALLOW FOR AN ADDITIONAL INVERTER DRIVING THE SN4500.
2. THIS CONFIGURATION DISABLES THE 328A-3G SLAVING ACTION. SLAVING IS PERFORMED INSIDE THE SN4500.
3. THE 328A-3G PROVIDES A HEADING FLAG OUTPUT TO THE SN4500.
4. THIS CONFIGURATION ALLOWS THE USE OF A COLLINS 332-E4 WITHOUT USING THE SLAVING FUNCTION OF THE 328A-3G SLAVING ACCESSORY.
5. THE 2200 OHM RESISTORS ARE RECOMMENDED (NOT REQUIRED) TO REDUCE RINGING FROM THE INTERNAL INVERTER. THE SN4500 APPLIES NO LOAD TO THE GYRO.
6. YOU MUST REMOVE THE 323A-3G FLUX COMPENSATOR LOCATED ON TOP OF THE FLUX VALVE.

**SANDEL**® Vista, Ca.

Category: SN4500 INSTALLATION DRAWING

Title: COLLINS PN101 UPGRADE

Size B Document Number **82009-10** Rev **B**

Create: Mod: Sheet 16

DATE	REV	COMMENTS
02-09-08	A	INITIAL RELEASE

COMPUTER CONTROLLED DRAWING  
DO NOT REVISE MANUALLY

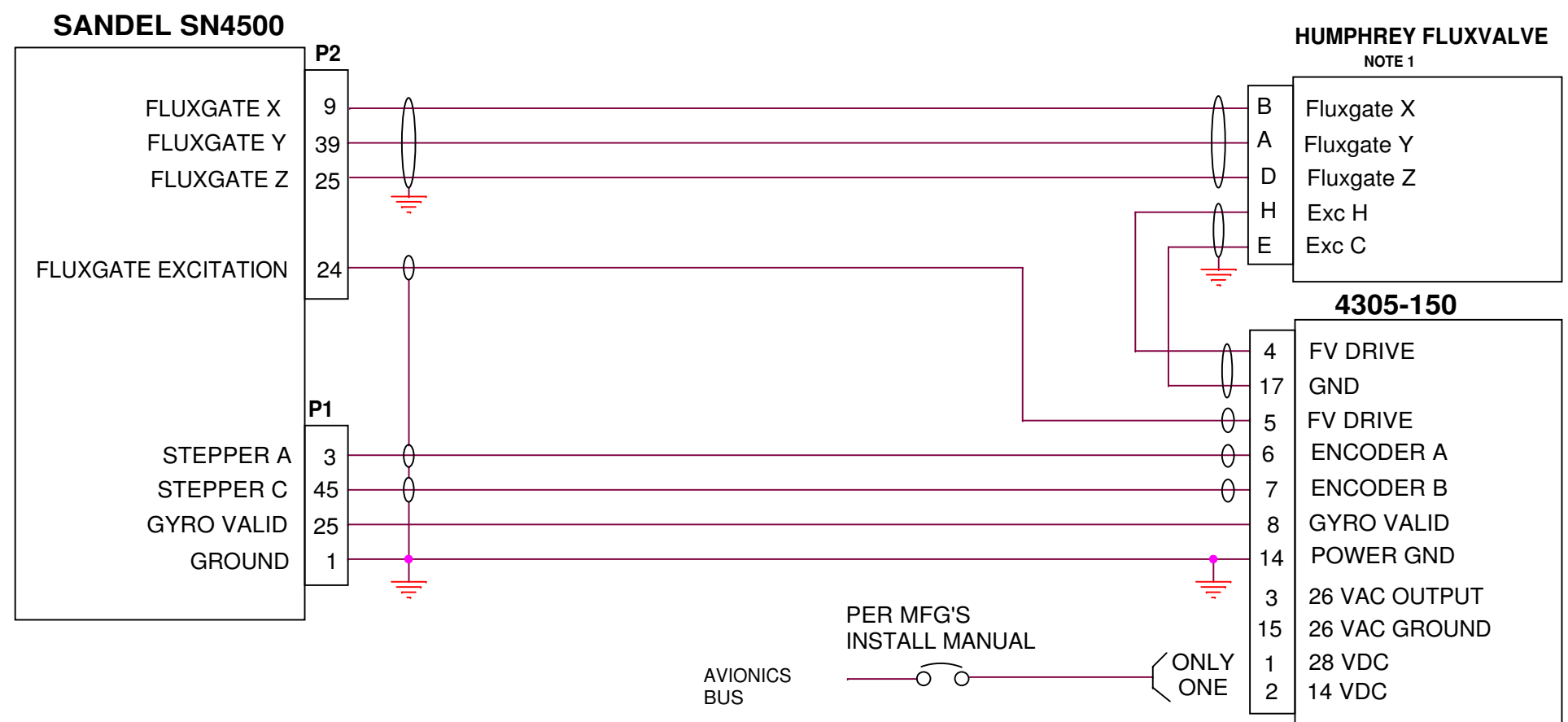

NOTES:

1. SELECT STEC 6446 FOR FLUXGATE TYPE

<b>SANDEL</b> ®		Vista, Ca.
Category SN4500 INSTALLATION DRAWING		
Title MID-CONTINENT 4305		
Size B	Document Number <b>82009-10</b>	Rev <b>A</b>
Create:	Mod:	Sheet 17

DATE	REV	COMMENTS
02-09-06	A	INITIAL RELEASE
10-28-06	B	FORMAT CHANGE. Ref A/R 867.

COMPUTER CONTROLLED DRAWING  
DO NOT REVISE MANUALLY

### XYZ COMPASS BOOTSTRAP OUTPUT

NOTE 1

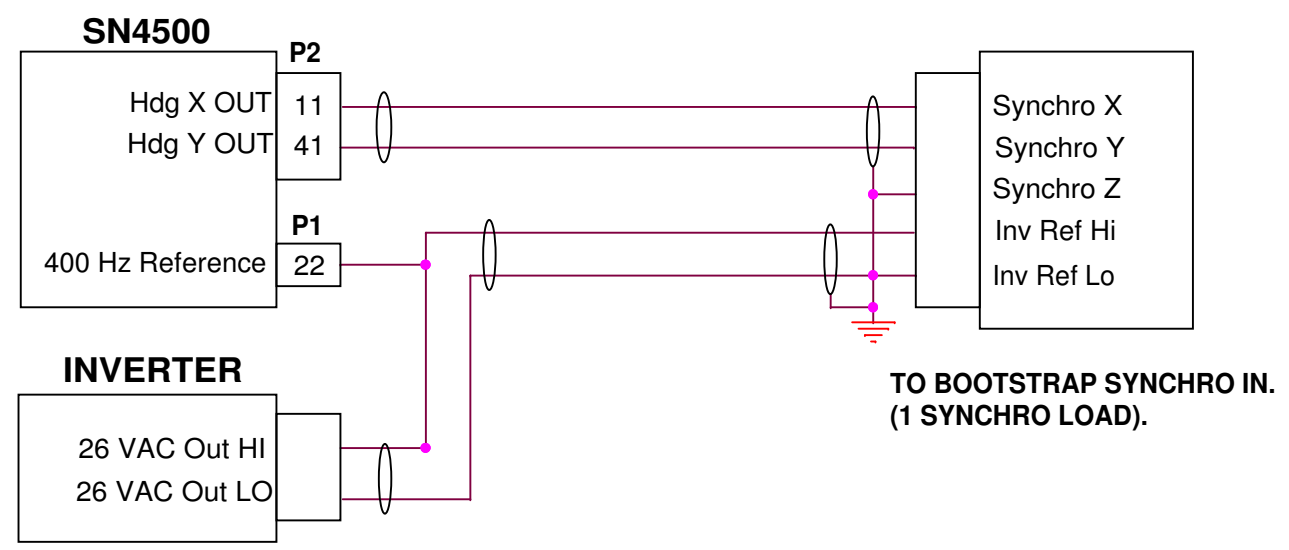

### 429 HDG OUTPUT

NOTE: 10Hz output rate

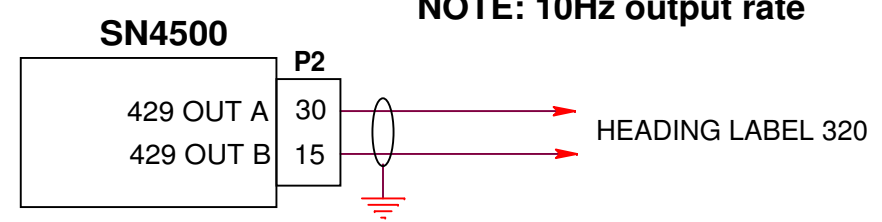

#### NOTES:

1. SELECT NORMAL OR REVERSE FOR BOOTSTRAP SETTING ON FCS EMULATION PAGE.

<b>SANDEL</b> ®		Vista, Ca.
Category SN4500 INSTALLATION DRAWING		
Title SN4500 COMPASS BOOTSTRAP		
Size B	Document Number <b>82009-10</b>	Rev <b>B</b>
Create:	Mod:	Sheet 18

DOTTED AREA REPRESENTS THE SN4500 INTERCONNECT.  
THE BALANCE OF THE DATA IS SHOWN FOR REFERENCE

DATE	REV	COMMENTS
02-09-06	A	INITIAL RELEASE
10-28-06	B	PIN CORRECTION GS + UP AND DOWN Ref A/R 867.
02/10/12	C	UPDATED P102 MINOR TYPO'S Ref A/R 12220

COMPUTER CONTROLLED DRAWING  
DO NOT REVISE MANUALLY

**KG102  
DIRECTIONAL  
GYRO**

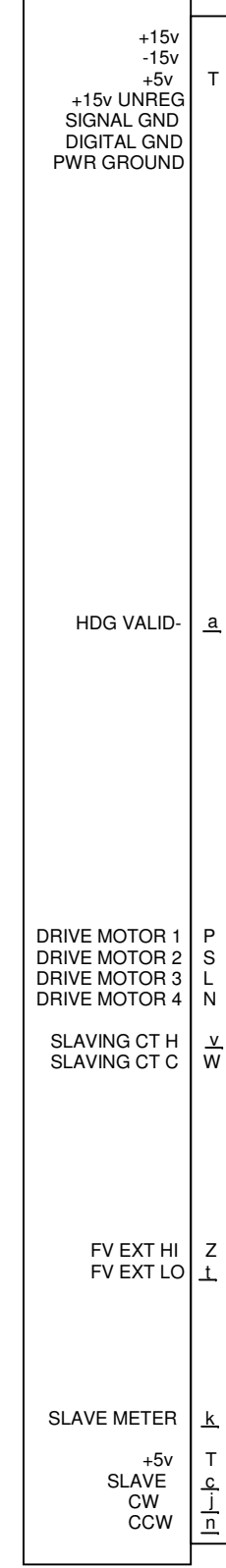

**KI-525 INDICATOR**

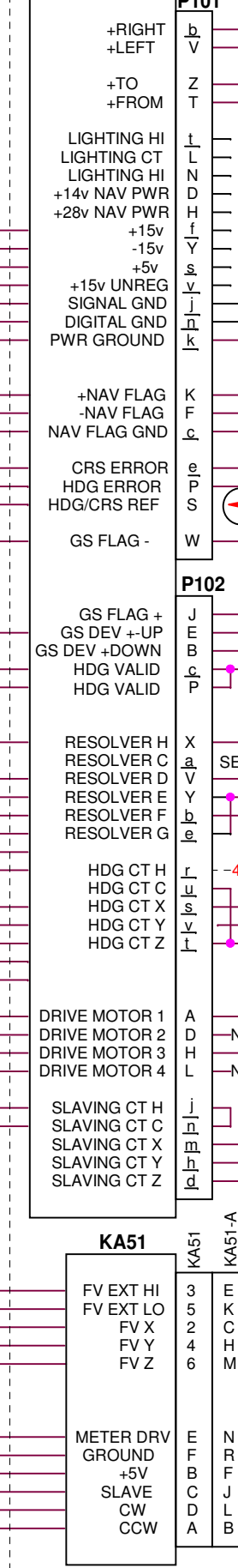

**SN4500**

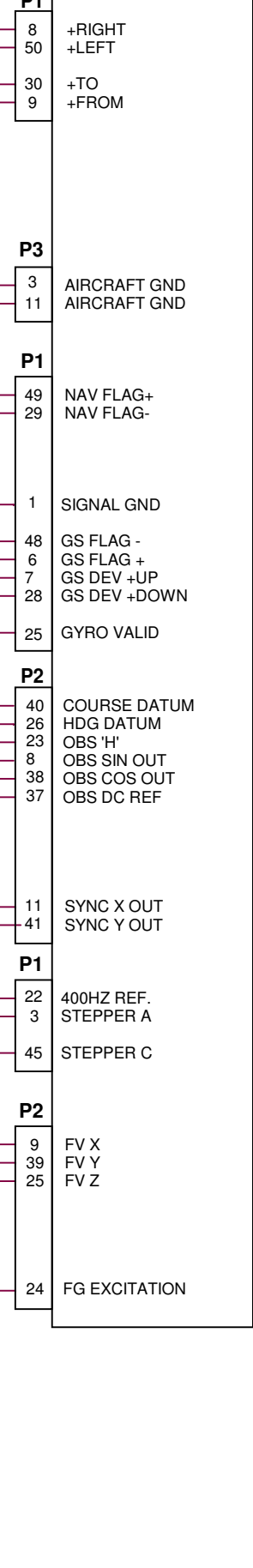

**NOTES:**

- 1: THE SYSTEM 400HZ INVERTER WILL NORMALLY BE CONNECTED TO THE HEADING SYNCHRO 'H' TERMINAL. THIS WIRE CAN BE USED TO DRIVE THE SN4500 REFERENCE INPUT. IN AN UNUSUAL CASE THE SYNCHRO MIGHT HAVE BEEN WIRED IN UPSIDE DOWN AND THE 400HZ REFERENCE MAY BE ON THE 'C' TERMINAL.
- 2: IF AN EXISTING CONVERTER IS INSTALLED SUCH AS A KA 52 OR KA 57, LEAVE UNIT INSTALLED AND SELECT KI525 ON FCS EMULATION PAGE.
3. SHOWN IS THE 30HZ RESOLVER INTERCONNECT. CHECK APPROPRIATE NAV RECEIVER SCHEMATICS BEFORE APPLYING POWER. TYING PINS E/G TOGETHER AS SHOWN ASSUMES THEM TO BE THE NAV RECEIVER VREF. THESE ARE NORMALLY TIED TOGETHER INSIDE THE NAV RECEIVER AND GO TO SIGNAL GROUND OR AN INTERNAL DC REFERENCE VOLTAGE. IF THESE DO NOT TIE INTERNALLY PLEASE CALL SANDEL FOR ASSISTANCE.
4. WHEN CONVERTING KCS-55 SYSTEM INSTALLATIONS THE KA-51 SLAVING ACCESSORY IS NOT USED. THE FLUXGATE EXCITATION SIGNAL CAN BE PICKED UP FROM THE EXISTING KA-51 CONNECTORS AS SHOWN.
5. PRIOR TO INSTALLING THE SN4500, ENSURE THAT THIS WIRE IS COMING FROM THE FLIGHT CONTROL SYSTEM GROUND AND THAT NO VOLTAGE IS PRESENT ON THIS PIN WITH POWER APPLIED TO ALL AVIONICS. IF VOLTAGE IS PRESENT, CONNECT SN4500 P1-1 TO FCS GROUND AT THE ROLL COMPUTER WITH A NEW WIRE. IF PRIMARY POWER IS APPLIED TO SN4500 P1-1 DAMAGE MAY OCCUR TO THE SN4500 RESULTING IN AN OPEN CIRCUIT AT P1-1. THIS CAN BE CHECKED WITH AN OHM METER.
6. RESISTOR MAY BE REQUIRED. SEE RESOLVER INTERCONNECT SHEET TO DETERMINE PROPER CONNECTION.

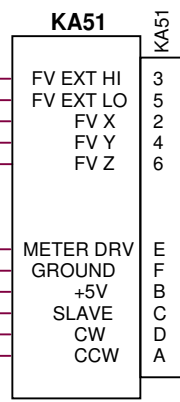
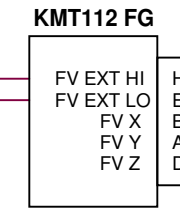

**SANDEL** Vista, Ca.

Category: SN4500 INSTALLATION DRAWING

Title: KCS-55 REMOVAL (REF)

Size B Document Number: **82009-10** Rev: **C**

Create: Mod: Sheet 19

DATE	REV	COMMENTS
6/9/98	A	INITIAL RELEASE
02-09-06	A	INITIAL RELEASE
10-28-06	B	CORRECTED NOTE REFERENCE CALLOUT Ref A/R 867.

COMPUTER CONTROLLED DRAWING  
DO NOT REVISE MANUALLY

**GPS/LORAN RECEIVER.  
KLN89-B SHOWN FOR  
REFERENCE.**

- FCS LOC ENGAGE P892 17
- VERT +FLAG P891 12
- VERT -FLAG 13
- VERT +UP P892 13
- VERT +DOWN 14
- LAT +FLAG P891 10
- LAT -FLAG 11
- LAT +LEFT P892 11
- LAT +RIGHT 12
- +TO 32
- +FROM 33
- KLN89-B SHOWN  
SEE NOTE 3**
- OBS OUT 34
- OBS RETURN 37
- OBS SIN 35
- OBS COS 36
- GPS DISPLAYED 31
- MSG- ANNUN P891 16
- ARM- ANNUN 18
- APPR- ANNUN 17
- WPT- ANNUN 15
- RS232-TX 2
- APPR ARM IN P892 8

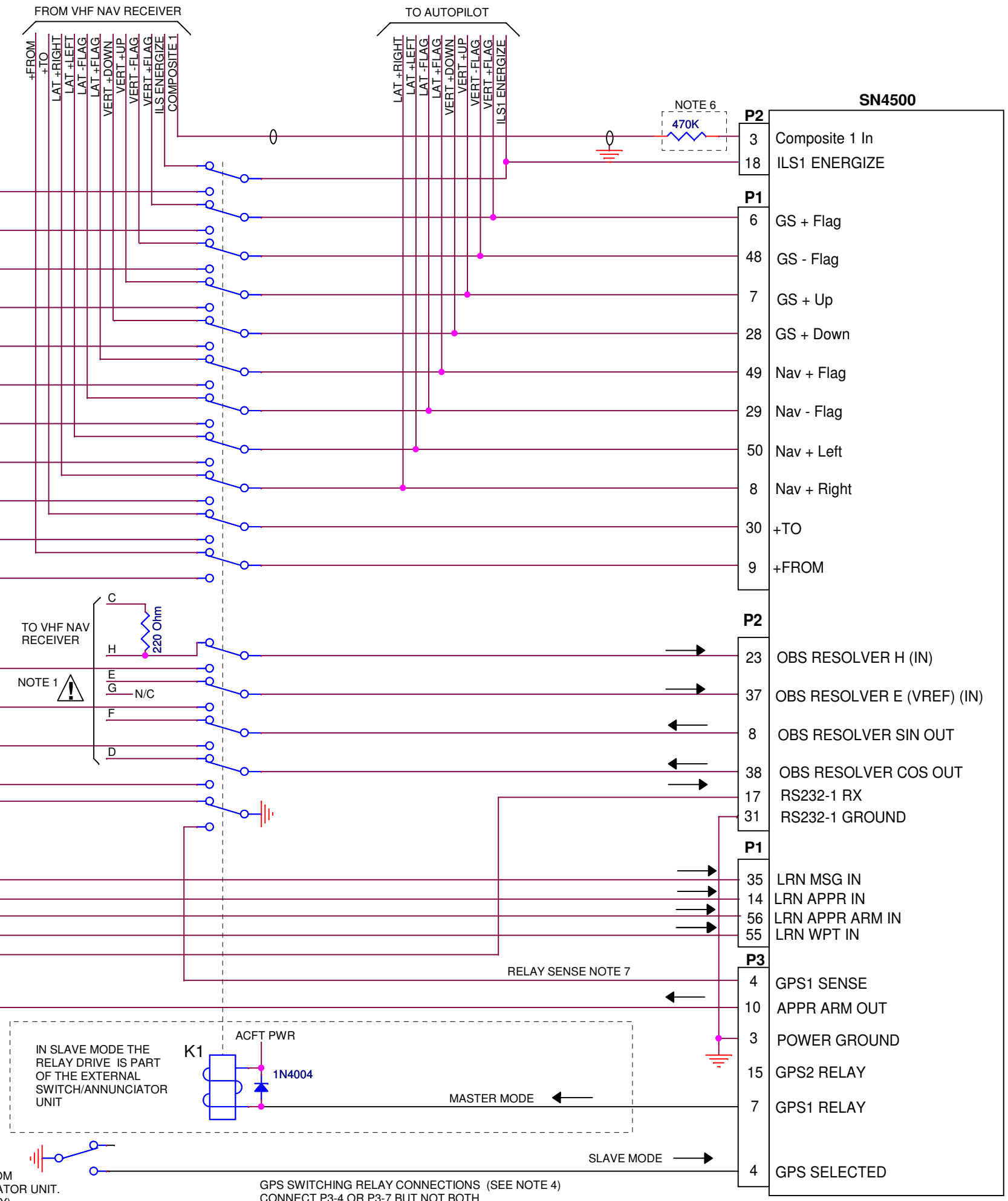

**NAV-1 AND RS-232 GPS INTERCONNECT  
KLN89-B SHOWN FOR REFERENCE**

KX165 / KNS80 / KNS81 SWITCHING, SEE NOTE 2

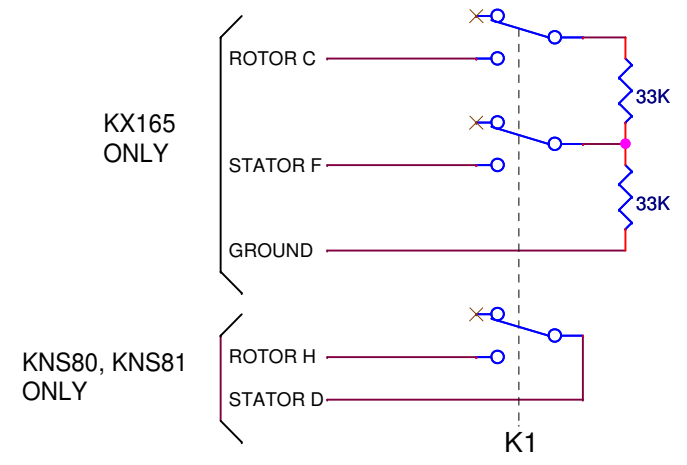

NOTES:

- CONNECT OBS "H" FROM RECEIVER "H" or "C" WHICHEVER IS THE ACTIVE OUTPUT. CHECK APPROPRIATE NAV RECEIVER SCHEMATICS. CONNECT "SIN OUT" and "COS OUT" TO THE ACTIVE RETURN PINS, USUALLY D/F. CONNECT "OBS VREF" TO EITHER STATOR RETURN PIN (REF OR GROUND) USUALLY E or G. THE LOAD RESISTOR SIMULATES A SYNCHRO.
- THESE CONNECTIONS FOR KX165 OR KNX80/81 PREVENT THE RECEIVER FROM FLAGGING THE NAV SIGNAL WHEN THE RESOLVER IS BEING USED BY THE GPS. CONSULT THE APPROPRIATE KING DOCUMENTATION FOR FURTHER INFORMATION.
- SEE ARINC-429 INSTALLATION PAGE WHICH DOES NOT REQUIRE THE RESOLVER SWITCHING RELAY (WHERE APPLICABLE).
- THE PREFERRED INSTALLATION IS THE SN4500 P3-7 CONTROLLING AN EXTERNAL SWITCHING RELAY. IF AN EXISTING SWITCH CONTROL BOX IS INSTALLED AND IT IS DESIRED TO LEAVE IT OPERATIONAL, USE P3-4 TO SENSE GPS MODE AND SELECT SLAVE FOR THE MODE SETTING ON THE OBS/RELAY/CDI MAINTENANCE PAGE.
  - 1 MASTER: SN4500 CONTROLS THE NAV/GPS SWITCHING (PREFERRED)
  - 2 SLAVE: EXTERNAL NAV/GPS SWITCH CONTROLS THE SN4500
- CHECK MANUFACTURERS DOCUMENTATION FOR ANY ADDITIONAL INSTALLATION SPECIFIC RELAY POLES WHICH MAY ALSO BE NEEDED.
- FOR 3V COMPOSITE NAV SOURCES INSERT A 470K SERIES RESISTOR LOCATED AT THE SN4500 CONNECTOR. NOT REQUIRED FOR .5V SOURCE.
- ONLY USED WHEN SN4500 IS IN MASTER MODE. SELECT GPS1 FOR SENSE ON OBS/RELAY/CDI MAINTENANCE PAGE.

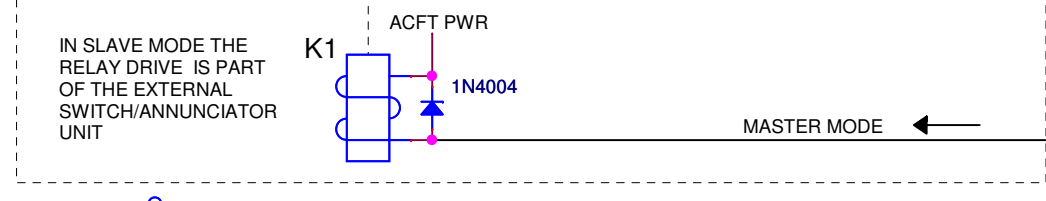

GPS ENABLED FROM SWITCH/ANNUNCIATOR UNIT. (SLAVE MODE ONLY)

GPS SWITCHING RELAY CONNECTIONS (SEE NOTE 4)  
CONNECT P3-4 OR P3-7 BUT NOT BOTH.

**SANDEL** Vista, Ca.

Category: SN4500 INSTALLATION DRAWING

Title: NAV-1 RS-232 GPS (EXT RELAY)

Size B Document Number: **82009-10** Rev **B**

Create: Mod: Sheet 20

DATE	REV	COMMENTS
02-09-06	A	INITIAL RELEASE
10-28-06	B	REMOVED OBS CONNECTIONS AND NOTES. Ref A/R 867.
03-25-10	C	ADDED NOTE 6, Ref A/R 1114.

COMPUTER CONTROLLED DRAWING  
DO NOT REVISE MANUALLY

# THIS DIAGRAM SHOWS USE OF INTERNAL NAV CONVERTER AND DEVIATION RELAY OF SN4500

FOR AUTOPILOT INTERCONNT SEE PAGE "FCS DEVIATION (INTERNAL RELAY)"

GPS/LORAN RECEIVER.  
KLN89-B SHOWN FOR  
REFERENCE.

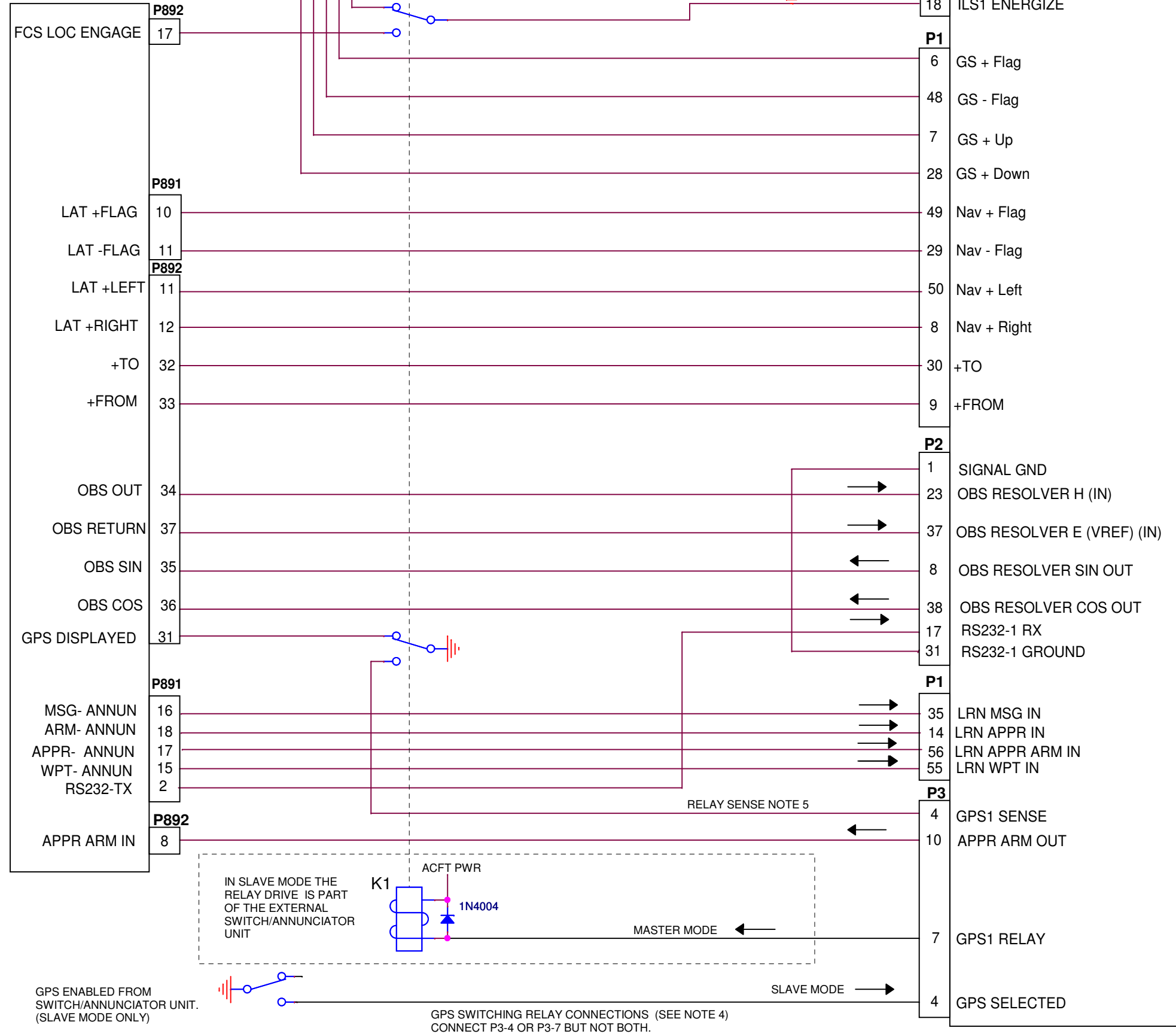

NOTES:

- SEE ARINC-429 INSTALLATION PAGE WHICH DOES NOT REQUIRE THE RESOLVER SWITCHING RELAY (WHERE APPLICABLE).
- FOR 3V COMPOSITE NAV SOURCES INSERT A 470K SERIES RESISTOR LOCATED AT THE SN4500 CONNECTOR. NOT REQUIRED FOR .5V SOURCE.
- THE PREFERRED INSTALLATION IS THE SN4500 P3-7 CONTROLLING AN EXTERNAL SWITCHING RELAY. IF AN EXISTING SWITCH CONTROL BOX IS INSTALLED AND IT IS DESIRED TO LEAVE IT OPERATIONAL, USE P3-4 TO SENSE GPS MODE AND SELECT SLAVE FOR THE MODE SETTING ON THE OBS/RELAY/CDI MAINTENANCE PAGE.
  - (1) MASTER: SN4500 CONTROLS THE NAV/GPS SWITCHING (PREFERRED)
  - (2) SLAVE: EXTERNAL NAV/GPS SWITCH CONTROLS THE SN4500
- CHECK MANUFACTURERS DOCUMENTATION FOR ANY ADDITIONAL INSTALLATION SPECIFIC RELAY POLES WHICH MAY ALSO BE NEEDED.
- ONLY USED WHEN SN4500 IS IN MASTER MODE. SELECT GPS1 FOR SENSE ON OBS/RELAY/CDI MAINTENANCE PAGE.
- WHEN USING THE COMPOSITE INPUT FOR Iloc DEVIATION, THE CALIBRATION PROCEDURE FOUND IN SECTION 7.1.5 MUST BE FOLLOWED FOR EACH SPECIFIC LOC INPUT.

<b>SANDEL</b> ® Vista, Ca.	
Category	SN4500 INSTALLATION DRAWING
Title	NAV-1 RS-232 GPS (INT RELAY)
Size B	Document Number <b>82009-10</b>
Rev	<b>C</b>
Create:	Mod: Sheet 21

**GPS/LORAN RECEIVER.  
KLN-90B SHOWN FOR  
REFERENCE**

**NAV-1 AND ARINC 429 GPS INTERCONNECT.  
KLN90-B SHOWN FOR REFERENCE**

COMPUTER CONTROLLED DRAWING  
DO NOT REVISE MANUALLY

DATE	REV	COMMENTS
02-09-06	A	INITIAL RELEASE
10-28-06	B	UPDATE NOTES. Ref A/R 867.
03-25-10	C	ADDED NOTE 12, Ref A/R 1114.

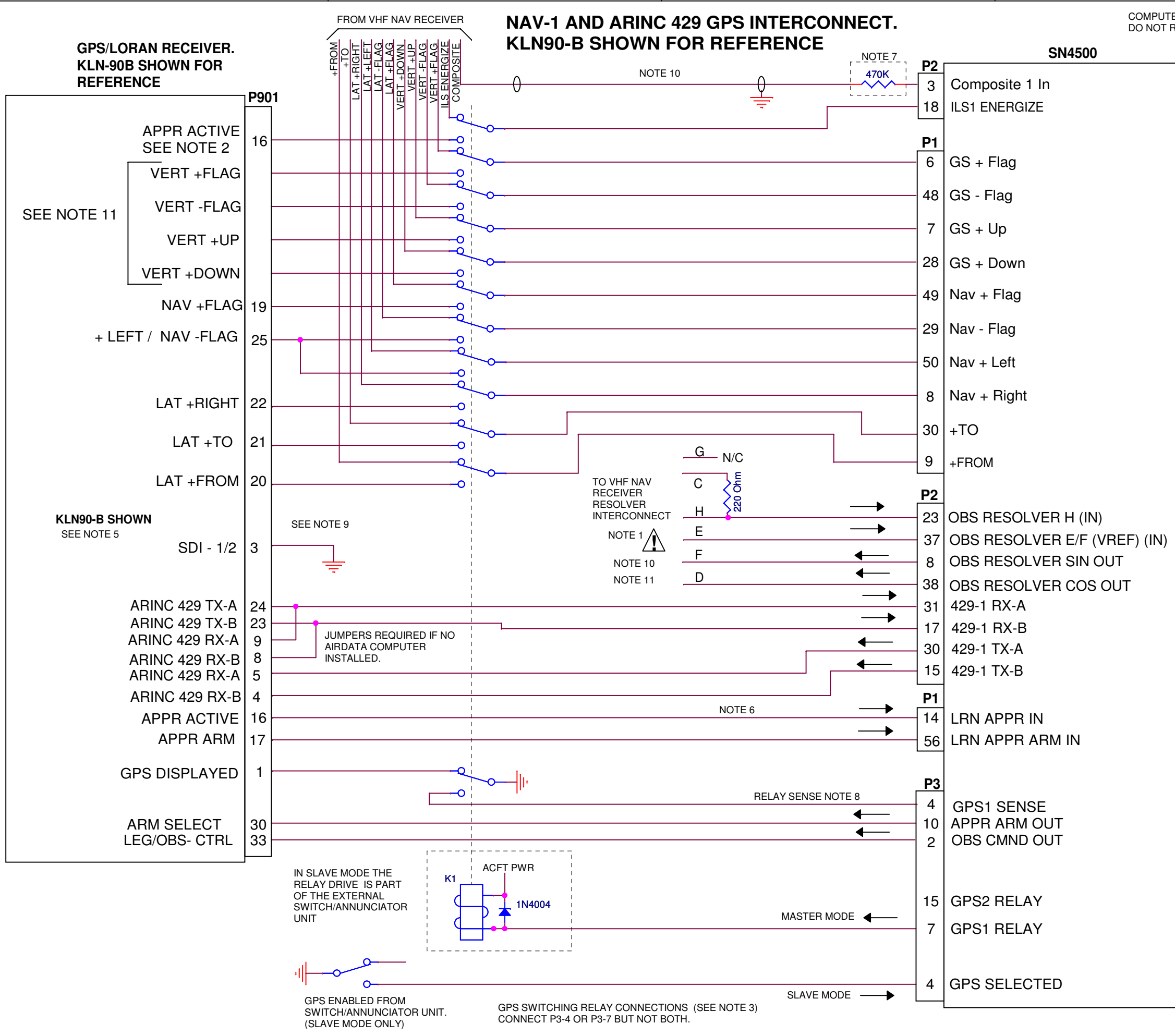

**NOTES:**

- WHEN USING 429 LEVEL 100 CORRECTED COURSE OBS SIGNAL CONNECTIONS ARE NOT NEEDED. SEE NOTE 11. CONNECT OBS "H" FROM RECEIVER "H" or "C" WHICHEVER IS THE ACTIVE OUTPUT. CHECK APPROPRIATE NAV RECEIVER SCHEMATICS. CONNECT "SIN OUT" and "COS OUT" TO THE ACTIVE RETURN PINS, USUALLY D/F. CONNECT "OBS VREF" TO EITHER STATOR RETURN PIN (REF OR GROUND) USUALLY E or G. THE LOAD RESISTOR SIMULATES A SYNCHRO.
- THE APPROACH ACTIVE OUTPUT FROM THE GPS TO THE AUTOPILOT MAY HAVE TO BE AN ADDITIONAL RELAY. SEE THE MANUFACTURERS INSTALLATION DIAGRAMS.
- THE PREFERRED INSTALLATION IS THE SN4500 P3-7 CONTROLLING AN EXTERNAL SWITCHING RELAY. IF AN EXISTING SWITCH CONTROL BOX IS INSTALLED AND IT IS DESIRED TO LEAVE IT OPERATIONAL, USE P3-4 TO SENSE GPS MODE AND SELECT SLAVE FOR THE MODE SETTING ON THE OBS/RELAY/CDI MAINTENANCE PAGE.
  - MASTER: SN4500 CONTROLS THE NAV/GPS SWITCHING (PREFERRED)
  - SLAVE: EXTERNAL NAV/GPS SWITCH CONTROLS THE SN4500
- CHECK MANUFACTURERS DOCUMENTATION FOR ANY ADDITIONAL INSTALLATION SPECIFIC RELAY POLES WHICH MAY ALSO BE NEEDED.
- KLN-90B PINOUTS SHOWN. CERTAIN CONNECTIONS SUCH AS GPS\_DISPLAYED AND OBS/LEG ARE SPECIFIC TO KLN-90B.
- MSG AND WPT ANNUNCIATORS ARE COMMUNICATED ON THE ARINC 429 SERIAL CHANNEL.
- FOR 3V COMPOSITE NAV SOURCES INSERT A 470K SERIES RESISTOR LOCATED AT THE SN4500 CONNECTOR. NOT REQUIRED FOR .5V SOURCE.
- ONLY USED WHEN SN4500 IS IN MASTER MODE. SELECT GPS1 FOR SENSE ON OBS/RELAY/CDI MAINTENANCE PAGE.
- IF KLN-90B IS USED FOR GPS1, LEAVE SDI-1/2 PIN 3 OF KLN-90B NOT CONNECTED. IF KLN-90B IS WIRED FOR GPS2, THEN CONNECT SDI-1/2 PIN 3 OF KLN-90B TO GROUND.
- IF USING COMPOSITE SIGNAL IN P2-3 THEN NAV SIGNALS FLAG, DEVIATION AND TO-FROM ARE NOT REQUIRED TO BE CONNECTED TO P1 AS WELL AS P2 RESOLVER CONNECTIONS. GLIDESLOPE FLAG AND GLIDESLOPE DEVIATIONS SIGNALS ARE STILL REQUIRED. WHEN USING ANALOG INPUTS FOR NAV THEN COMPOSITE IS NOT REQUIRED. WHEN USING ANALOG INPUTS WITHOUT COMPOSITE SIGNAL NAV BEARING POINTERS ARE NOT SUPPORTED.
- NOT USED ON KLN-90B WHEN USING ARINC 429 LABEL 100.
- WHEN USING THE COMPOSITE INPUT FOR loc DEVIATION, THE CALIBRATION PROCEDURE FOUND IN SECTION 7.1.5 MUST BE FOLLOWED FOR EACH SPECIFIC LOC INPUT.

**SANDEL** Vista, Ca.

Category: SN4500 INSTALLATION DRAWING

Title: NAV-1 / ARINC-429 GPS (EXT RELAY)

Size B Document Number: **82009-10** Rev **C**

Create: Mod: Sheet 22

GPS/LORAN RECEIVER.  
KLN-90B SHOWN FOR  
REFERENCE

THIS DIAGRAM SHOWS USE OF INTERNAL NAV CONVERTER AND  
DEVIATION RELAY OF SN4500

DATE	REV	COMMENTS
02-09-06	A	INITIAL RELEASE
10-28-06	B	UPDATE NOTES. Ref A/R 867.
03-25-10	C	ADDED NOTE 9, Ref A/R 1114.

COMPUTER CONTROLLED DRAWING  
DO NOT REVISE MANUALLY

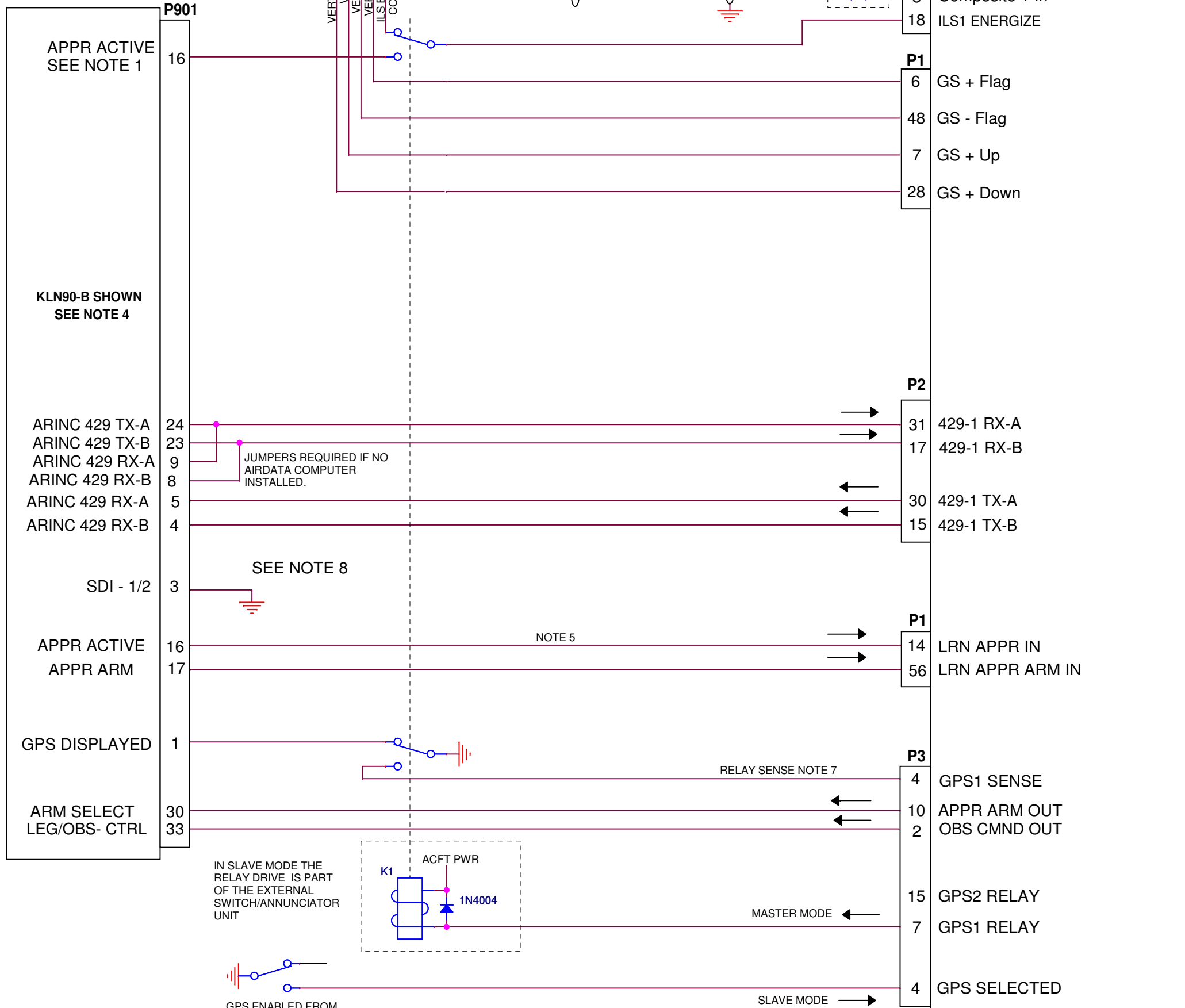

NAV-1 AND ARINC 429 GPS INTERCONNECT.  
KLN90-B SHOWN FOR REFERENCE

NOTES:

1. THE APPROACH ACTIVE OUTPUT FROM THE GPS TO THE AUTOPILOT MAY HAVE TO BE AN ADDITIONAL RELAY. SEE THE MANUFACTURERS INSTALLATION DIAGRAMS.
2. THE PREFERRED INSTALLATION IS THE SN4500 P3-7 CONTROLLING AN EXTERNAL SWITCHING RELAY. IF AN EXISTING SWITCH CONTROL BOX IS INSTALLED AND IT IS DESIRED TO LEAVE IT OPERATIONAL, USE P3-4 TO SENSE GPS MODE AND SELECT SLAVE FOR THE MODE SETTING ON THE OBS/RELAY/CDI MAINTENANCE PAGE.
  - (1) MASTER: SN4500 CONTROLS THE NAV/GPS SWITCHING (PREFERRED)
  - (2) SLAVE: EXTERNAL NAV/GPS SWITCH CONTROLS THE SN4500
3. CHECK MANUFACTURERS DOCUMENTATION FOR ANY ADDITIONAL INSTALLATION SPECIFIC RELAY POLES WHICH MAY ALSO BE NEEDED.
4. KLN-90B PINOUTS SHOWN. CERTAIN CONNECTIONS SUCH AS GPS\_DISPLAYED AND OBS/LEG ARE SPECIFIC TO KLN-90B.
5. MSG AND WPT ANNUNCIATORS ARE COMMUNICATED ON THE ARINC 429 SERIAL CHANNEL.
6. FOR 3V COMPOSITE NAV SOURCES INSERT A 470K SERIES RESISTOR LOCATED AT THE SN4500 CONNECTOR. NOT REQUIRED FOR .5V SOURCE.
7. ONLY USED WHEN SN4500 IS IN MASTER MODE. SELECT GPS1 FOR SENSE ON OBS/RELAY/CDI MAINTENANCE PAGE.
8. IF KLN-90B IS USED FOR GPS1, LEAVE SDI-1/2 PIN 3 OPEN. IF THE KLN-90B IS WIRED FOR GPS2 THEN GROUND P901-3 AT THE GPS.
9. WHEN USING THE COMPOSITE INPUT FOR LOC DEVIATION, THE CALIBRATION PROCEDURE FOUND IN SECTION 7.1.5 MUST BE FOLLOWED FOR EACH SPECIFIC LOC INPUT.

IN SLAVE MODE THE  
RELAY DRIVE IS PART  
OF THE EXTERNAL  
SWITCH/ANNUNCIATOR  
UNIT

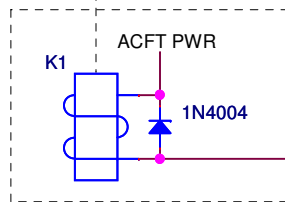
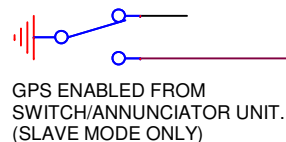

GPS SWITCHING RELAY CONNECTIONS (SEE NOTE 3)  
CONNECT P3-4 OR P3-7 BUT NOT BOTH.

**SANDEL**® Vista, Ca.  
Category SN4500 INSTALLATION DRAWING  
Title NAV-1 / ARINC-429 GPS (INT RELAY)  
Size B Document Number **82009-10** Rev **C**  
Create: Mod: Sheet 23



DATE	REV	COMMENTS
02-09-06	A	INITIAL RELEASE
10-28-06	B	ADDED SUPER FLAG OPTION. Ref A/R 867.
03-25-10	C	ADDED NOTE 3, Ref A/R 1114.
11/13/13	D	TITLE UPDATED TO INCLUDE SUPERFLAGS
03/07/22	E	NOTE 1: REPLACED REFERENCE TO SN3500 WITH SN4500

COMPUTER CONTROLLED DRAWING  
DO NOT REVISE MANUALLY

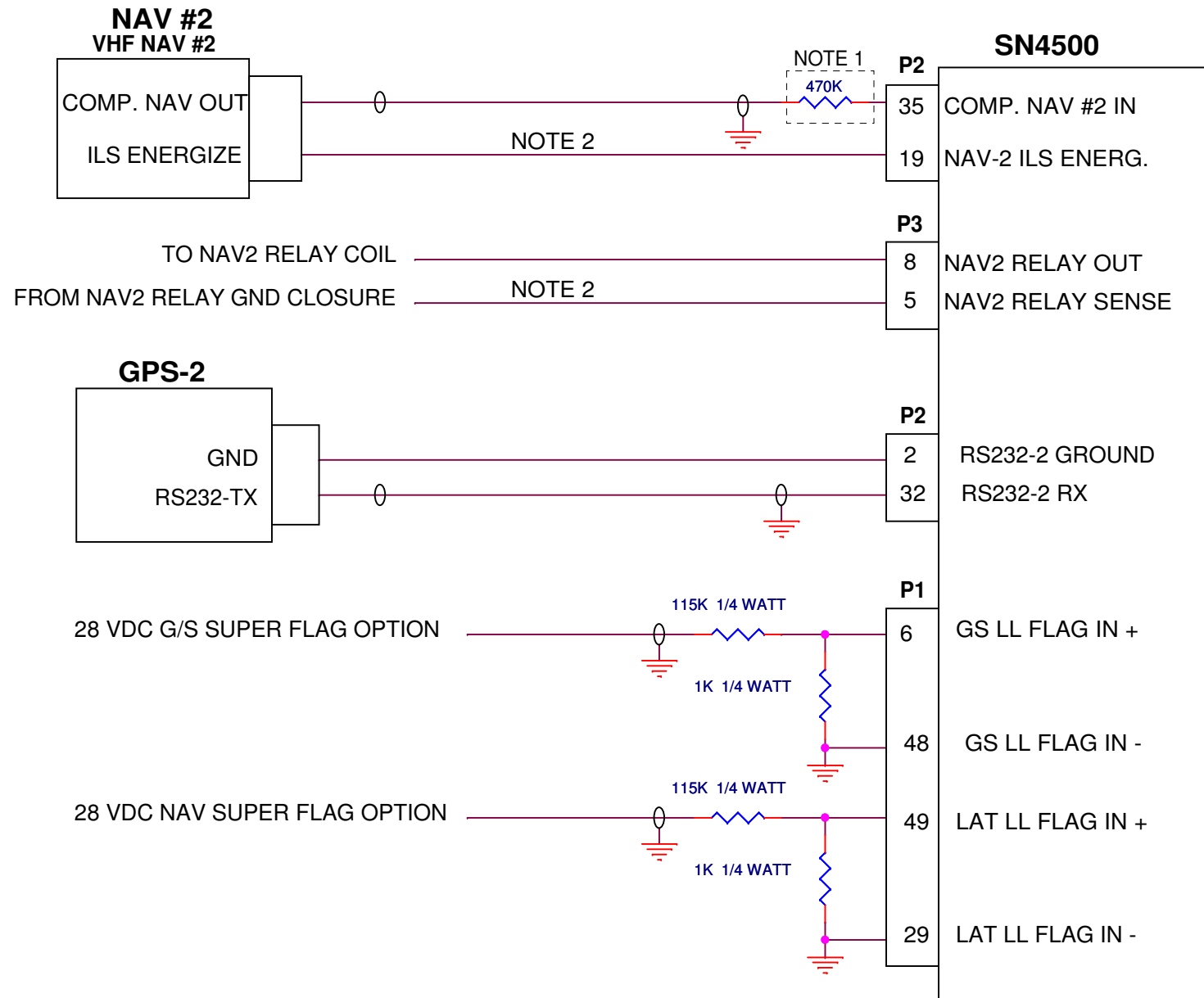

**NOTES:**

- FOR 3V COMPOSITE NAV SOURCES INSERT A 470K SERIES RESISTOR LOCATED AT THE SN4500 CONNECTOR. NOT REQUIRED FOR 0.5V SOURCE.
- ILS ENERGIZE AND RELAY SWITCHING OUTPUT ARE ONLY REQUIRED IF NAV-2 IS TO BE USED AS A SECOND PRIMARY VHF NAV RECEIVER. IN THIS CONFIGURATION A 2ND SWITCHING RELAY IS ADDED TO SWITCH THE DBAR AND FLAG INPUTS FROM THE 2ND RECEIVER IN THE SAME MANNER AS THE GPS SWITCHING RELAY SHOWN FOR NAV-1 ON THE PREVIOUS PAGE.
- WHEN USING THE COMPOSITE INPUT FOR LOC DEVIATION, THE CALIBRATION PROCEDURE FOUND IN SECTION 7.1.5 MUST BE FOLLOWED FOR EACH SPECIFIC LOC INPUT.

<b>SANDEL</b> ®		Vista, Ca.
Category	SN4500 INSTALLATION DRAWING	
Title	NAV-2, GPS-2 (RS232), SUPERFLAGS	
Size B	Document Number	Rev
	<b>82009-10</b>	<b>E</b>
Create:	Mod:	Sheet 24

DATE	REV	COMMENTS
6/9/98	A	INITIAL RELEASE
10-28-06	A	INITIAL RELEASE

COMPUTER CONTROLLED DRAWING  
DO NOT REVISE MANUALLY

**KLN-94 GPS RECEIVER WITH ANALOG NAV**

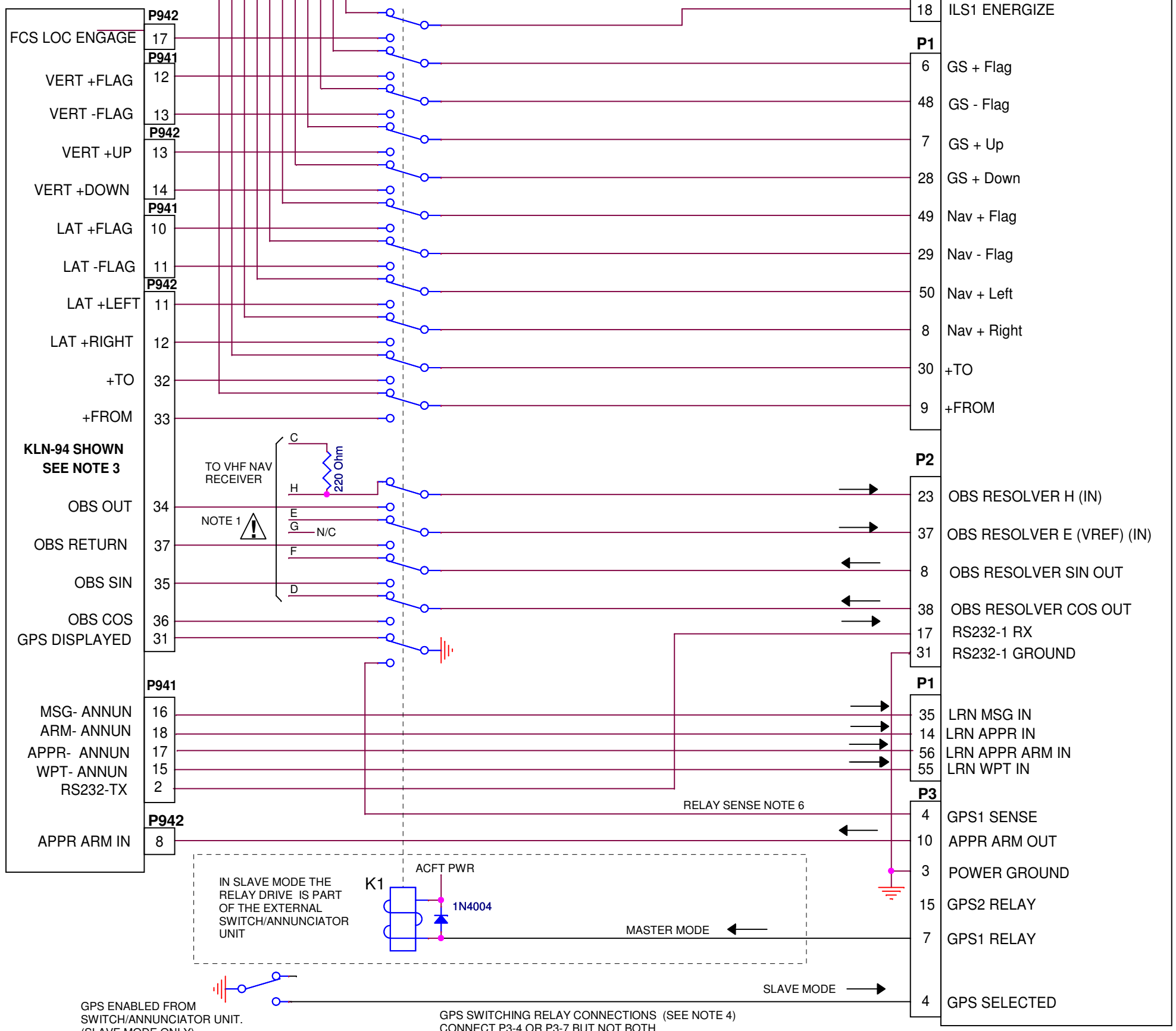

**NAV-1 AND RS-232 GPS INTERCONNECT**  
KLN-94 SHOWN FOR REFERENCE  
KX165 / KNS80 / KNS81 SWITCHING, SEE NOTE 2

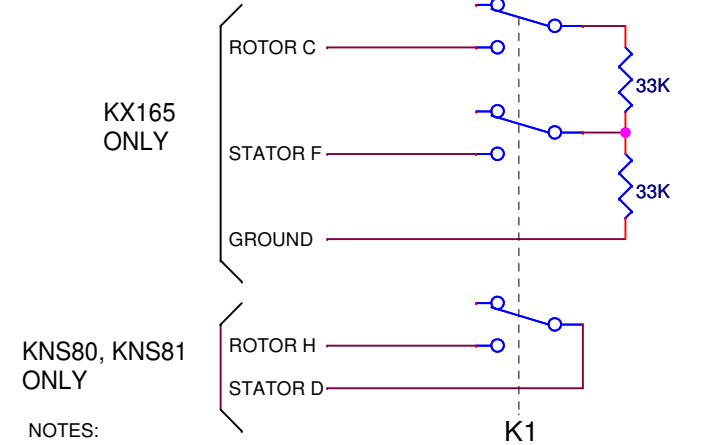

NOTES:

- CONNECT OBS "H" FROM RECEIVER "H" or "C" WHICHEVER IS THE ACTIVE OUTPUT. CHECK APPROPRIATE NAV RECEIVER SCHEMATICS. CONNECT "SIN OUT" and "COS OUT" TO THE ACTIVE RETURN PINS, USUALLY D/F. CONNECT "OBS VREF" TO EITHER STATOR RETURN PIN (REF OR GROUND) USUALLY E or G. THE LOAD RESISTOR SIMULATES A SYNCHRO.
- THESE CONNECTIONS FOR KX165 OR KNS80/81 PREVENT THE RECEIVER FROM FLAGGING THE NAV SIGNAL WHEN THE RESOLVER IS BEING USED BY THE GPS. CONSULT THE APPROPRIATE KING DOCUMENTATION FOR FURTHER INFORMATION.
- KLN-94 MUST BE SET FOR "EXTENDED RS-232" ON MAINTENANCE PAGE 7 OF THE KLN-94.
- THE PREFERRED INSTALLATION IS THE SN4500 P3-7 CONTROLLING AN EXTERNAL SWITCHING RELAY. IF AN EXISTING SWITCH CONTROL BOX IS INSTALLED AND IT IS DESIRED TO LEAVE IT OPERATIONAL, USE P3-4 TO SENSE GPS MODE AND SELECT SLAVE FOR THE MODE SETTING ON THE OBS/RELAY/CDI MAINTENANCE PAGE.
  - (1) MASTER: SN4500 CONTROLS THE NAV/GPS SWITCHING (PREFERRED)
  - (2) SLAVE: EXTERNAL NAV/GPS SWITCH CONTROLS THE SN4500
- CHECK MANUFACTURERS DOCUMENTATION FOR ANY ADDITIONAL INSTALLATION SPECIFIC RELAY POLES WHICH MAY ALSO BE NEEDED.
- ONLY USED WHEN SN4500 IS CONFIGURED AS MASTER. SELECT GPS1 FOR SENSE ON OBS/RELAY/CDI MAINTENANCE PAGE.
- NAV BEARING POINTER IS NOT SUPPORTED IN THIS CONFIGURATION. FOR NAV BEARING POINTER CONNECT COMPOSITE NAV SIGNAL TO SN4500 IF AVAILABLE.

**SANDEL®** Vista, Ca.

Category: **SN4500 INSTALLATION DRAWING**

Title: **KLN-94 INTERFACE WITH ANALOG NAV**

Size B | Document Number: **82009-10** | Rev **A**

Create: | Mod: | Sheet 25

# GNS480 GPS RECEIVER

# SN4500 EHSI

COMPUTER CONTROLLED DRAWING  
DO NOT REVISE MANUALLY

DATE	REV	COMMENTS
6/9/98	A	
02-09-06	A	INITIAL RELEASE
10-28-06	B	CORRECTED NOTES. Ref A/R 867.

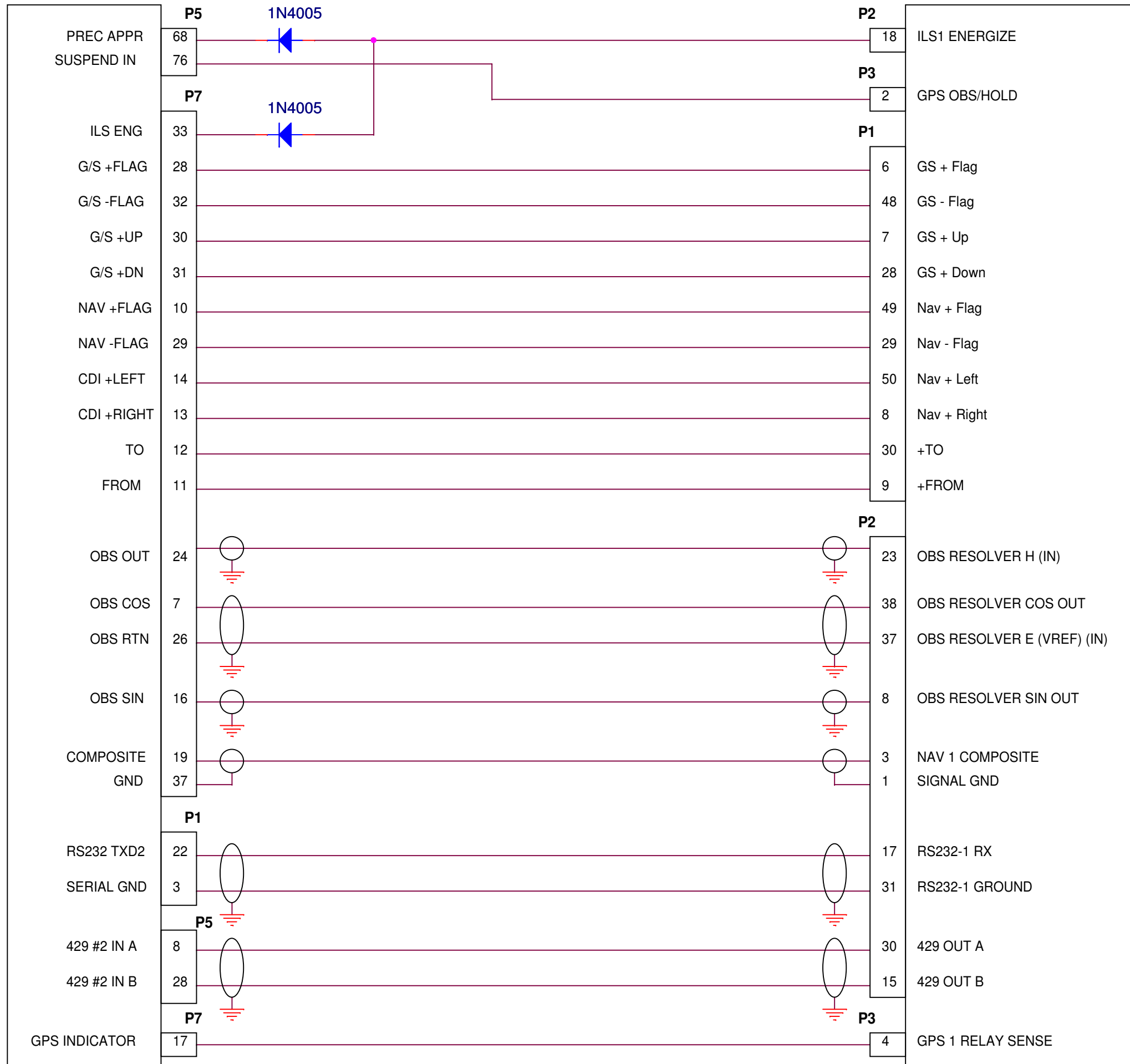

## NOTES:

- GNS 480 SERIAL PORT SETUP ITEMS:  
SERIAL SETUP (RX / TX)  
SERIAL PORT 2: XXX / MAPCOM (9600)  
ARINC 429 SETUP:  
CH2\_IN: AHRS LOW
- SN4500 SETUP ITEMS:  
  
GPS SELECT: IIMORROW GX (RS-232-ENH)  
ANNUN = SERIAL  
LAT DEV = ANALOG  
VERT DEV = ANALOG  
VERT ENA = ACTIVE L  
OBS CAL = 0.0  
  
NAV SELECT:  
NAV = COMP  
CAL = 17.0  
ENRGZ = ACTIVE L  
LOC DV = ANALOG/COMP (SEE NOTE 5)  
GS DV = ANALOG  
OBS = 0.0  
  
RELAY:  
OBS ROT = REVERSED  
MODE = SLAVE  
SENSE = GPS1
- THE INSTALLER IS RESPONSIBLE TO INCLUDE IN THE AFMS THE FOLLOWING TEXT:  
" DME ARCS AND HOLDING PATTERNS WILL NOT BE DISPLAYED ON THE SN4500 EHSI."
- IN THIS CONFIGURATION A RELAY SENSE ERROR WILL BE DISPLAYED ON THE SN4500 WHEN THE GNS480 IS SET TO NAV AND THE SN4500 IS SELECTING GPS1.
- SELECT "COMP" ON NAV1 MAINTENANCE PAGE IN THE SN4500 FOR BOTH "NAV" AND "LOC" DEVIATION AND THEN YOU MUST ENTER GNS480 MAINTENANCE MODE AND CALIBRATE THE "OBS". AFTER CALLIBRATION IS COMPLETE SET THE "LOC" DEVIATION TO "ANALOG" IN ORDER FOR THE GNS480 SELF TEST TO WORK PROPERLY.

<b>SANDEL</b> ® Vista, Ca.	
Category	SN4500 INSTALLATION DRAWING
Title	<b>SINGLE SN4500 GNS480</b>
Size B	Document Number <b>82009-10</b> Rev <b>B</b>
Create:	Mod: Sheet 26

DATE	REV	COMMENTS
02-09-06	A	INITIAL RELEASE
10-28-06	B	CORRECTED NOTES. Ref A/R 867.
11-11-13	C	A/R 1378 Garmin GTN6XX/7XX added. Notes updated for GTN6XX/7XX. Drawing title updated for 6XX/7XX.
03-07-22	D	Corrected Note 2 VERT ENA setting to VERT DV FLAG. Corrected pin numbers on GTN 6XX/7XX P1001 connector. Added shield grounds on both sides.

COMPUTER CONTROLLED DRAWING  
DO NOT REVISE MANUALLY

Connection to Desired Pins for unit 1 or 2

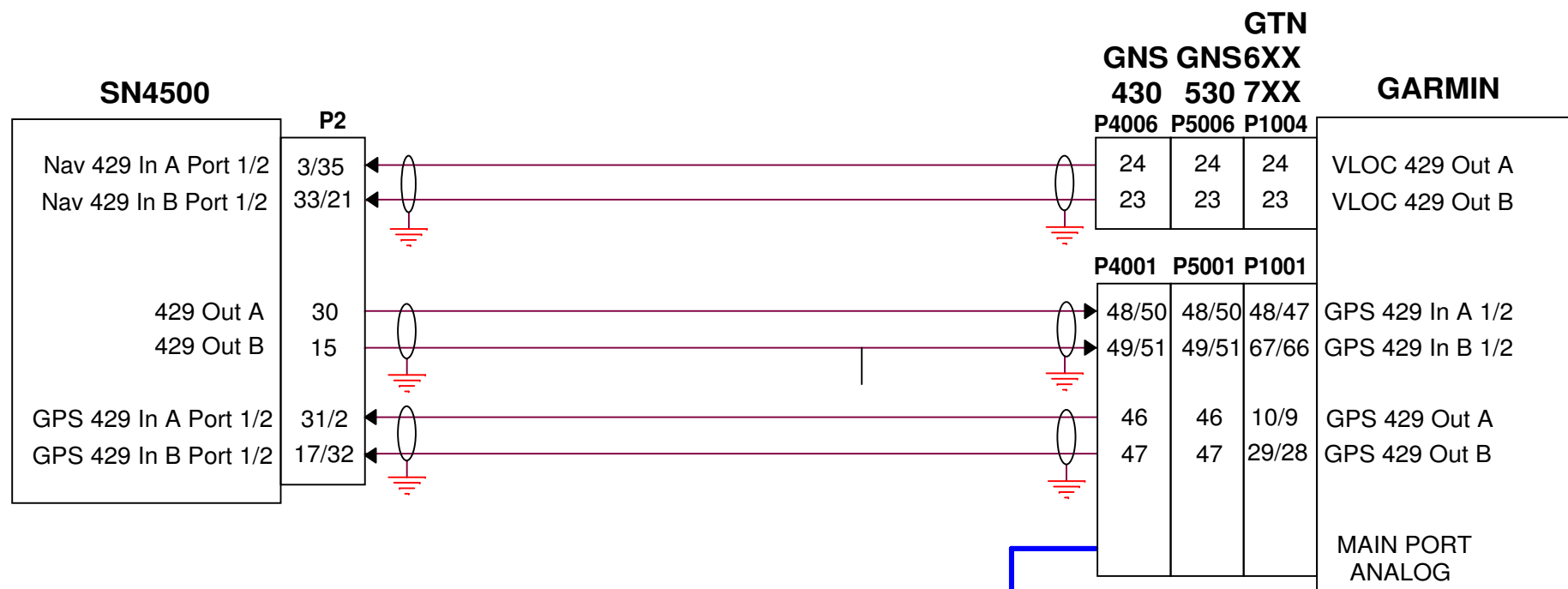

Connection to One Port ONLY!  
(48/49) OR (50/51)  
(48/67) OR (67/66) for GTN 6XX/7XX

For GTN6XX/7XX - Connection to One Port Only!  
(10/29) or (9/28)

TO AUTOPILOT, OR SEE SANDEL "FCS DEVIATION (INT RELAY)" DIAGRAM IF ADDITIONAL RECEIVERS ARE SWITCHED TO THE AUTOPILOT.

Notes:

- GARMIN SETUP ITEMS  
SOFTWARE MAIN 4.00 OR LATER  
MAIN ARINC-429 CONFIGURATION:  
IN 1: LOW, SANDEL EHSI  
OUT: LOW, GAMA 429 Graphics w/Int  
SDI: LNAV 1 (SDI1)  
SET VNAV LABELS TO ENABLE  
VOR/LOC/GS ARINC-429 CONFIGURATION:  
SPD RX: LOW  
SPD TX: LOW  
SDI: VOR/ILS 1 (SDI1)
- AS APPROPRIATE SET MAINTENANCE PAGE 7: GPS-1 AND/OR PAGE 8:  
SELECT GNS430 (ARINC), GNS500 (ARINC) or GTN (6XX/7XX)  
ANNUN SERIAL  
LAT DV SERIAL  
VERT DV SERIAL  
VERT ENA VERT DV FLAG  
ARINC 429 429 or 429H as needed  
APR ACTV ANNUN IN (if Autopilot is interfaced to P2-27)

- SET MAINTENANCE PAGE 5: NAV/ILS/DME-1 AND/OR PAGE 6 : NAV/ILS/DME-2 AS FOLLOWS:  
NAV 429 FR OR 429H FR AS NEEDED  
ENRGZ 429 OR 429H AS NEEDED  
LOC DV 429 OR 429H AS NEEDED  
G/S DV 429 OR 429H AS NEEDED
- GARMIN GTN SETUP:  
SOFTWARE MAIN 5.00 OR LATER  
SELECT "EFIS FORMAT 4" FOR THE ARINC 429 INPUT  
SELECT "HIGH" OR "LOW" SPEED FORMAT 3 FOR THE ARINC GPS 429 OUT  
SELECT "GAMA FORMAT 3" FOR THE ARINC GPS 429 OUT.  
SELECT HIGH OR LOW SPEED AS DESIRED.  
SELECT "LNAV 1" OR "LANAV 2" AS DESIRED.  
  
SELECT ON VOR/LOC/GS CONFIGURATION PAGE:  
SPEED: LOW OR HIGH AS NEEDED.  
SDI: VOR/ILS 1 OR VOR/ILS 2 AS DESIRED

THIS 6-WIRE INTERCONNECT PERFORMS THE FOLLOWING

- GPS/VLOC AUTOPILOT SWITCHING
- COURSE RESOLVER
- DEVIATION
- TO/FROM
- FLAGS
- ANNUNCIATORS
- MODE SWITCHING

<b>SANDEL</b> ®		Vista, Ca.
Category	SN4500 INSTALLATION DRAWING	
Title	SINGLE SN4500 SINGLE GNS430/530 GTN6XX/7XX	
Size B	Document Number	Rev
	<b>82009-10</b>	<b>D</b>
Create:	Mod:	Sheet 27

**SANDEL SN4500**

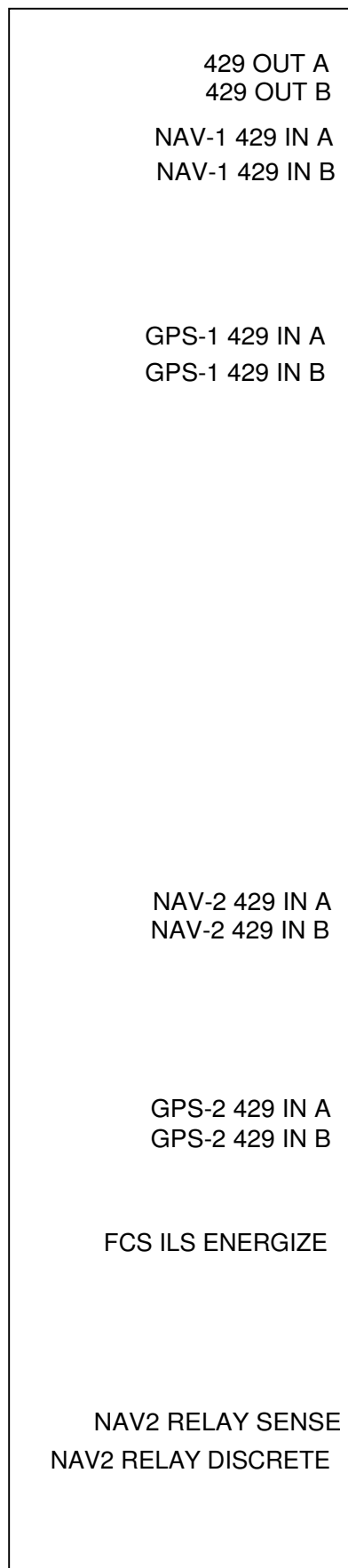

GNS 430	GNS 530	GTN 6XX 7XX
P4006	P5006	P1004

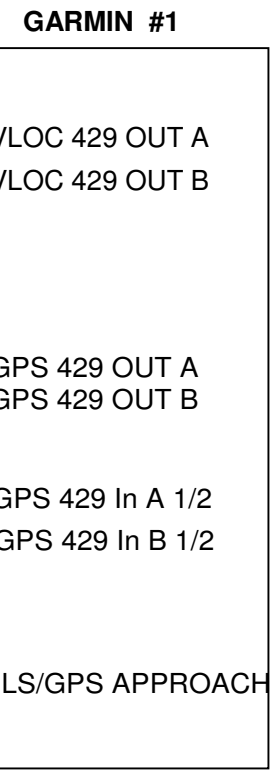

GNS 430	GNS 530	GTN 6XX 7XX
P4006	P5006	P1004

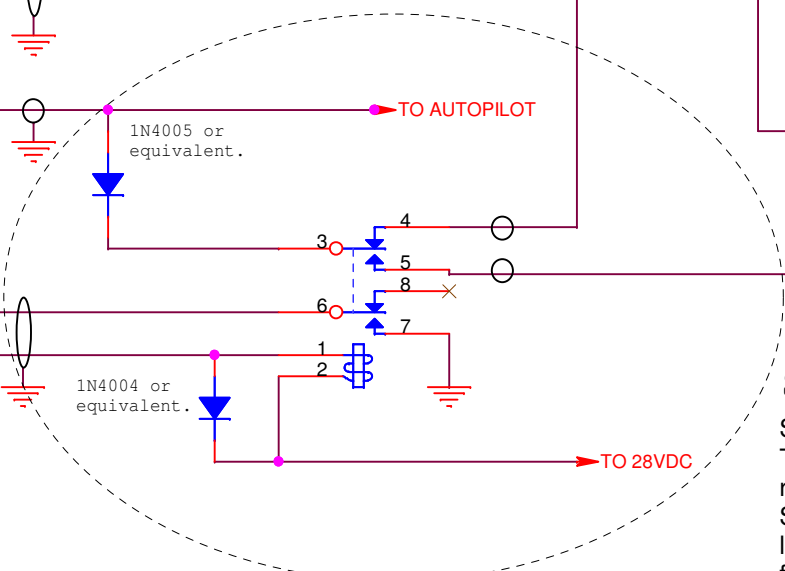
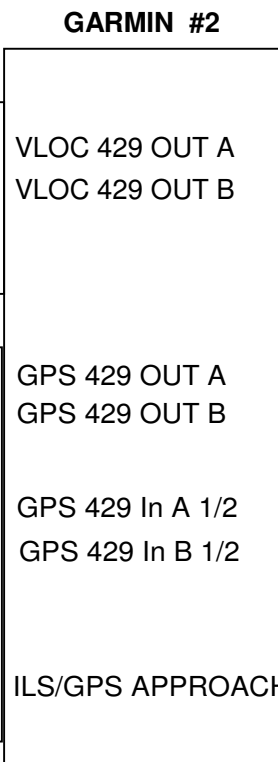

**SPECIAL NOTE**

SN4500 SUPPORTS GPS VNAV VIA ARINC 429 INTERFACE  
The connections and components shown in the dashed oval are for historical reference and are no longer necessary to support GPS vertical navigation when the SN4500 software has been updated to version 1.03 or later. After updating to 1.03 or later remove the 1N4005 diode. The remaining components may be left installed but for simplicity, removal is recommended.

**Connection to One Port ONLY!**  
**(48/49) OR (50/51) FOR GNS430**  
**(48/67) OR (447/66) FOR GTN 6XX/7XX**

**For GTN6XX/7XX - Connection to One Port ONLY!**  
**(10/29) OR (9/28)**

Notes:

- SN4500 MAINTENANCE PAGE ITEMS  
PAGE 5: NAV/ILS/DME 1  
NAV: 429 FR OR 429H FR AS NEEDED  
ENRGZ: 429 OR 429H AS NEEDED  
LOC DV: 429 OR 429H AS NEEDED  
GS DV: 429 OR 429H AS NEEDED  
PAGE 6: NAV/ILS/DME 2  
NAV: 429 FR OR 429H FR AS NEEDED  
ENRGZ: 429 OR 429H AS NEEDED  
LOC DV: 429 OR 429H AS NEEDED  
GS DV: 429 OR 429H AS NEEDED  
PAGE 7: GPS 1  
AS APPROPRIATE, SELECT GNS 430 (ARINC), GNS500 (ARINC), or GTN 6XX/7XX  
ANNUN: SERIAL  
LAT DV: SERIAL  
VERT DV: SERIAL  
VERT ENA: VERT DV FLAG  
ARINC 429: 429 OR 429H AS NEEDED  
APR ACTV: ANNUN IN (if autopilot is interfaced to P2-27)  
PAGE 8: GPS 2  
AS APPROPRIATE, SELECT GNS 430 (ARINC), GNS500 (ARINC), OR GTN 6XX/7XX  
ANNUN: SERIAL  
LAT DV: SERIAL  
VERT DV: SERIAL  
VERT ENA: VERT DV FLAG  
ARINC 429: 429 OR 429H AS NEEDED  
APP ACTV: ANNUN IN (if autopilot is interfaced to P2-27)  
DUAL GNS INSTALL ONLY  
PAGE 10: OBS/RELAY/CDI  
MODE: MASTER  
SENSE: NONE  
NS GPS2: NAV2 & GPS2

DATE	REV	COMMENTS
02-09-06	A	INITIAL RELEASE
10-28-06	B	UPDATED NOTES. Ref A/R 867.
01-29-07	C	ADDED CONNECTIONS FOR GNS ILS/GPS APPROACH
02-09-07	D	RELAY SENSE CONNECTIONS & SETTINGS
12-20-07	E	Added "SPECIAL NOTE" for 1.03 software update..
11-11-13	F	Updated for A/R 1378 GTN6XX/7XX ADDED Notes updated for GTN6XX/7XX
03-07-22	G	Corrected Note 1 VERT ENA setting to VERT DV FLAG. Corrected pin numbers on GTN 6XX/7XX P1001 connector. Added shield grounds at both sides.

COMPUTER CONTROLLED DRAWING  
DO NOT REVISE MANUALLY

- GARMIN SETUP ITEMS  
SOFTWARE MAIN 4.00 OR LATER  
MAIN ARINC-429 CONFIGURATION RECEIVER 1:  
IN 1: LOW, SANDEL EHSI  
OUT: LOW, GAMA 429 Graphics w/Int  
SDI: LNAV 1 (SDI1)  
Set VNAV Labels to Enable  
VOR/LOC/GS ARINC-429 CONFIGURATION:  
SPD RX: LOW  
SPD TX: LOW  
SDI: VOR/ILS 1 (SDI1)  
MAIN ARINC-429 CONFIGURATION RECEIVER 2:  
IN 1: LOW, SANDEL EHSI  
OUT: LOW, GAMA 429 Graphics w/Int  
SDI: LNAV 2 (SDI2)  
Set VNAV Labels to Enable  
VOR/LOC/GS ARINC-429 CONFIGURATION:  
SPD RX: LOW  
SPD TX: LOW  
SDI: VOR/ILS 2 (SDI2)
- Software main 5.00 or later: If the ARINC 429 IN 1 Port (P1001-48 & -67) is already used for another purpose, then any available ARINC 429 IN Port may be connected instead. Refer to section 4 of the current Garmin Installation Manual for the GTN-6XX/7XX systems.
- Garmin GTN setup:  
Select "EFIS Format 4" for the ARINC 429 input.  
Select "High" or "Low" speed as needed.  
Select "GAMA FORMAT 3" for the ARINC GPS 429 out.  
Select "High" or "Low" speed as needed.  
Select "LNAV 1" for #1 GTN & "LNAV 2" for #2 GTN.  
Select on VOR/LOC/GS Configuration Page:  
Speed: Low or High as needed.  
SDI: VOR/ILS 1 for #1 GTN SDI: VOR/ILS 2 for #2 GTN.

**SANDEL** Vista, Ca.

Category: **SN4500 INSTALLATION DRAWING**

Title: **SINGLE SN4500 DUAL GNS430(W)/530(W)/ GTN6XX/7XX**

Size B: Document Number **82009-10** Rev **G**

Create: Mod: Sheet 28

DATE	REV	COMMENTS
02-09-06	A	INITIAL RELEASE

COMPUTER CONTROLLED DRAWING  
DO NOT REVISE MANUALLY

### GPS SWITCH ANNUNCIATOR MATRIX

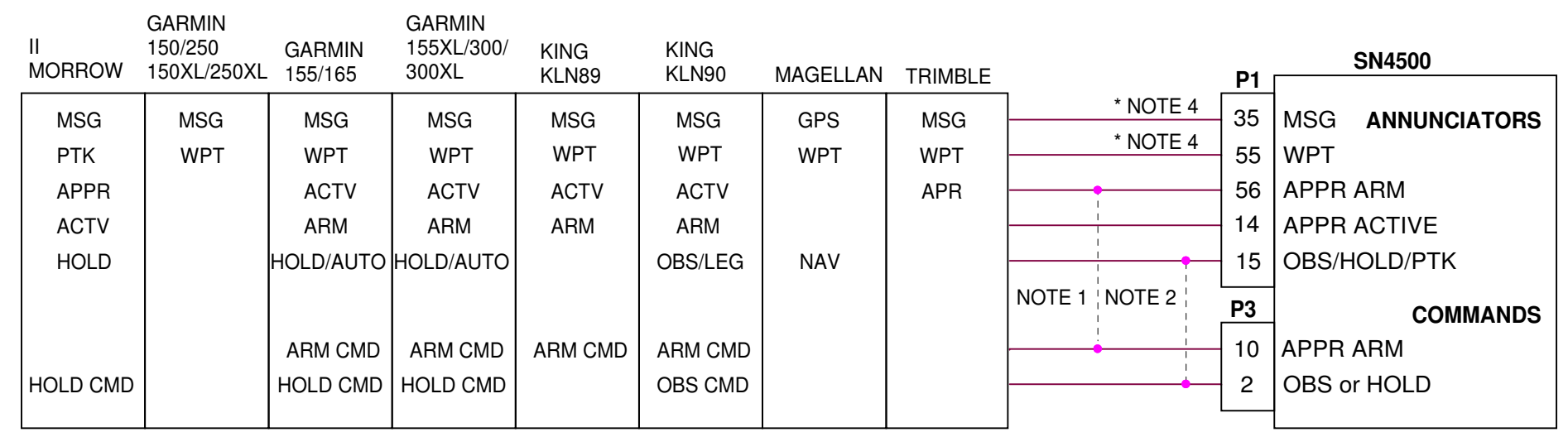

**NOTES:**

- 1: USED ONLY ON GARMIN 155/165 WHICH REQUIRED LATCHED ARM COMMANDS.
- 2: USED ON GARMIN AND KING RECEIVERS WHICH REQUIRE LATCHED MODE COMMANDS BUT NOT ON II-MORROW RECEIVERS.
3. SELECT APPROPRIATE RECEIVER ON THE SN4500 GPS MAINTENANCE PAGE. IF INSTALLED RECEIVER IS NOT SHOWN ON THIS MATRIX USE NEAREST COMPATIBLE SETTING OF THE SAME MANUFACTURER AND INSURE THE TEXT AND COLORS OF THE ON-SCREEN ANNUNCIATORS ARE ACCEPTABLE.
4. MSG AND WPT ANNUNCIATOR DISCRETES ARE NOT REQUIRED WITH ARINC-429 RECEIVERS.
5. GARMIN GNS-430 (NOT SHOWN) DOES NOT REQUIRE ANY DISCRETE ANNUNCIATOR WIRING.

<b>SANDEL</b> ®		Vista, Ca.
Category SN4500 INSTALLATION DRAWING		
Title GPS SWITCH/ANNUNCIATORS		
Size B	Document Number <b>82009-10</b>	Rev <b>A</b>
Create:	Mod:	Sheet 29

DATE	REV	COMMENTS
02-09-06	A	INITIAL RELEASE
10-28-06	B	UPDATED DIFF RESOLVER PIN NUMBERS. Ref A/R 867.

COMPUTER CONTROLLED DRAWING  
DO NOT REVISE MANUALLY

### COMMON NAV CONVERTER INTERCONNECTS

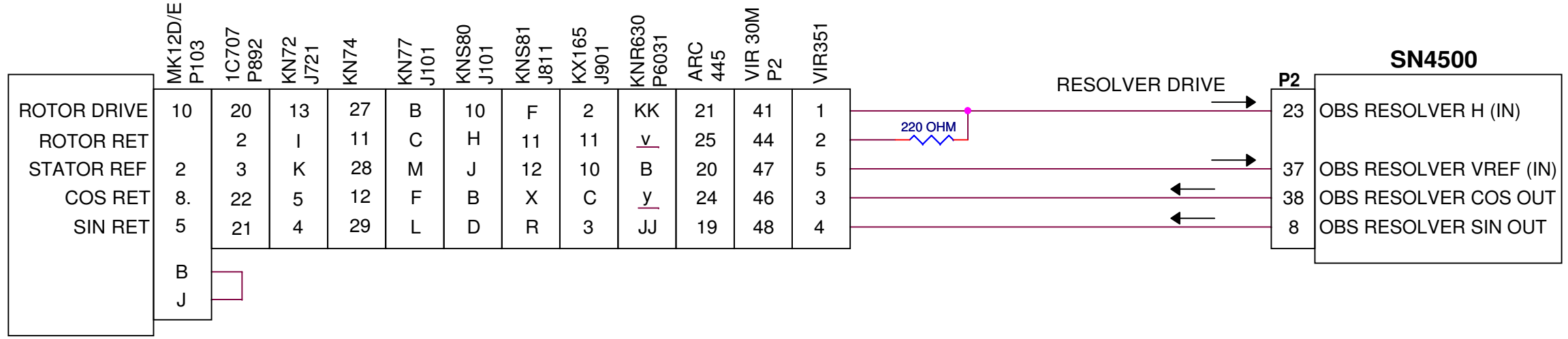

### CONNECTION TO OLDER RECEIVERS SUCH AS COLLINS 51R8, 51RV-1, KING KNR660 AND SIMILAR RECEIVERS. SEE NOTE 1.

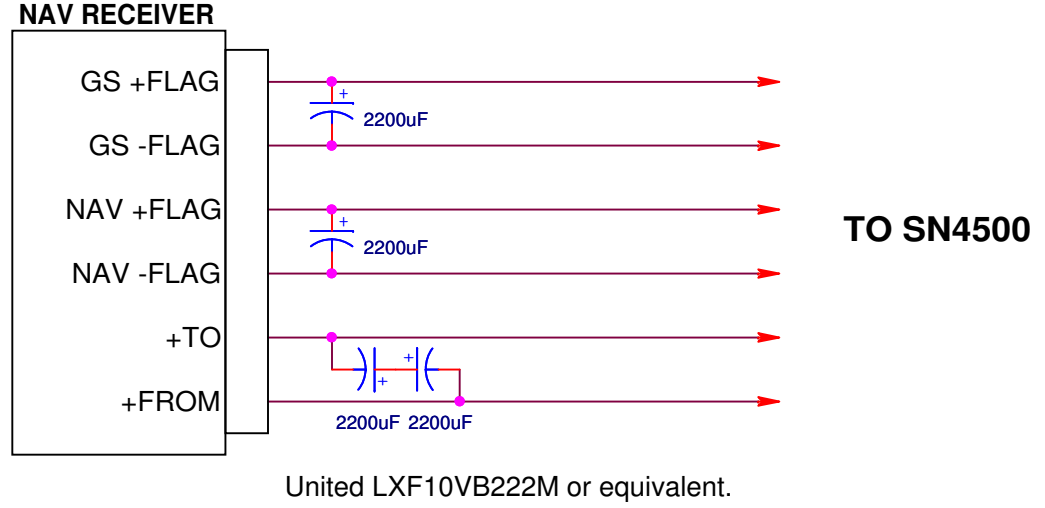

### ARINC NAV RECEIVERS KNR634 AND COLLINS VIR-30A (FOR VIR-30M SEE ABOVE) SEE NOTE 2.

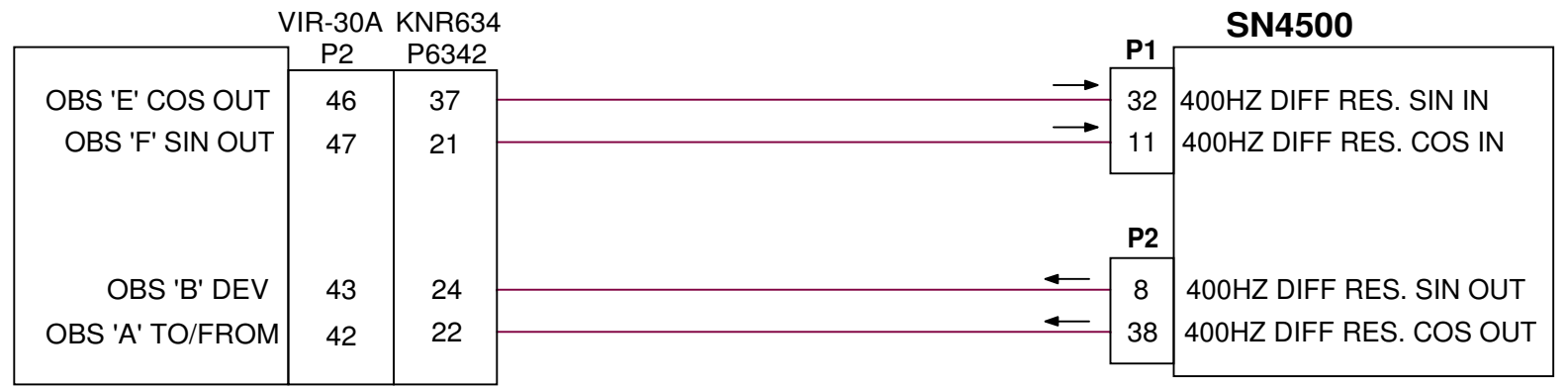

NOTES:

1. THE SN4500 REQUIRES DC FLAG SIGNALS. SOME VERY OLD RECEIVER DESIGNS OUTPUT UNSMOOTHED DC DUE TO A LACK OF FILTERING CAPACITORS. THE SN4500 WILL SHOW UNSTABLE FLAG OPERATION UNLESS SMOOTHING CAPACITORS ARE ADDED AS SHOWN. THE CAPACITORS CAN BE MOUNTED ON A TERMINAL BLOCK NEAR THE RECEIVERS. CONSULT THE RECEIVER SERVICE MANUAL SCHEMATICS AS REQUIRED.
2. FOR ARINC NAV RECEIVER USING 400HZ DIFFERENTIAL RESOLVER:
  - a) THE NAV RCVR AND SN4500 MUST BE ON THE SAME INVERTER.
  - b) ON OBS/RELAY/CDI MAINTENANCE PAGE SET OBS TYPE TO "DIFF A".

**SANDEL**® Vista, Ca.

Category: SN4500 INSTALLATION DRAWING

Title: RESOLVER INTERCONNECT

Size B Document Number: **82009-10** Rev **B**

Create: Mod: Sheet 30

DATE	REV	COMMENTS
02-09-06	A	INITIAL RELEASE
10-28-06	B	Pin number corrections. Ref A/R 867.

COMPUTER CONTROLLED DRAWING  
DO NOT REVISE MANUALLY

### ADF RECEIVER 1/2 INTERCONNECT

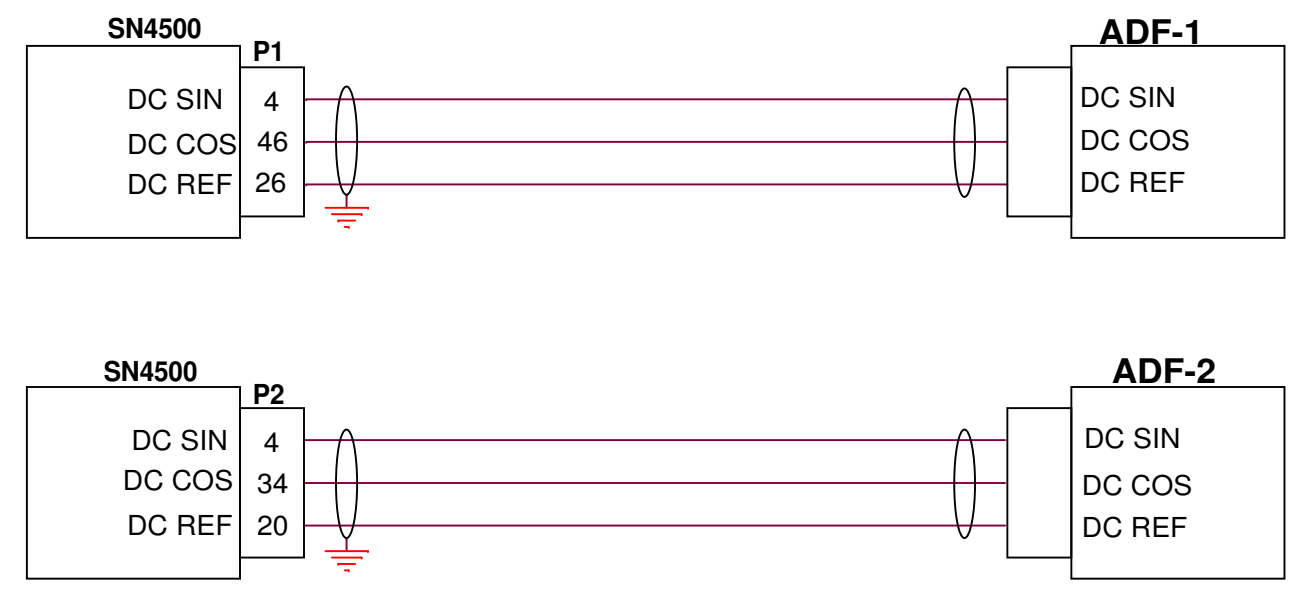

### 400HZ ADF RECEIVERS 1&2

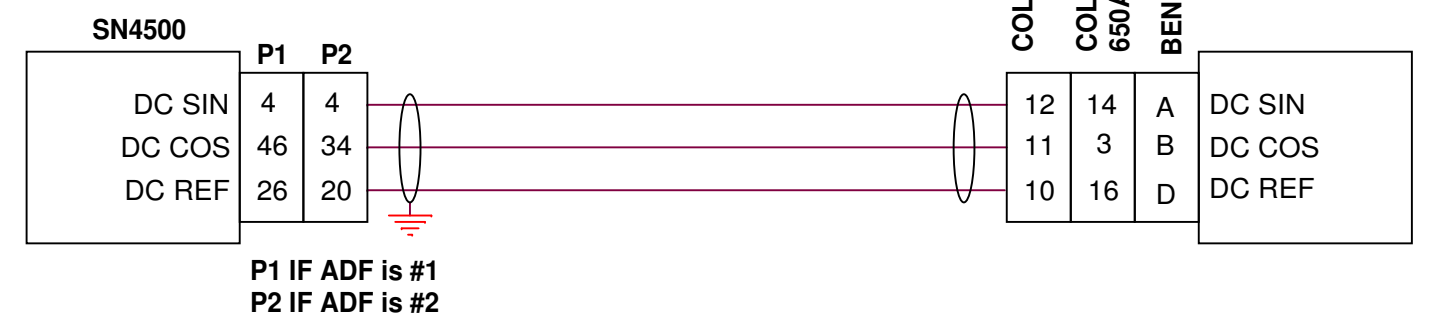
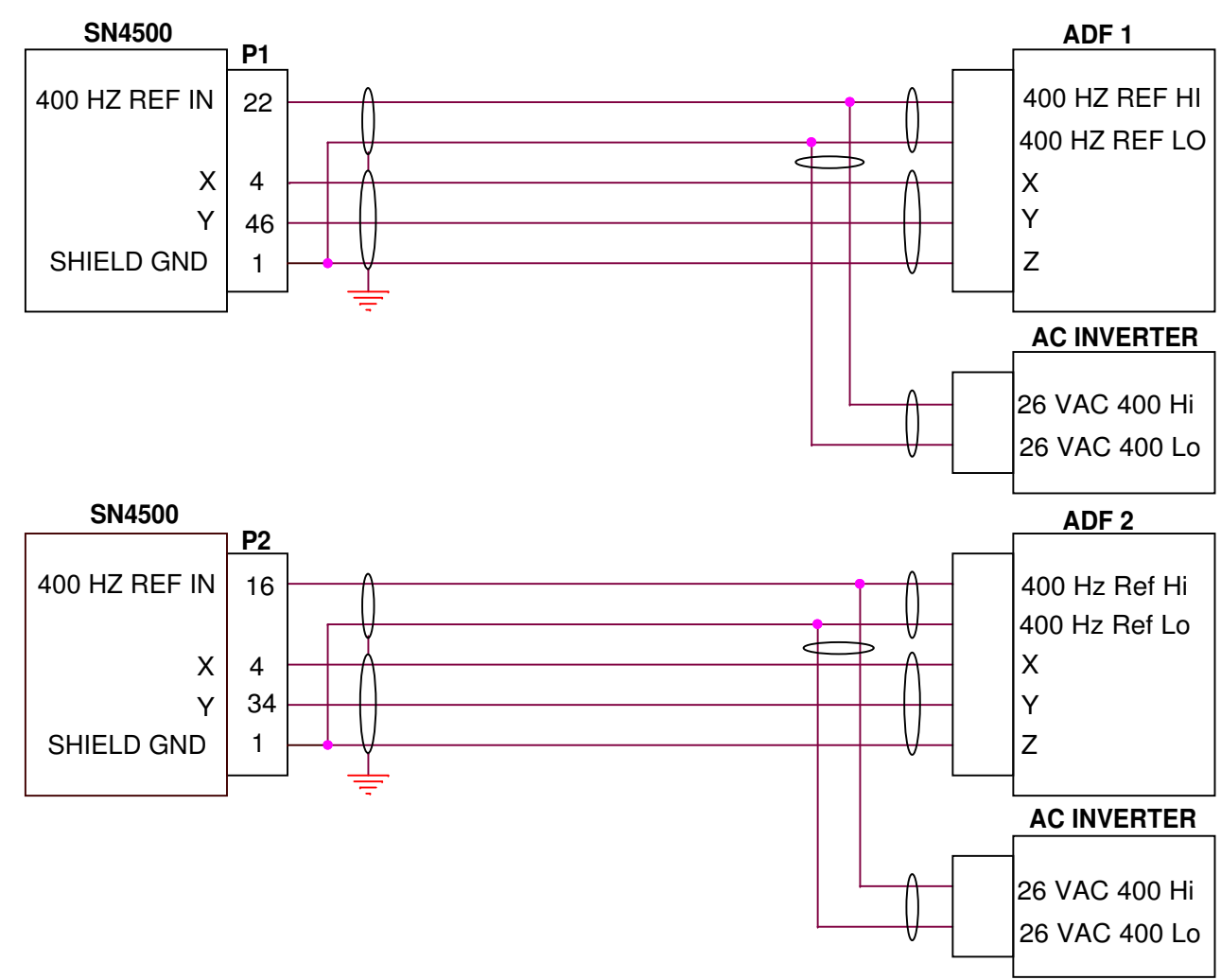

- NOTES:  
1. SELECT APPROPRIATE SETUP DATA ON ADF INSTALLATION PAGE.

<b>SANDEL</b> ®		Vista, Ca.
Category	SN4500 INSTALLATION DRAWING	
Title	ADF	
Size B	Document Number	Rev
	<b>82009-10</b>	<b>B</b>
Create:	Mod:	Sheet 31



DATE	REV	COMMENTS
02-09-06	A	INITIAL RELEASE

COMPUTER CONTROLLED DRAWING  
DO NOT REVISE MANUALLY

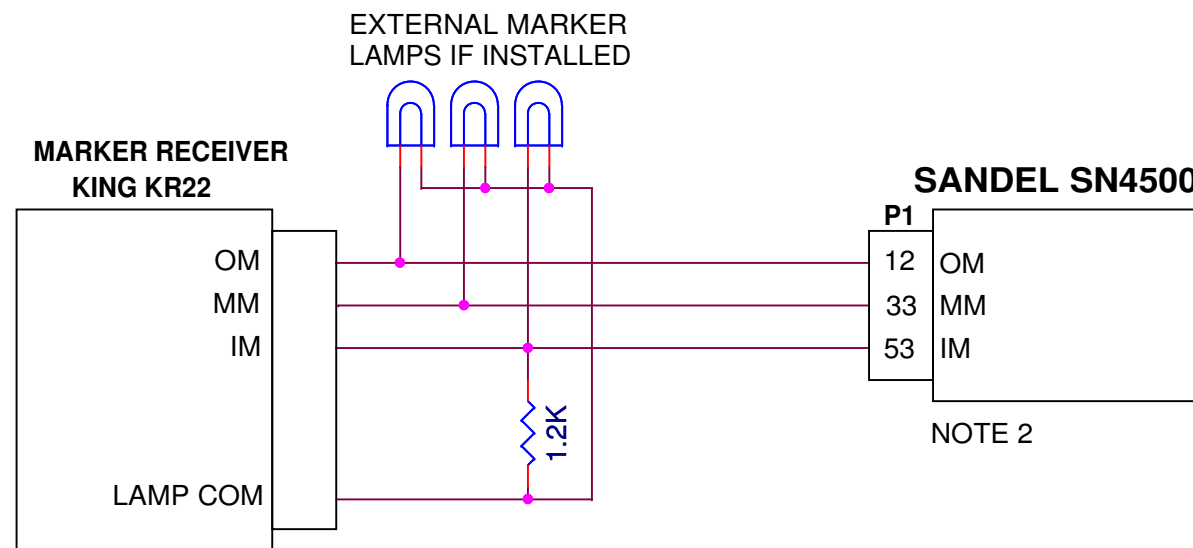
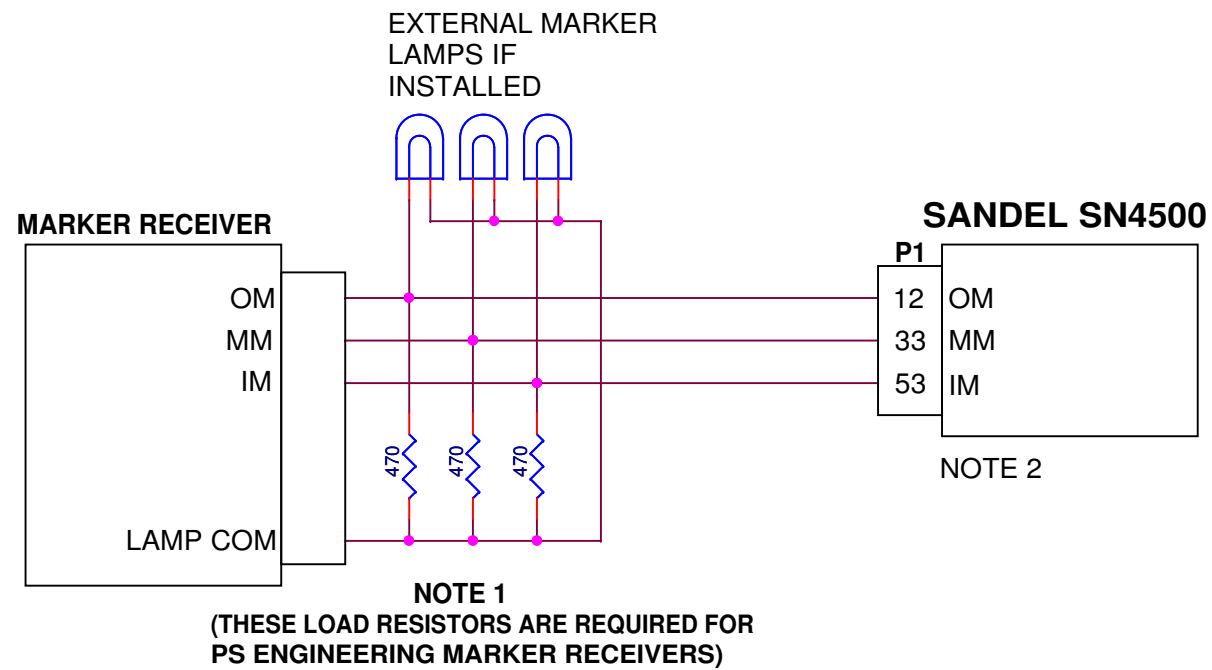

NOTES:

1. THESE LOAD RESISTORS ARE REQUIRED FOR PS ENGINEERING MARKER RECEIVERS. RECOMMENDED FOR OTHER RECEIVERS TO PREVENT FAILURE OF THE SN4500 INDICATION IF THE ASSOCIATED MARKER LIGHT BULB FAILS.
2. SET MARKERS TO ACTIVE H OR ACTIVE L ON ADF1/ADF2/MKR MAINTENANCE PAGE

<b>SANDEL</b> ®		Vista, Ca.
Category	SN4500 INSTALLATION DRAWING	
Title	MARKER BEACON	
Size B	Document Number	Rev
	<b>82009-10</b>	<b>A</b>
Create:	Mod:	Sheet 32

**SINGLE KING SERIAL DIGITAL DME USING KDI572  
(ANY KING SERIAL DME PERMISSABLE)**

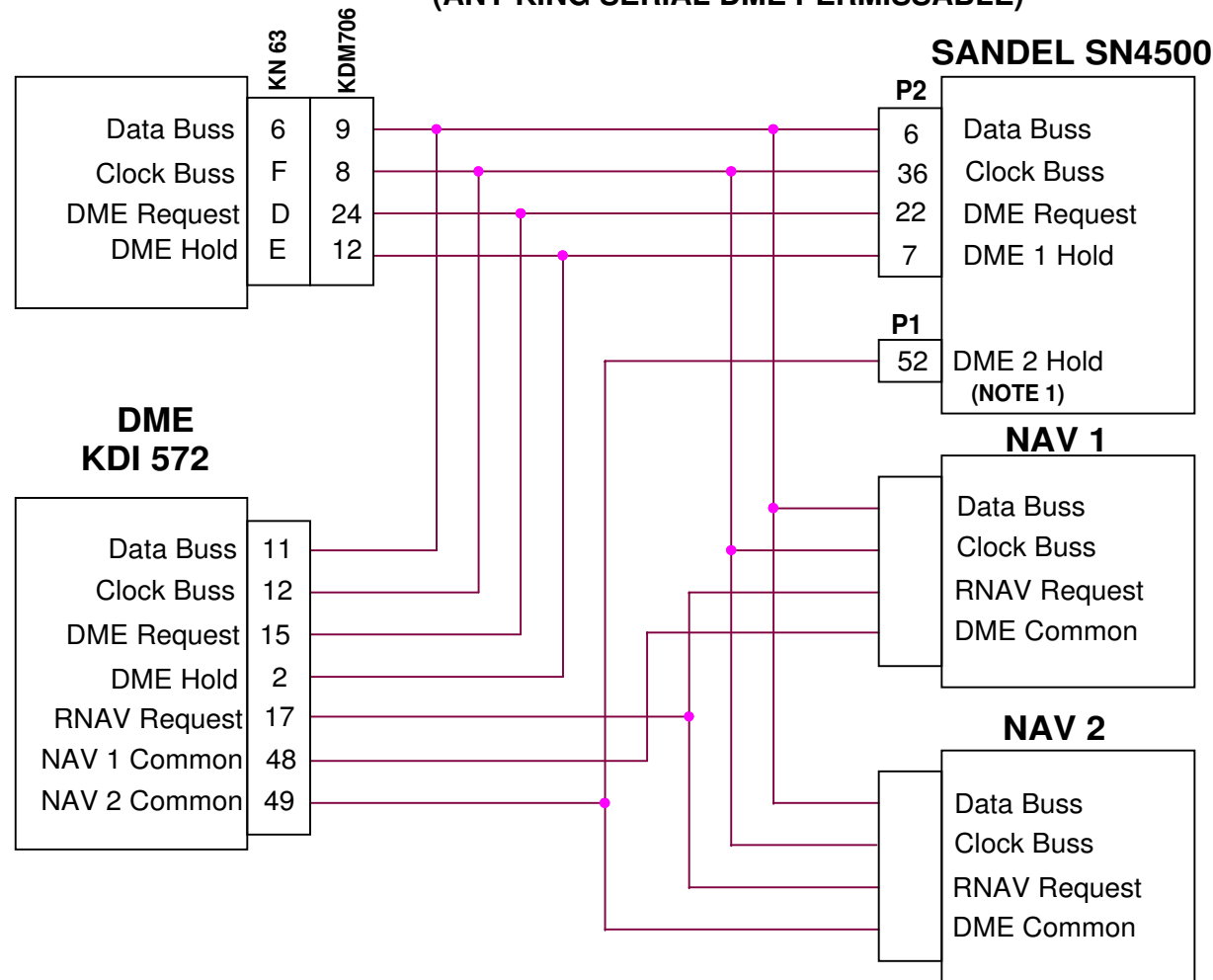

**SINGLE KING SERIAL DIGITAL DME WITH SELF CONTAINED CONTROLLER  
(KN64 SHOWN FOR REFERENCE, KN62/KN62A PERMISSABLE)**

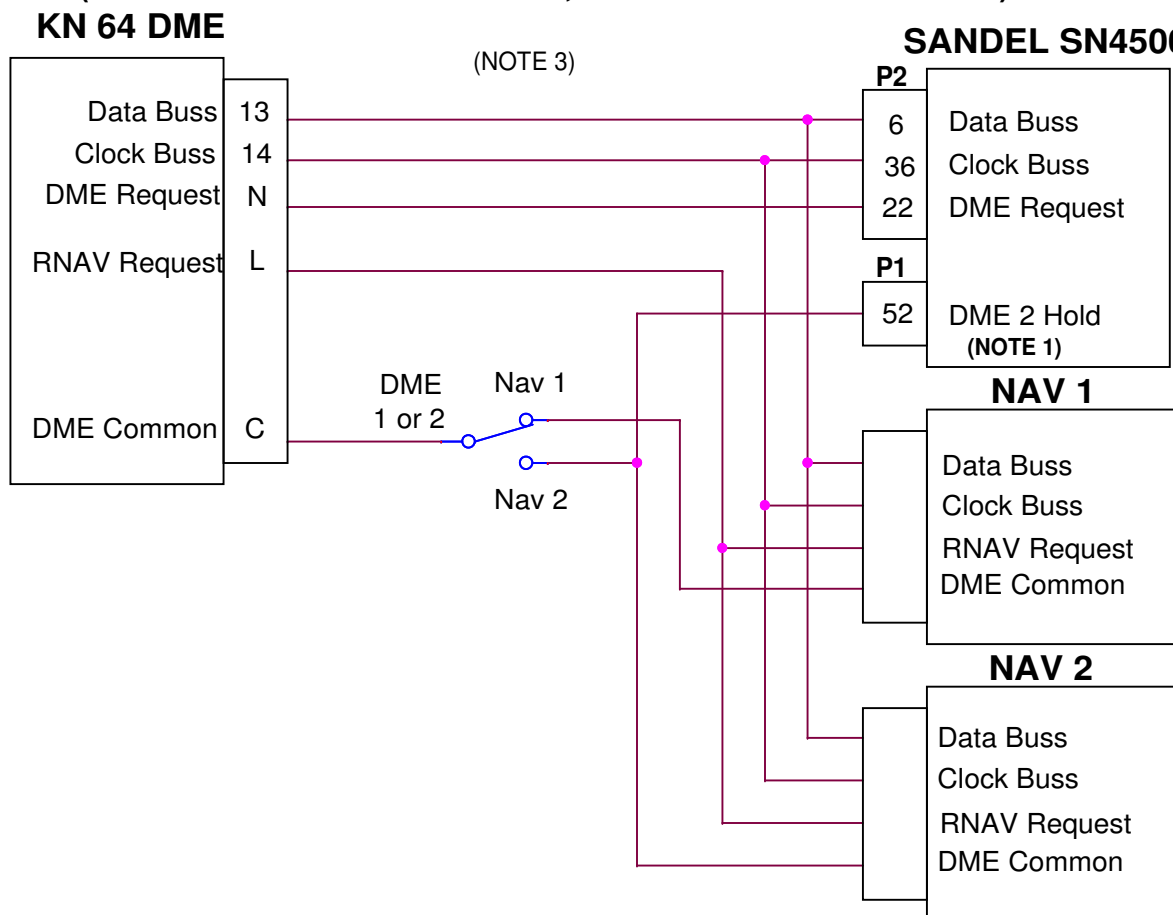

DATE	REV	COMMENTS
02-09-06	A	INITIAL RELEASE
10-28-06	B	FORMAT. Ref A/R 867.
11-17-06	C	Corrected label on P1-52 from DME 1 Hold to DME 2 Hold. Ref A/R 950.

COMPUTER CONTROLLED DRAWING  
DO NOT REVISE MANUALLY

**NOTES:**

1. IN A SINGLE DME CONFIGURATION THE SN4500 DETECTS BOTH DME HOLD AND NAV-1/NAV-2 ASSIGNMENT. WHEN NAV-2 IS CHANNLED THE DME READOUT WILL ASSOCIATE WITH THE BEARING POINTER NAV-2 SELECTION. IF THE DME IS NOT ASSIGNABLE LEAVE THE CORRESPONDING PIN UNCONNECTED. SET DME TO LO FR DME1 ON NAV/ILS/DME 2 MAINTENANCE PAGE TO ENABLE NAV2 DME DISPLAY.
2. IN A DUAL DME CONFIGURATION THE SN4500 CAN ONLY DETECT DME HOLD. IT ALWAYS ASSOCIATES DME-1 WITH NAV-1 AND DME-2 WITH NAV-2.
3. THE SN4500 WILL SUPPORT REMOTE DISPLAY OF KN62/64 DME'S. CONNECT AS SHOWN, TAKING "DME REQ" FROM REAR CONNECTOR PIN-N. THE KN62/64 DO NOT HAVE A HOLD OUTPUT THEREFORE NO HOLD ANNUNCIATION IS POSSIBLE.

**DUAL KING SERIAL DIGITAL DME'S.**

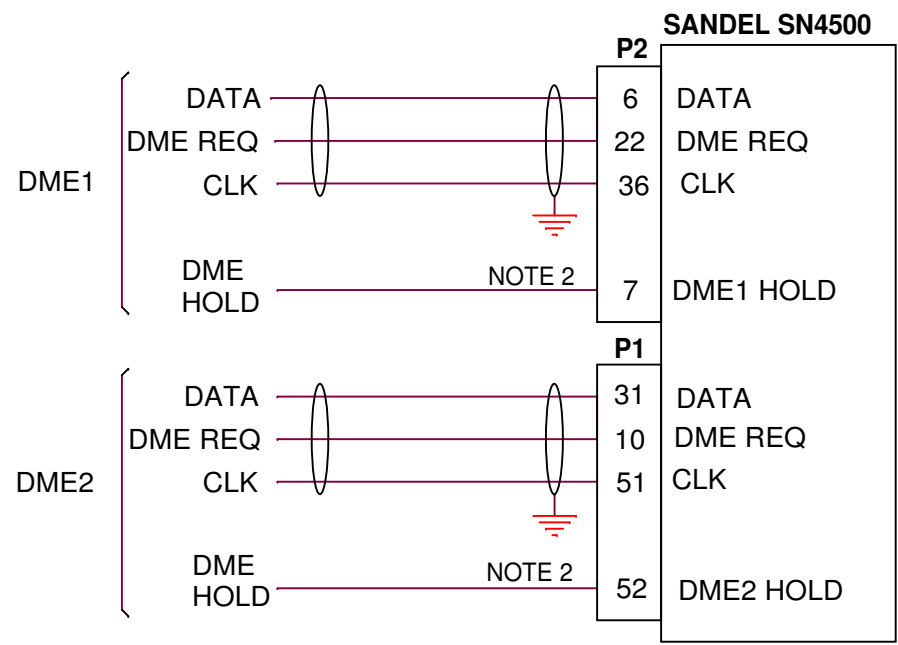

**ANALOG DME**

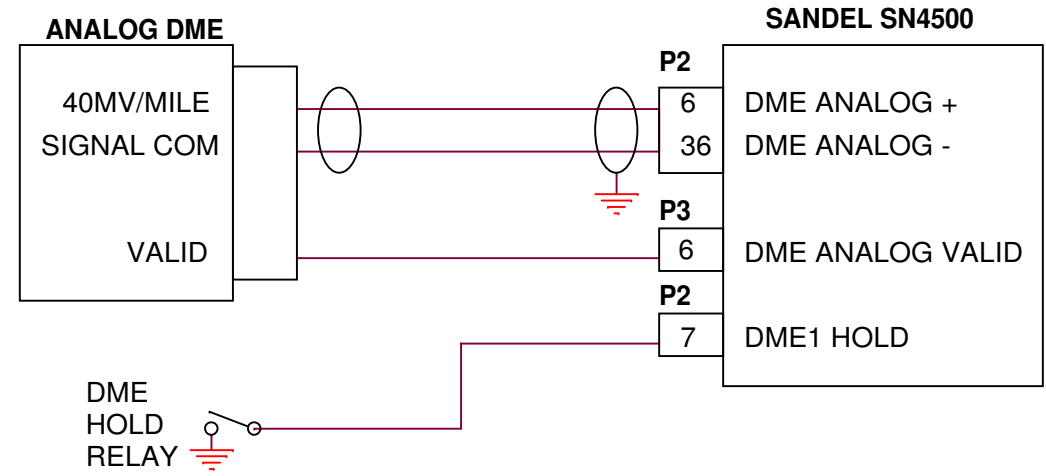

**SANDEL**® Vista, Ca.

Category: SN4500 INSTALLATION DRAWING

Title: **DME, KING SERIAL AND ANALOG**

Size B Document Number: **82009-10** Rev: **C**

Create: Mod: Sheet 33

DATE	REV	COMMENTS
02-09-06	A	INITIAL RELEASE
11-17-06	B	Corrected label on P1-52 from DME 1 Hold to DME 2 Hold. Ref A/R 950.

COMPUTER CONTROLLED DRAWING  
DO NOT REVISE MANUALLY

**SINGLE ARINC 568 DME. COLLINS DME-40 SHOWN FOR REFERENCE.**

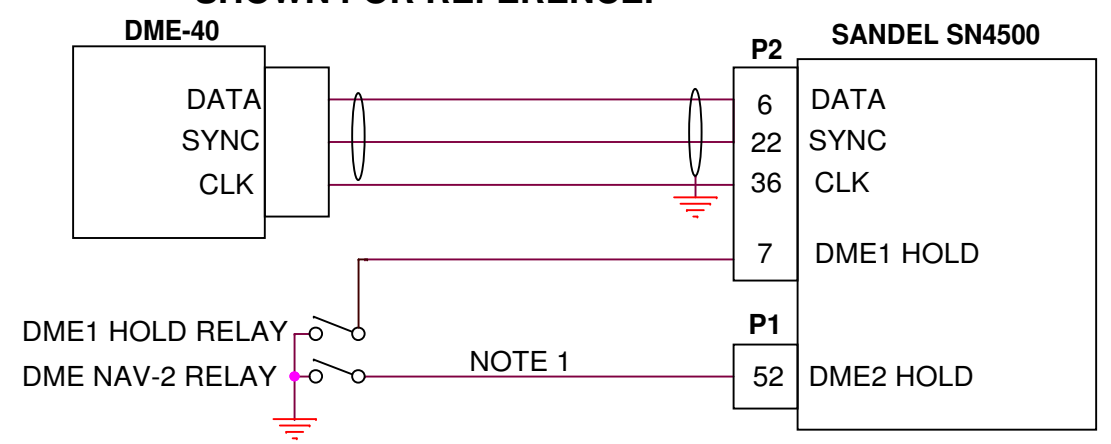

**DUAL ARINC 568 DME'S. COLLINS DME-40 SHOWN FOR REFERENCE**

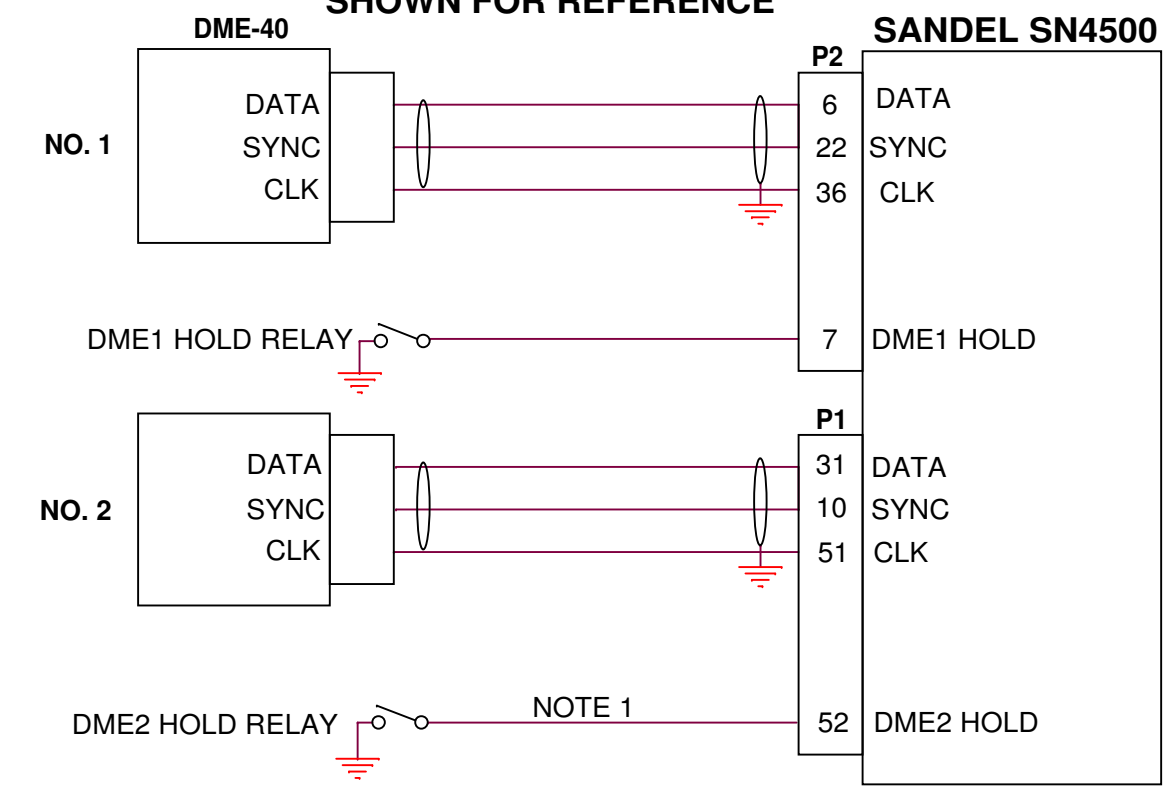

**NOTES:**

1. IN A SINGLE DME CONFIGURATION THE SN4500 DETECTS BOTH DME HOLD AND NAV-1/NAV-2 ASSIGNMENT FROM THE INSTALLED SWITCHING RELAYS. WHEN NAV-2 IS CHANNLED THE DME READOUT WILL ASSOCIATE WITH THE BEARING POINTER NAV-2 SELECTION. IF THE DME IS NOT ASSIGNABLE LEAVE THE CORRESPONDING PIN UNCONNECTED. SET DME TO LO FR DME1 ON NAV/ILS/DME 2 MAINTENANCE PAGE TO ENABLE NAV2 DME DISPLAY.
2. IN A DUAL DME CONFIGURATION THE SN4500 CAN ONLY DETECT DME HOLD. IT ALWAYS ASSOCIATES DME-1 WITH NAV-1 AND DME-2 WITH NAV-2.

<b>SANDEL</b> ®		Vista, Ca.
Category SN4500 INSTALLATION DRAWING		
Title DME: ARINC 568		
Size B	Document Number <b>82009-10</b>	Rev <b>B</b>
Create:	Mod:	Sheet 34

DATE	REV	COMMENTS
02-09-06	A	INITIAL RELEASE
10-28-06	B	CORRECTED TCAS PIN NUMBERS Ref A/R 867.
07-19-13	C	ADDED KTA-810 INTERFACE

COMPUTER CONTROLLED DRAWING  
DO NOT REVISE MANUALLY

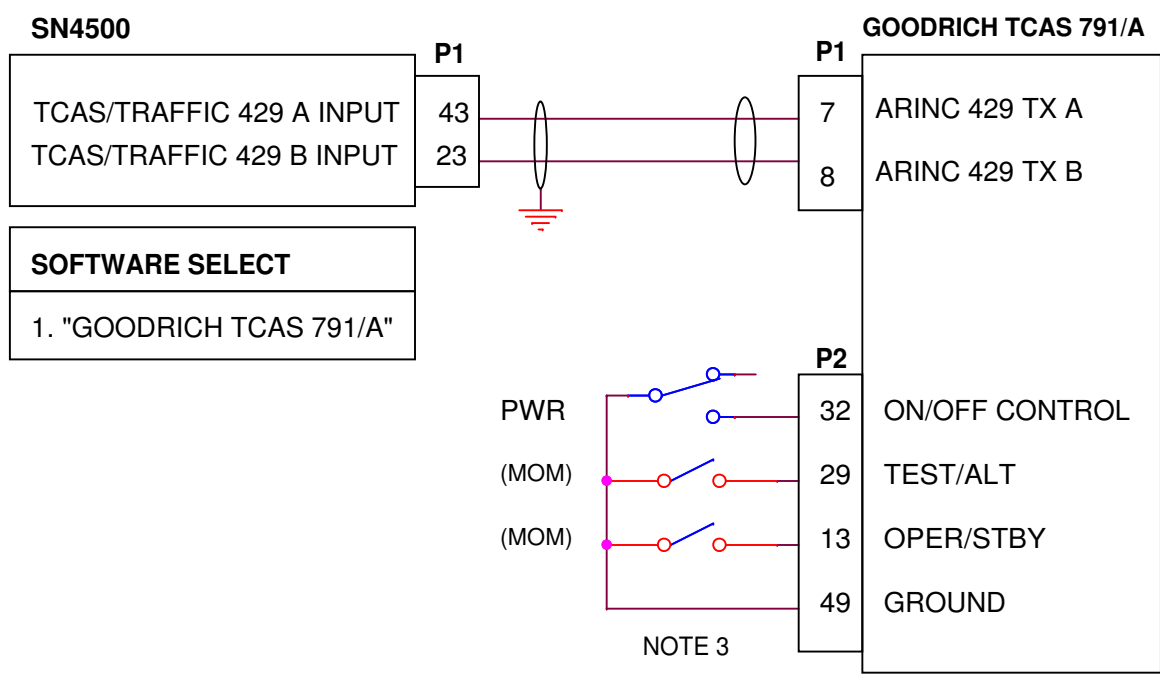

**TCAS 791/A SETUP**  
DISPLAY TYPE: SET TO  
"ARINC735 TYPE II"

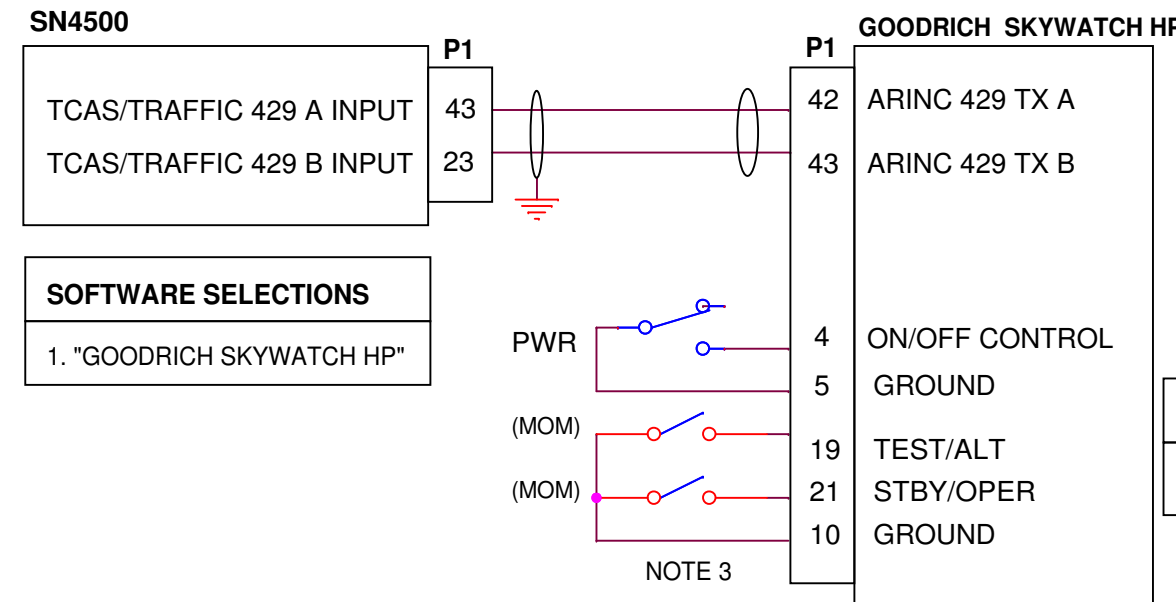

**SKYWATCH HP SETUP**  
DISPLAY TYPE "STANDARD  
TYPE 5"

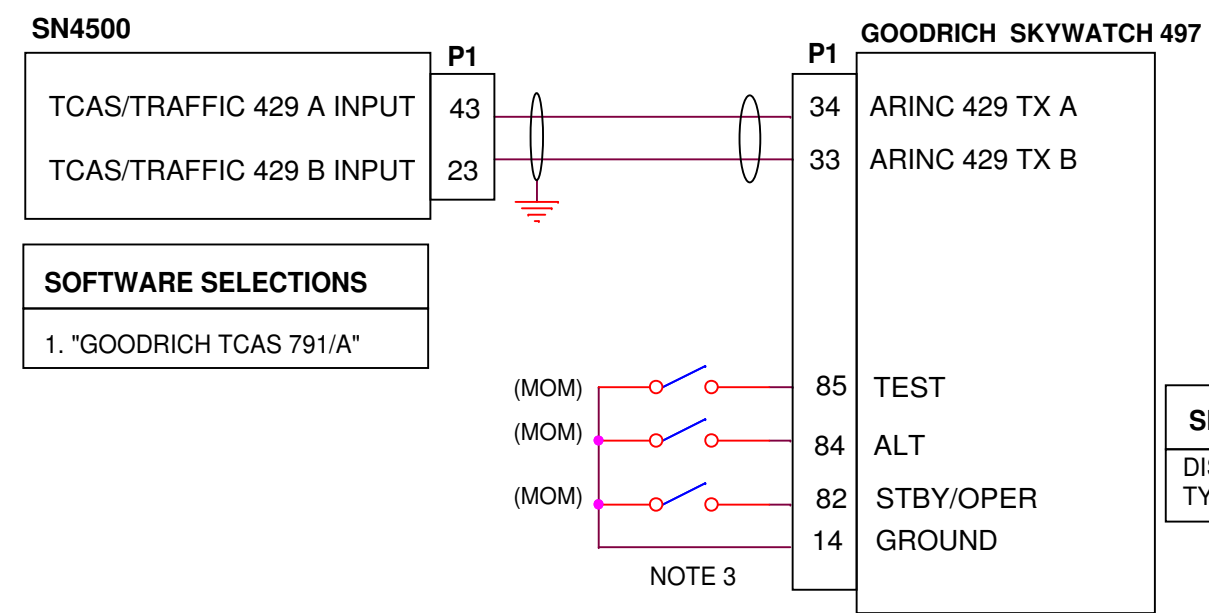
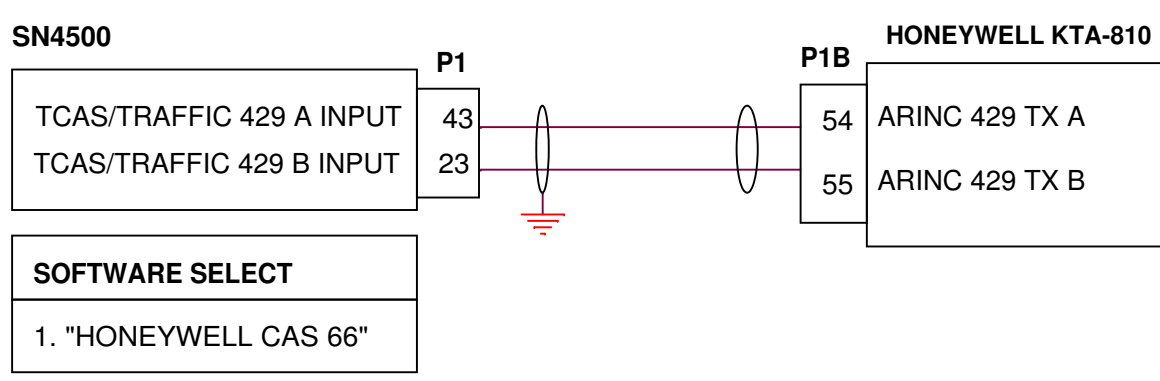
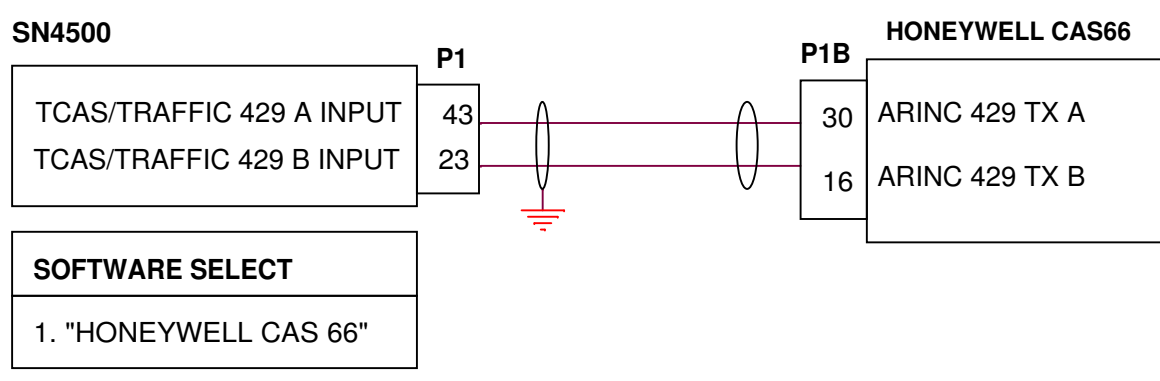

**SKYWATCH 497 SETUP**  
DISPLAY TYPE "ARINC 735  
TYPE I"

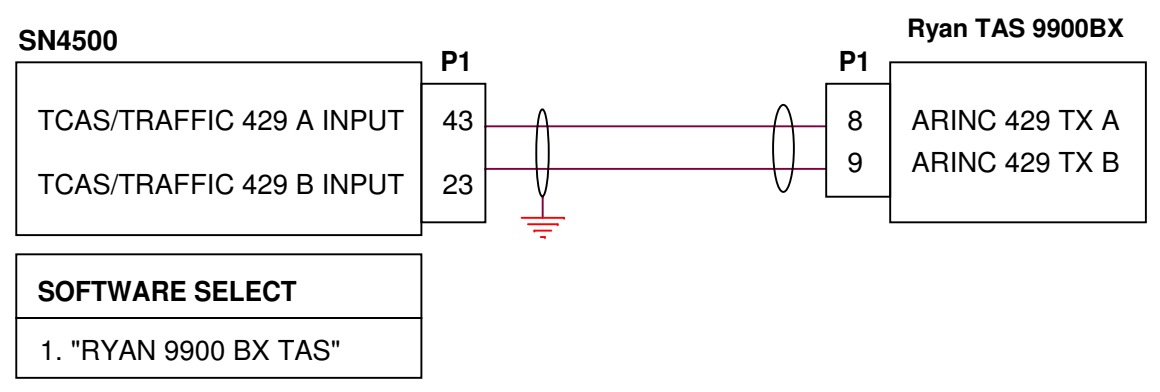

- NOTES:**
1. SEE MANUFACTURERS INSTALLATION MANUALS FOR COMPLETE WIRING INTERFACE.
  2. TRAFFIC INTERFACE REQUIRES PURCHASE OF KEY CODE.
  3. SWITCHES REQUIRED IF SN4500 IS PRIMARY DISPLAY.
  4. THE SN4500 MAY BE USED AS A SOURCE OF MAGNETIC HEADING IF REQUIRED BY THE TCAS PROCESSOR. REFER TO COMPASS BOOTSTRAP DRAWING FOR INTERFACE.

**SANDEL**® Vista, Ca.

Category: SN4500 INSTALLATION DRAWING

Title: TCAS / TRAFFIC

Size B Document Number: **82009-10** Rev **C**

Create: Mod: Sheet 35

DATE	REV	COMMENTS
02-09-08	A	INITIAL RELEASE

COMPUTER CONTROLLED DRAWING  
DO NOT REVISE MANUALLY

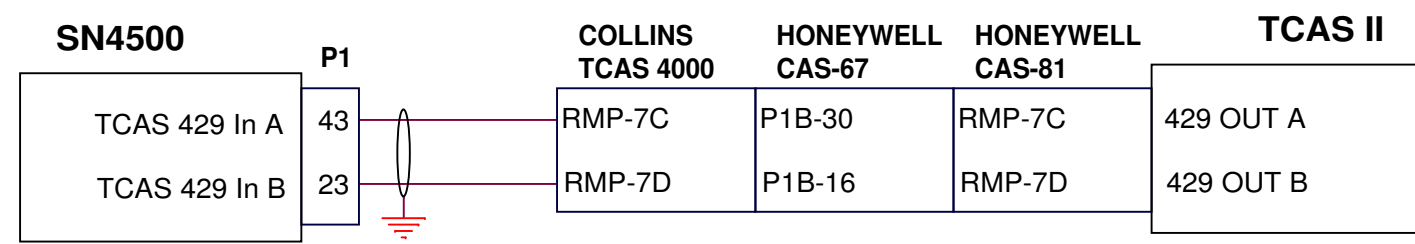

**NOTE:**

1. SEE MANUFACTURERS INSTALLATION MANUALS FOR COMPLETE WIRING INTERFACE.
2. SN4500 CAN ONLY BE USED AS A SECONDARY DISPLAY.
3. TRAFFIC INTERFACE REQUIRES PURCHASE OF KEY CODE.

<b>SANDEL</b> ®		Vista, Ca.
Category	SN4500 INSTALLATION DRAWING	
Title	TCAS II	
Size B	Document Number	Rev
	<b>82009-10</b>	<b>A</b>
Create:	Mod:	Sheet 36

DATE	REV	COMMENTS
02-09-06	A	INITIAL RELEASE
10-28-06	B	UPDATED NOTE 4. Ref A/R 867.

COMPUTER CONTROLLED DRAWING  
DO NOT REVISE MANUALLY

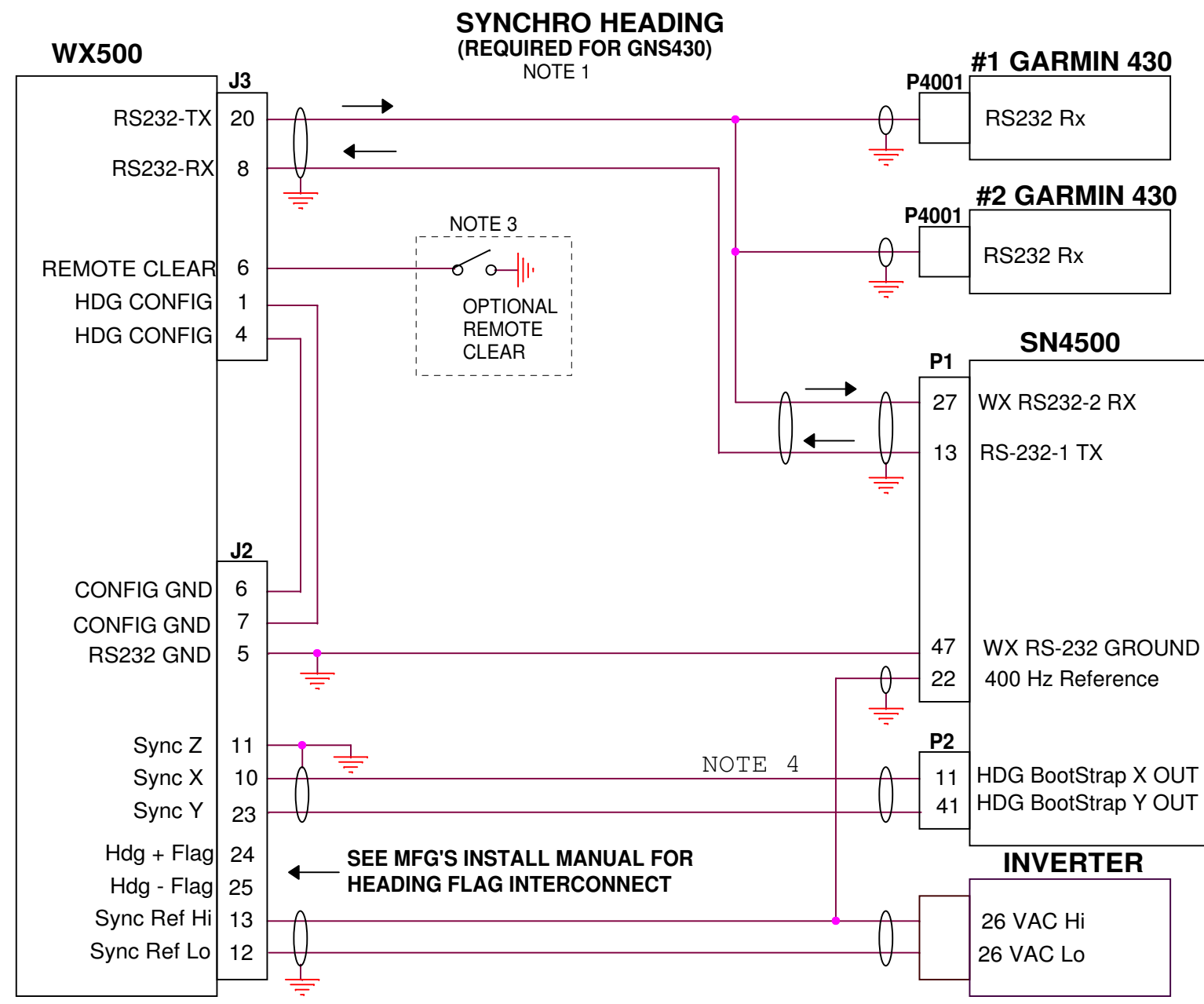
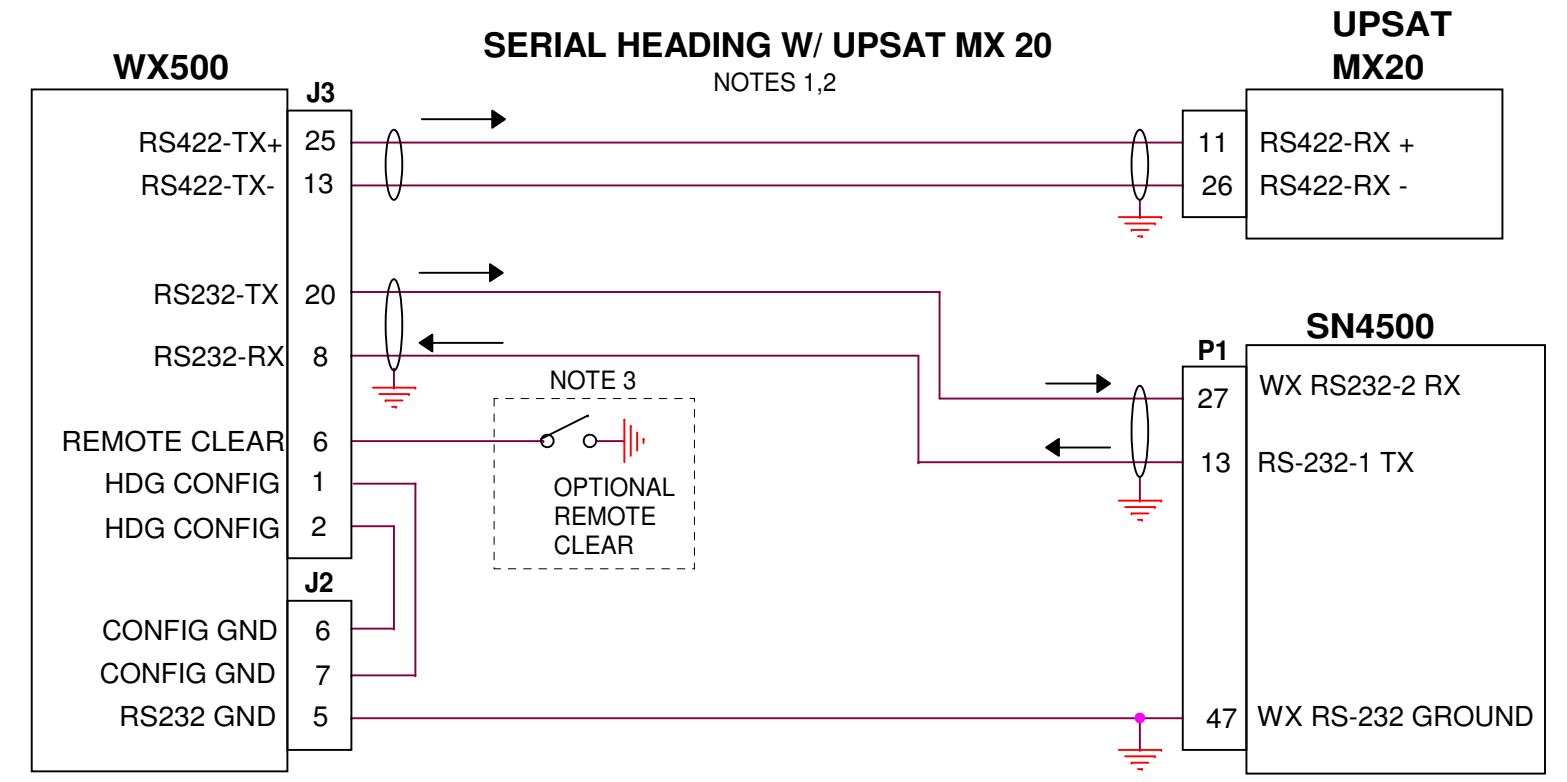
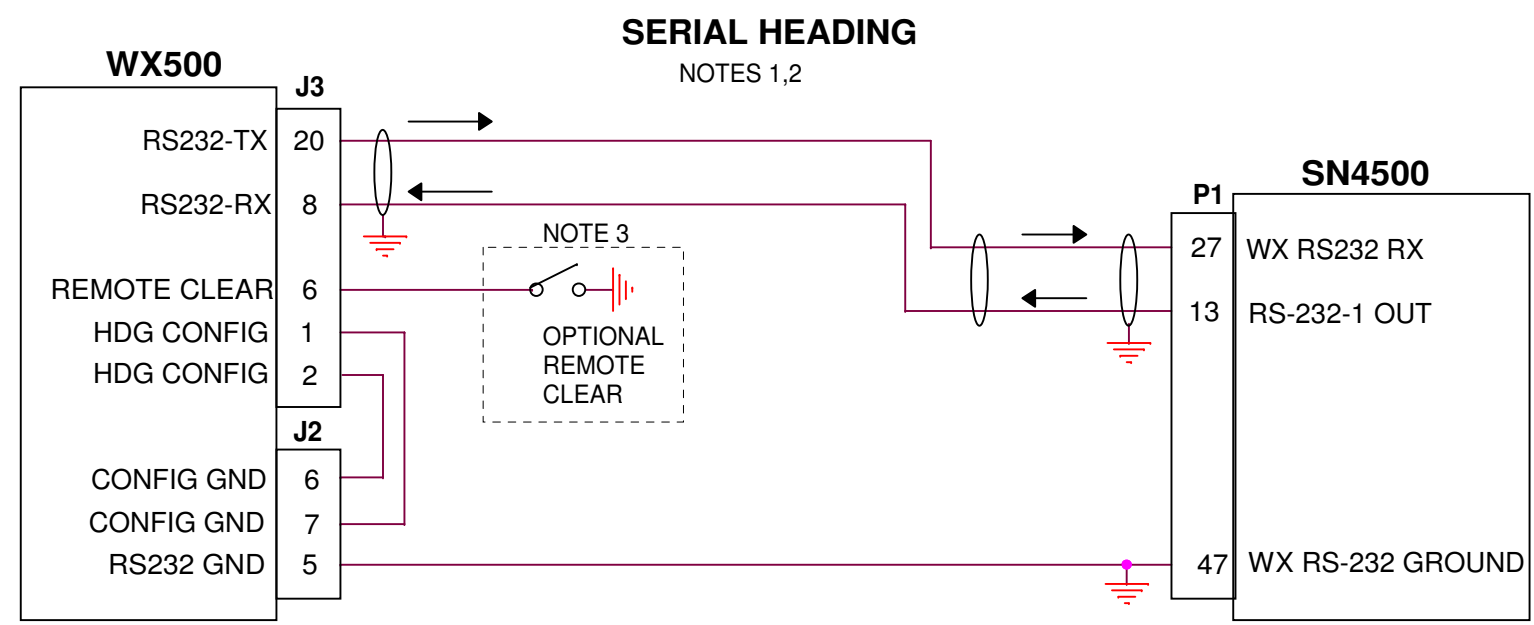

**NOTES:**

1. WX500 ALLOWS ONLY ONE UNIT TO BE MASTER. THE "MASTER" CONTROLS CELL/STRIKE MODE AND REMOTE CLEAR THROUGH THE SERIAL PORT.
2. WX-500 HEADING CONFIGURATION IS SET TO "SERIAL" (HEADING RECEIVED FROM SN4500)
3. A REMOTE-CLEAR SWITCH CONNECTED TO THE WX-500 CAN BE USED TO CLEAR THE CELL/STRIKE DISPLAY. THIS FUNCTION IS ALSO AVAILABLE ON THE FRONT PANEL OF THE SN4500 VIA SOFTKEYS.
4. TO ACTIVATE THE HEADING BOOTSTRAP OUTPUT, SET THE BOOTSTRAP SELECTION TO OTHER THAN NONE.

<b>SANDEL</b> ® Vista, Ca.	
Category	SN4500 INSTALLATION DRAWING
Title	<b>WX-500</b>
Size B	Document Number <b>82009-10</b>
Rev	<b>B</b>
Create:	Mod: Sheet 37

DATE	REV	COMMENTS
02-09-06	A	INITIAL RELEASE
10-28-06	B	FORMAT AND SIGNAL NAME FOR CLARITY. Ref A/R 867.
12-20-07	C	Added WSI AV 300/350 connections.
03-07-22	D	Added note regarding discontinuation of WSI service.

COMPUTER CONTROLLED DRAWING  
DO NOT REVISE MANUALLY

### WSI Receiver with SN4500 as sole display device.



Note:

WSI mode must be set to "No Flow Control".  
See WSI manual for instructions.

**Notes:**

1. WSI InFlight data link weather service has been discontinued. This drawing is included for reference purposes.

### WSI Receiver with SN4500 as secondary display device, listen only.

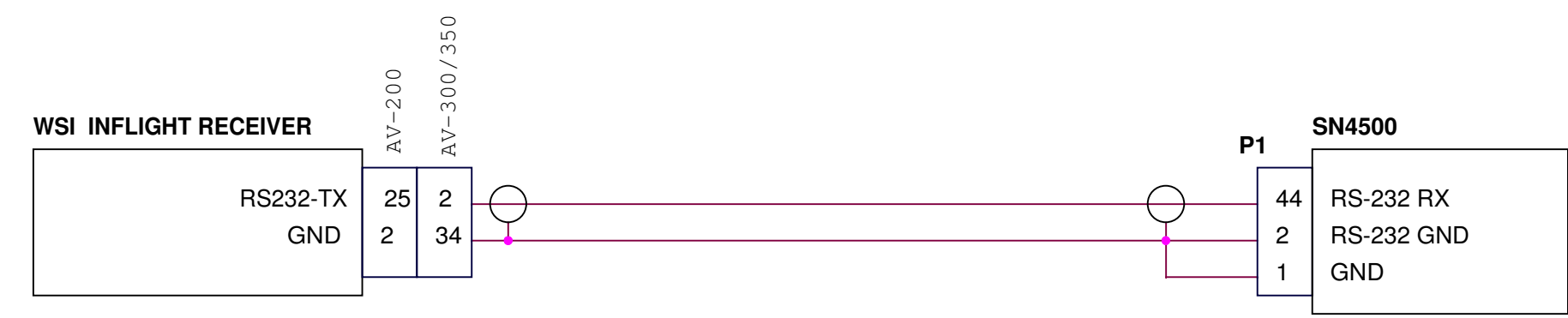

<b>SANDEL</b> ®		Vista, Ca.
Category	<b>SN4500 INSTALLATION DRAWING</b>	
Title	<b>WSI Data Link Receiver</b>	
Size B	Document Number <b>82009-10</b>	Rev <b>D</b>
Create:	Mod:	Sheet 38

DATE	REV	COMMENTS
10-28-08	A	INITIAL RELEASE

COMPUTER CONTROLLED DRAWING  
DO NOT REVISE MANUALLY

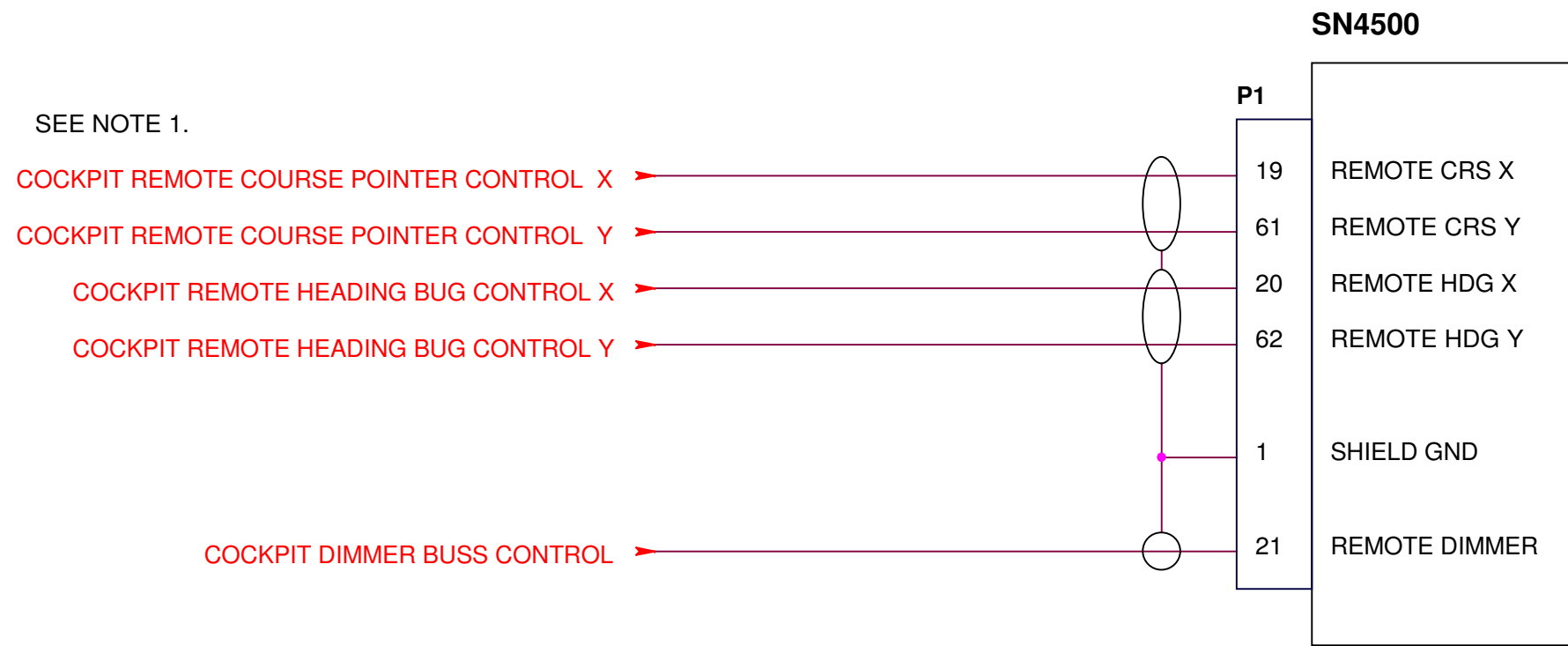

NOTES:

1. REMOTE COURSE AND HEADING X/Y CONTROL SIGNALS MUST BE REFERENCED TO 26VAC REFERENCE INVERTER CONNECTED TO P1-22 SN4500 INVERTER EXCITATION.

<b>SANDEL</b> ®		Vista, Ca.
Category <b>SN4500 INSTALLATION DRAWING</b>		
Title <b>COCKPIT REMOTE INTERFACES</b>		
Size B	Document Number <b>82009-10</b>	Rev <b>A</b>
Create:	Mod:	Sheet 39



DATE	REV	COMMENTS
12-DEC-07	A	INITIAL RELEASE
10-FEB-12	B	P1 PIN 20 WAS 30 A/R 1220

COMPUTER CONTROLLED DRAWING  
DO NOT REVISE MANUALLY

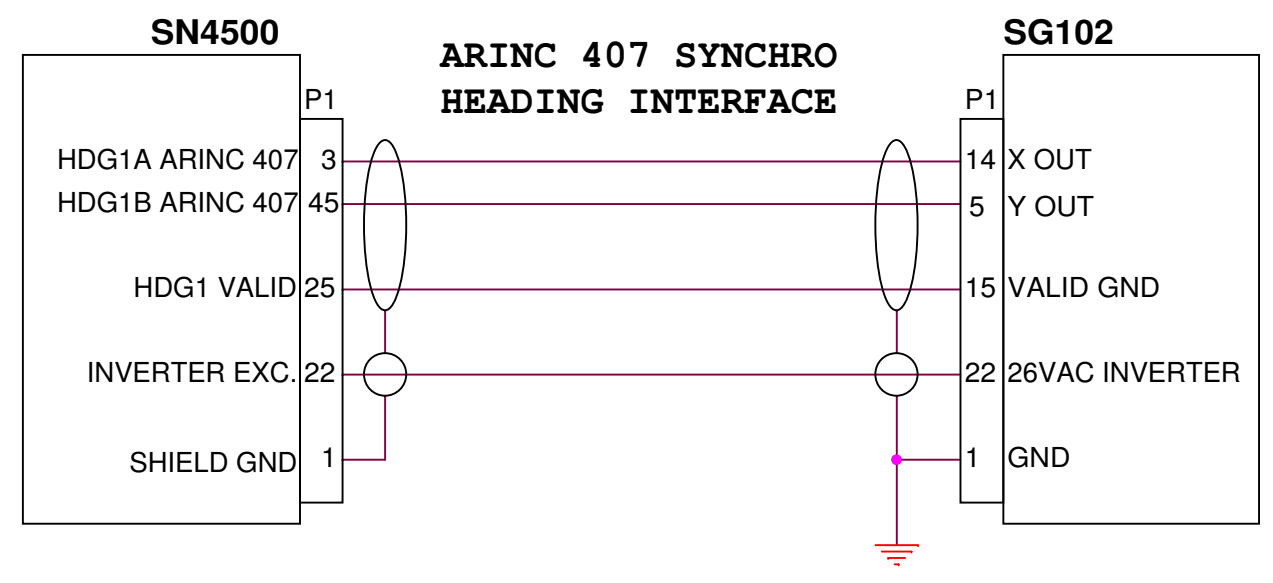
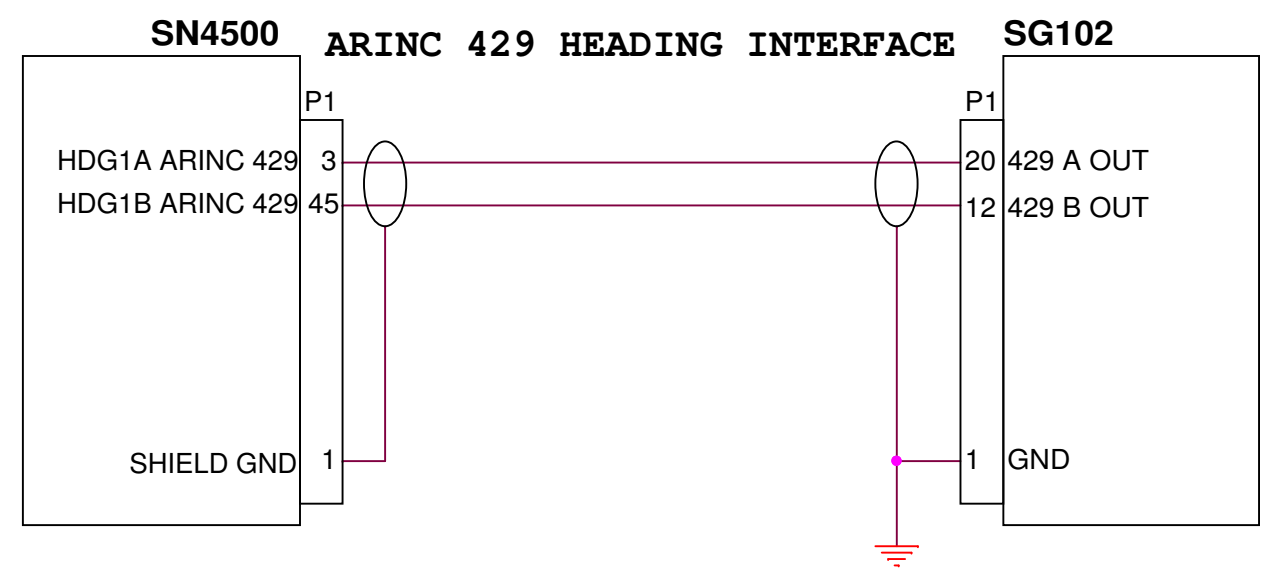

NOTES UNLESS OTHERWISE SPECIFIED

- 1. Unless otherwise noted, all signal wiring is 22 to 24 AWG.

<b>SANDEL</b> ®		Vista, Ca.
Category: SN4500 INSTALLATION DRAWING		
Title: SN4500 with SG102 ARINC 429 or 407 Interface		
Size: B	Document Number: <b>82009-10</b>	Rev: <b>B</b>
Create: Monday, December 10, 2007   Mod: Friday, February 10, 2012		Sheet 40

DATE	REV	COMMENTS
16-NOV-08	A	INITIAL RELEASE AR 1033

COMPUTER CONTROLLED DRAWING  
DO NOT REVISE MANUALLY

### ARINC 429/419 TACAN

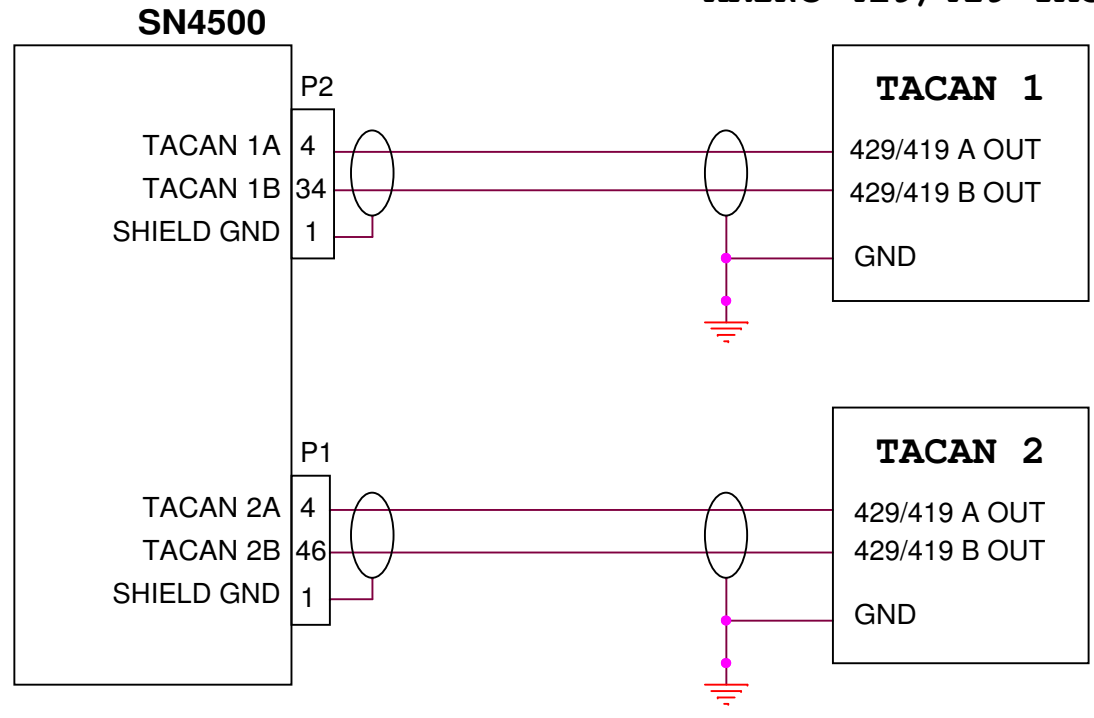

### ARINC 407 TACAN

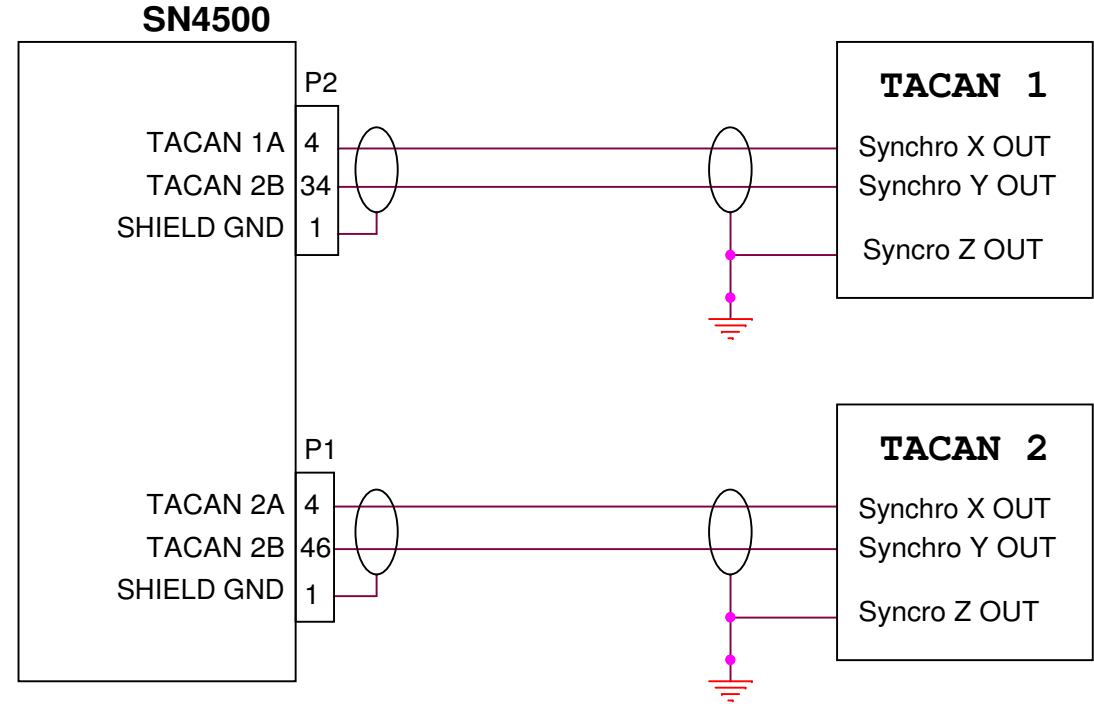

#### Notes

1. For distance and range rate when using Arinc 407 TACAN, use appropriate SN4500 DME interface on associated channel.

<b>SANDEL</b> <sup>®</sup>		Vista, Ca.
Category	SN4500 INSTALLATION DRAWING	
Title	SN4500 with TACAN	
Size B	Document Number <b>82009-10</b>	Rev <b>A</b>
Create: Sunday, November 16, 2008   Mod:		Sheet 41

DATE	REV	COMMENTS
12-SEP-08	A	INITIAL RELEASE AR 1033

COMPUTER CONTROLLED DRAWING  
DO NOT REVISE MANUALLY

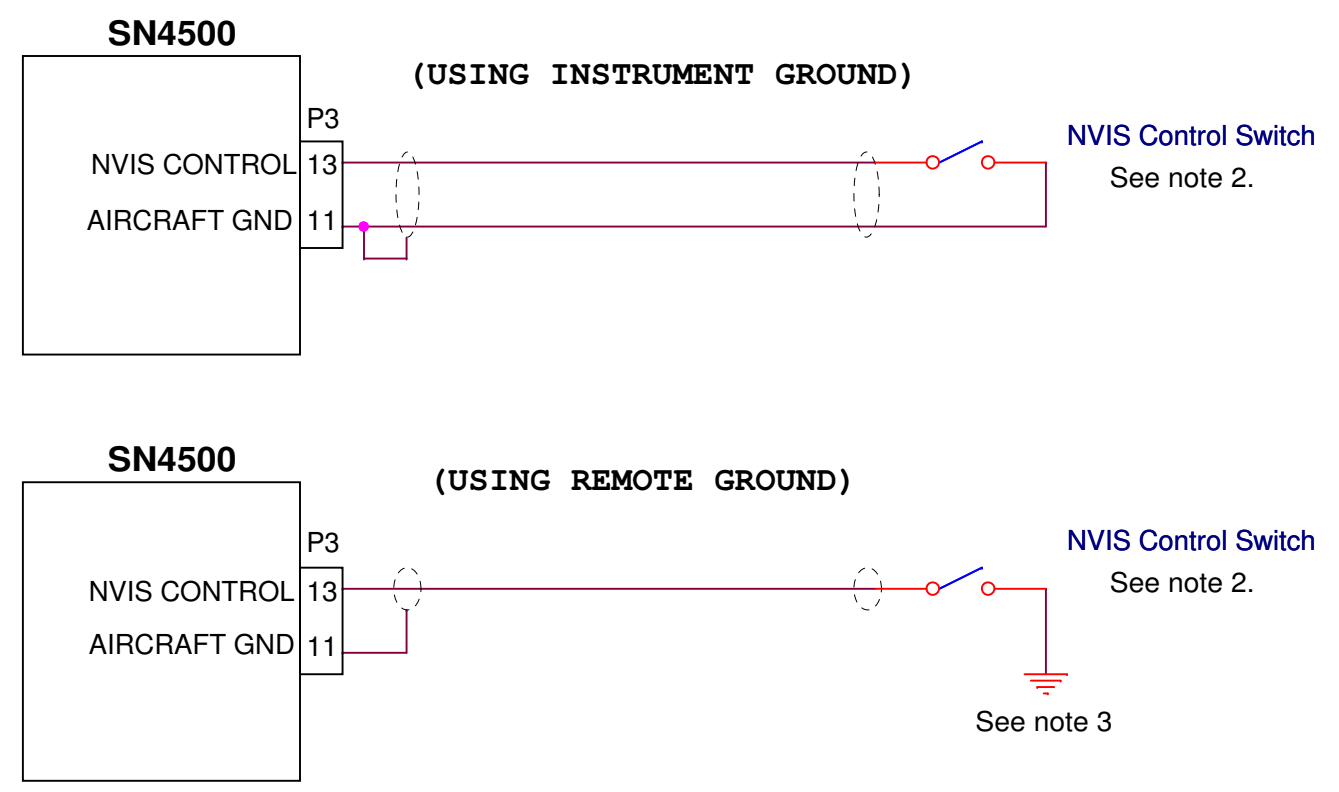

**Notes:**

1. Use 24 AWG stranded shielded 1 or 2 conductor wire as required.
2. TYCO P/N TT13A9T1/404 toggle switch or equivalent. A push-on/push-off pushbutton switch may be used. Annunciator not required.
3. Use closest available airframe ground.
4. In the event of a broken wire fault the SN4500 will default to daylight (non NVIS) mode.

<b>SANDEL</b> ®		Vista, Ca.
Category	SN4500 INSTALLATION DRAWING	
Title	NVIS CONTROL	
Size B	Document Number	Rev
	<b>82009-10</b>	<b>A</b>
Create: Friday, September 12, 2008	Mod:	Sheet 42

DATE	REV	COMMENTS
12-JAN-09	A	INITIAL RELEASE AR1048
11-FEB-08	A1	CORRECTED INITIAL RELEASE DATE AND PIN OUT AR1048
10-FEB-12	B	P3 PINS 6/13 WAS 6 UPDATED NOTE 8 A/R 1220

COMPUTER CONTROLLED DRAWING  
DO NOT REVISE MANUALLY

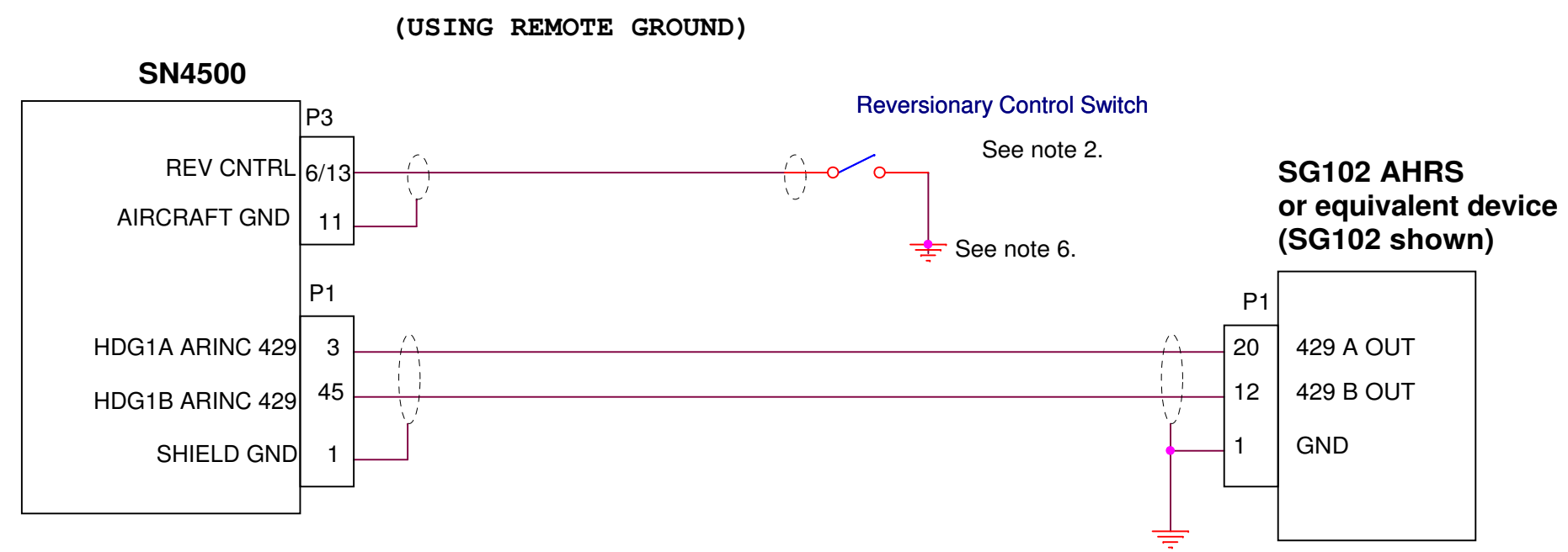
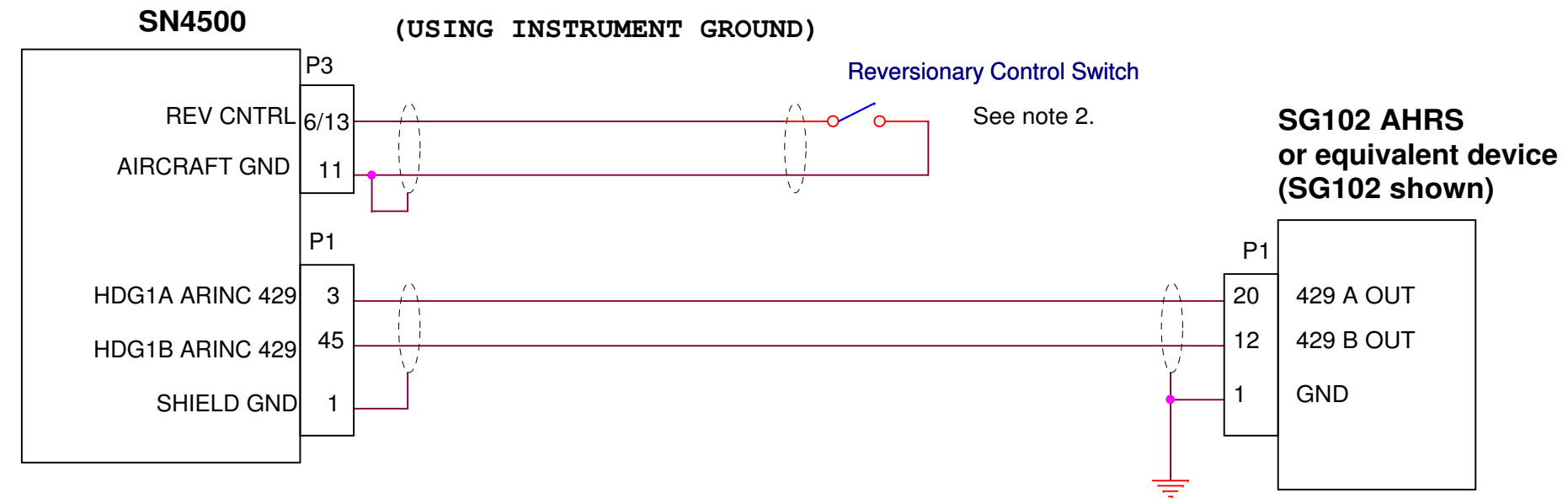

**Notes:**

1. Use 24 AWG stranded shielded 1 or 2 conductor wire as required.
2. TYCO P/N TT13A9T1/404 toggle switch or equivalent. A push-on/push-off pushbutton switch may be used. Annunciator not required.
3. Placard the switch "REV".
4. Locate switch and placard nearest position available to SN4500.
5. Assure adequate illuminatin of switch and placard for night operations under normal conditions.
6. Use closest available airframe ground.
7. In the event of a broken wire fault the SN4500 will default to normal display (non-reversionary) mode.
8. Standard configuration is to use P3-6 for REV CNTRL. If P3-6 is needed for Analog DME Valid (see section 2.5.3 page 2-12), use P3-13. NVIS/REV ATT/DME Analog Valid may not all be used simultaneously.

<b>SANDEL</b> ®		Vista, Ca.
Category	SN4500 INSTALLATION DRAWING	
Title	REVERSIONARY ATTITUDE DISPLAY OPTION	
Size B	Document Number	Rev B
	<b>82009-10</b>	
Create:	Mod:Friday, February 10, 2012	Sheet 43

DATE	REV	COMMENTS
07-MAR-22	A	INITIAL RELEASE AR 5047

COMPUTER CONTROLLED DRAWING  
DO NOT REVISE MANUALLY

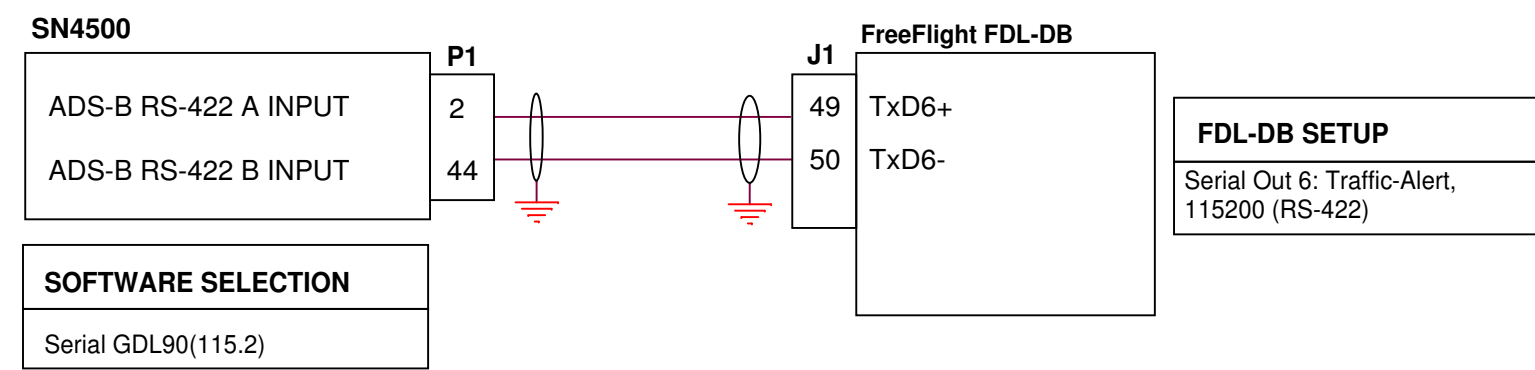
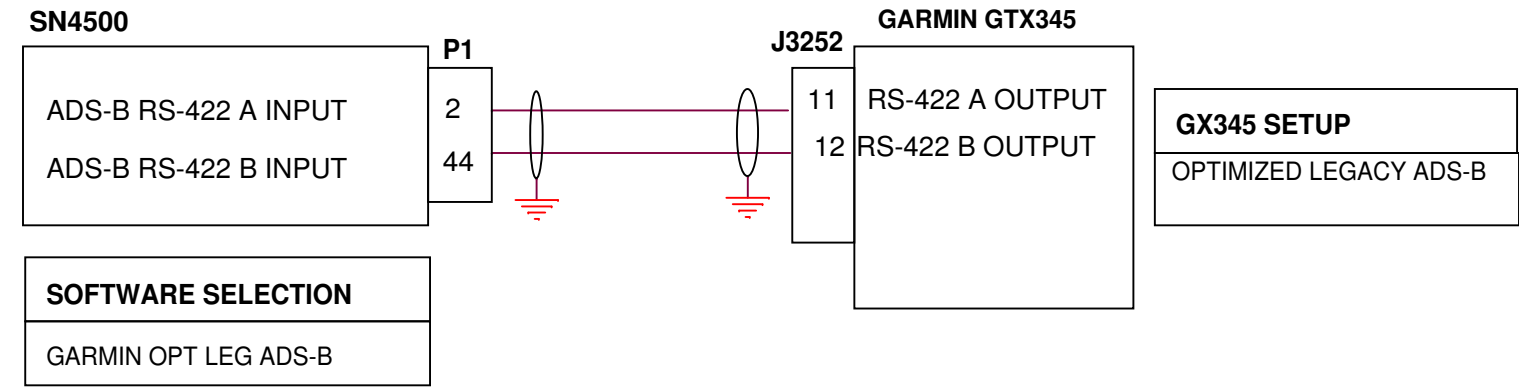

- NOTES:**
1. SEE MANUFACTURER'S INSTALLATION MANUALS FOR COMPLETE WIRIING INTERFACE.
  2. TRAFFIC INTERFACE REQUIRES PURCHASE OF KEY CODE.

**SANDEL**® Vista, Ca.

Category: SN4500 INSTALLATION DRAWING

Title: ADS-B IN TRAFFIC

Size B | Document Number: **82009-10** | Rev **A**

Create: | Mod: | Sheet 44